

智能阀门定位器

IP6500 系列用户手册

Intelligent Valve Positioner

IP6500 Series User's Manual



目录

1. 概述.....	1
2. 一键自动初始化.....	1
3. 选型及订货数据.....	2
4. 主要技术指标.....	3
5. 接口说明.....	4
6. 机械尺寸.....	5
6.1. 外形尺寸.....	5
6.2. 安装支架尺寸.....	6
6.3. 直行程反馈杆尺寸.....	10
6.3.1. 反馈杆 A（带传动销）.....	10
6.3.2. 反馈杆 B（不带传动销）.....	10
6.4. 分体式传感器尺寸.....	11
6.5. 远传型传感器尺寸.....	12
7. 安装.....	13
7.1. 直行程（常规型或远传型）.....	13
7.1.1. 常规管路连接安装.....	13
7.1.2. 无管路连接安装.....	25
7.2. 角行程（常规型或远传型）.....	26
7.3. 分体式.....	33
8. 操作.....	38
8.1. 界面描述.....	38
8.2. 主界面显示和操作.....	39
8.3. 菜单和功能.....	41
8.3.1. 菜单显示和操作.....	41
8.3.2. 功能描述和操作.....	41
8.3.2.1. TYPE.....	41
8.3.2.2. INITA.....	41
8.3.2.3. INITM.....	42
8.3.2.4. SDIR.....	42
8.3.2.5. CHAR.....	43
8.3.2.6. FREE.....	44

8.3.2.7.	DB	45
8.3.2.8.	LIM	45
8.3.2.9.	YDIR	46
8.3.2.10.	CUT.....	46
8.3.2.11.	POS	47
8.3.2.12.	SAFE.....	49
8.3.2.13.	STIM	49
8.3.2.14.	SPOS	49
8.3.2.15.	FACT.....	49
8.3.2.16.	SADDR	49
8.3.2.17.	WP.....	50
8.3.2.18.	ACT.....	50
8.3.2.19.	REF	50
8.3.2.20.	REC	50
8.3.3.	初始化过程错误提示.....	51
8.3.4.	菜单选项或功能无法访问提示.....	52
8.3.5.	菜单功能选项汇总说明.....	52
8.4.	PROFIBUS PA 功能和操作.....	53
8.4.1.	从站地址设置.....	53
8.4.2.	周期性数据传输.....	53
8.4.2.1.	组态.....	54
8.4.2.2.	数据定义.....	54
8.4.2.3.	数据组合.....	55
8.4.3.	非周期性数据传输.....	57
8.4.3.1.	SIMATIC PDM V6.0 操作步骤.....	57
8.4.3.2.	通过 SIMATIC PDM V6.0 设置从站地址.....	58
8.4.3.3.	通过 SIMATIC PDM V6.0 执行 FACT 和 CLR 功能.....	58
8.5.	流量调节.....	58
9.	故障检修.....	60
10.	保修条款.....	60

1. 概述

IP6500 系列智能阀门定位器和气动执行器配套使用。定位器通过 PROFIBUS PA 总线，接收来自控制系统的设定值，并采集位置传感器信号得到实际的阀位值。通过控制软件的计算处理，控制气动执行机构的进气和排气，从而驱动阀位到达设定点。

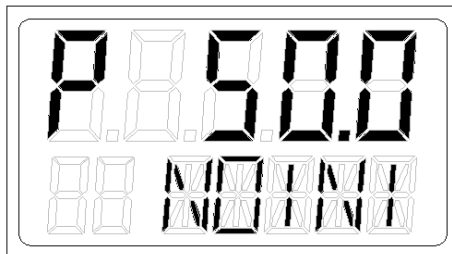

2. 一键自动初始化

1. 定位器安装前请仔细阅读第 7 章节的安装说明。按照所描述的安装要求来安装定位器。请注意一些安装要点。例如，安装前确认定位器或远传型传感器反馈轴的初始位置。安装过程中切勿将反馈轴转动 360°。对于常规型直行程定位器，确认定位器外壳上平面和阀的主轴成直角。在阀门行程范围内，定位器反馈杆转动角度符合安装要求。
2. 将定位器安装到阀门上后，接上气源和电气线缆。确保气源压力能完全打开阀门。通过 DP/PA 耦合器输出的电压信号给定位器上电。
3. 定位器上电后，系统在没完成初始化功能前处于未初始化状态。显示标志为 NOINI，界面第一行显示传感器百分比。如下图所示。



在此状态下，操作 $\blacktriangledown/\blacktriangle$ 键可打开或关闭阀门。将阀门全开和全闭，观察界面上显示的传感器百分比。对于非分体式，确保在整个阀门行程范围内，传感器百分比最小值 $\geq 5\%$ ，传感器百分比最大值 $\leq 95\%$ 。否则，需要重新调整安装位置使直行程反馈杆或角行程适配器在有效范围内动作。对于分体式，确保在阀门行程 5-25mm 范围内，传感器百分比最小值 $\geq 12\%$ ，传感器百分比最大值 $\leq 92\%$ ；在阀门行程 25-50mm 范围内，传感器百分比最小值 $\geq 2\%$ ，传感器百分比最大值 $\leq 97\%$ 。否则，需要调整传感器 D 值。另外，要求传感器最小最大百分比差值大于 16%（非分体式）或 8%（分体式）。

4. 定位器出厂前已设置好执行机构类型。用户只需一键执行自动初始化 (INITA) 功能来完成对阀门的匹配。在初始界面 (NOINI) 或手自动模式界面长按 ⏻ 键 3 秒左右开始运

行自动初始化。初始化完成后，LCD 上显示 FINSH，按  键退出。退出后，系统进入手动模式界面，再次按  键可切换到自动模式。自动初始化过程中由于某些原因，系统会在功能选项栏显示错误提示。并中断初始化。错误提示说明及处理方法详见 8.3.3 章节。

3. 选型及订货数据

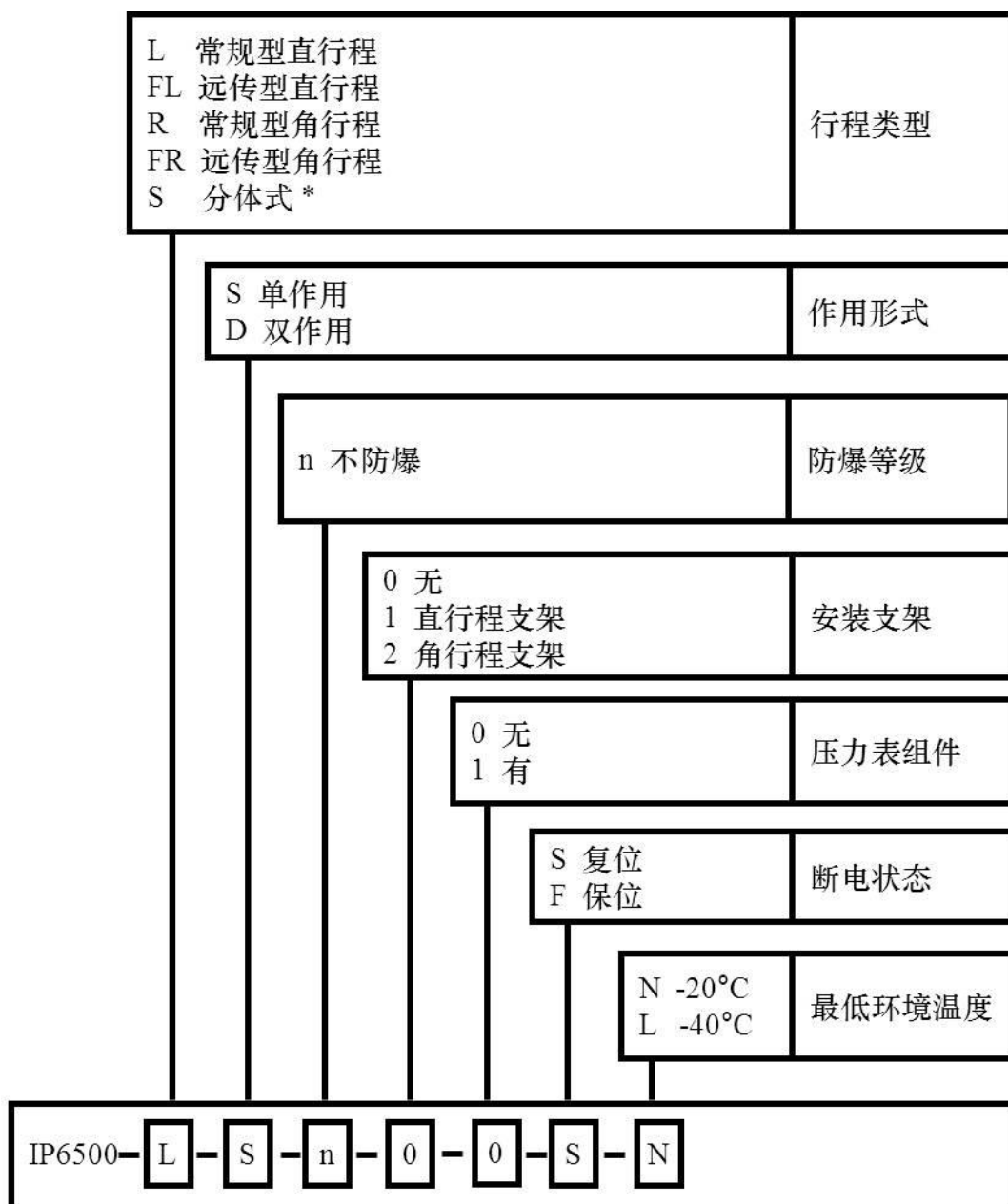

备注：

行程类型选项中，*标记选项 S(分体式)不支持最低环境温度选项 L (-40°C)。

4. 主要技术指标

外壳材质	铝合金
供电电源及信号传输	DP/PA 耦合器
本安供电电压	17.5V DC
工作电压范围	9~32V DC
环境温度	非防爆常规版本: -20°C ~ +80°C 非防爆低温版本: -40°C ~ +80°C 设备显示屏在-20°C 以下会显示迟钝或不显示。
气源要求	符合 ISO 8573-1 <ul style="list-style-type: none"> ● 固体颗粒大小和密度 3 级 ● 露点 3 级 ● 含油量 3 级
抗振动性	0.15mm, 10Hz-60Hz, 20 次循环/轴 20m/s ² , 60Hz-500Hz, 20 次循环/轴 整个控制阀连续运行时的推荐范围≤20 m/s ² , 无谐振峰值
气源压力	0.14-0.7MPa
流量	<ul style="list-style-type: none"> ● 进气 2 bar 4.8 Nm³/h 4 bar 8.0 Nm³/h 6 bar 11.2 Nm³/h ● 排气(复位) 2 bar 5.9 Nm³/h 4 bar 9.8 Nm³/h 6 bar 13.7 Nm³/h ● 排气(保位) 2 bar 6.6 Nm³/h 4 bar 11.1 Nm³/h 6 bar 15.6 Nm³/h
稳态耗气量	≤0.4 L/min
基本误差	≤1.0%
回差	≤1.0%
电气接口	1/2NPT(默认)或 M20x1.5, 其他螺纹规格请与销售沟通

气动接口	1/4NPT(默认)或 G1/4，其他螺纹规格请与销售沟通
重量	2.0 kg
防护等级	IP67

5. 接口说明



图1. 接口说明

电气接口	描述
IN+	总线信号 +
IN-	总线信号 -

气动接口	描述
SUP	气源进入
OUT1	先导气口 1
OUT2	先导气口 2，双作用时使用

备注：分体式 OUT1 和 OUT2 堵住不用。

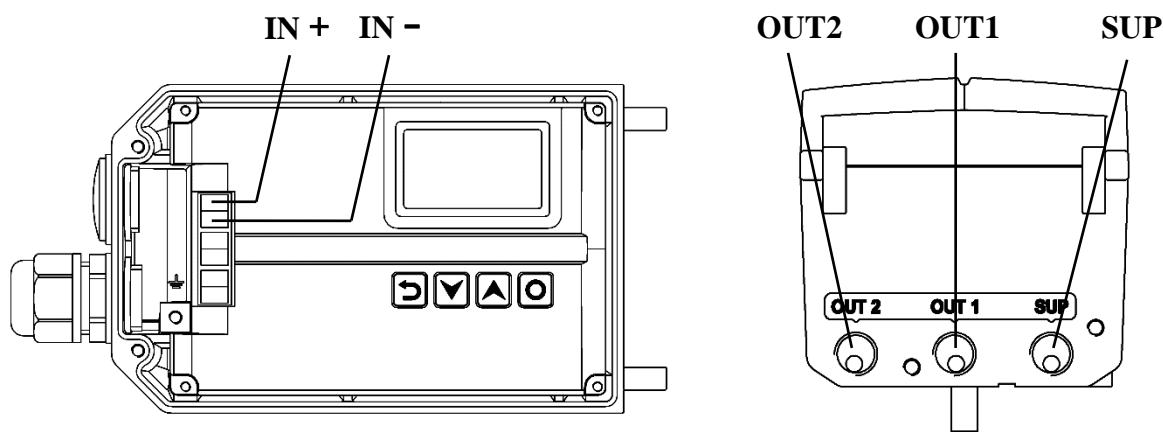
注意：

- 强烈推荐使用全屏蔽，多对双绞线电缆。并将线缆屏蔽层一端连接设备壳体内 — 处的螺钉，另一端连接大地。从而使设备有效接地，防止电磁干扰。
- 电气线缆铺设要远离强磁场环境。
- 请在设备断电情况下连接或拆卸电气线缆。
- 如果在本安防爆环境下使用设备，必须使用符合设备本安防爆等级的电气线缆。

6. 机械尺寸

6.1. 外形尺寸



图2. 外形尺寸

6.2. 安装支架尺寸



图3. 常规型直行程安装支架

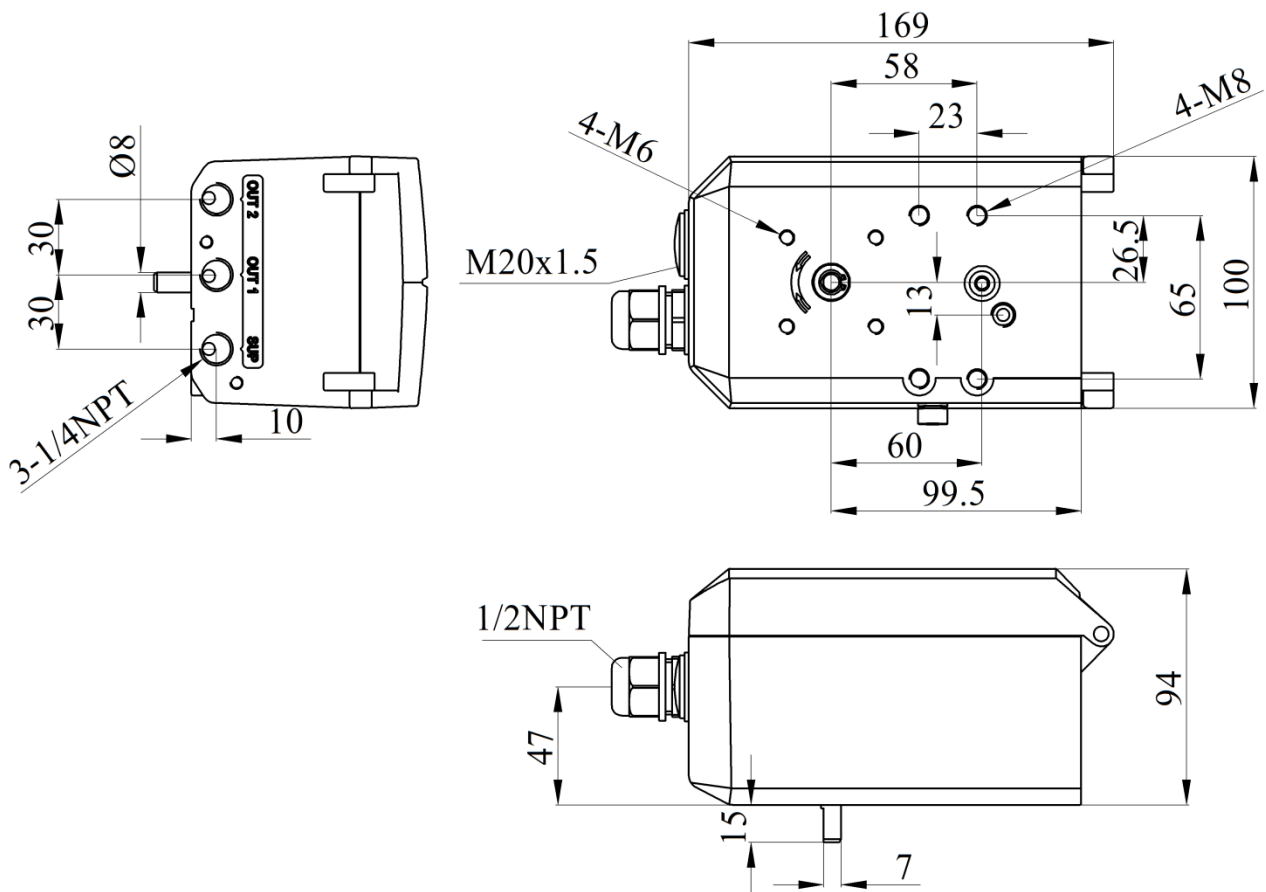

图4. 远传型直行程安装支架

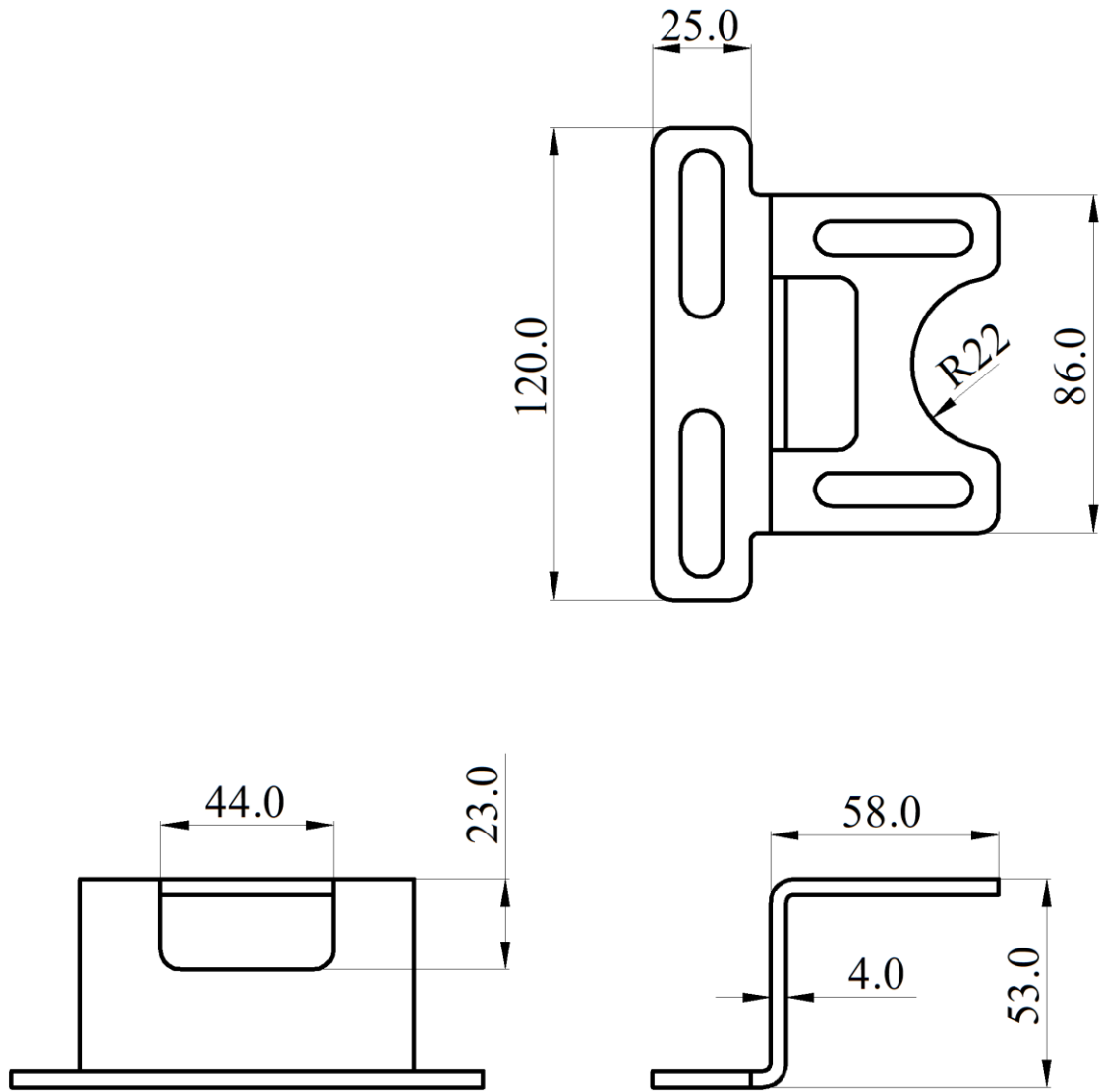

图5. 角行程安装支架 A 型

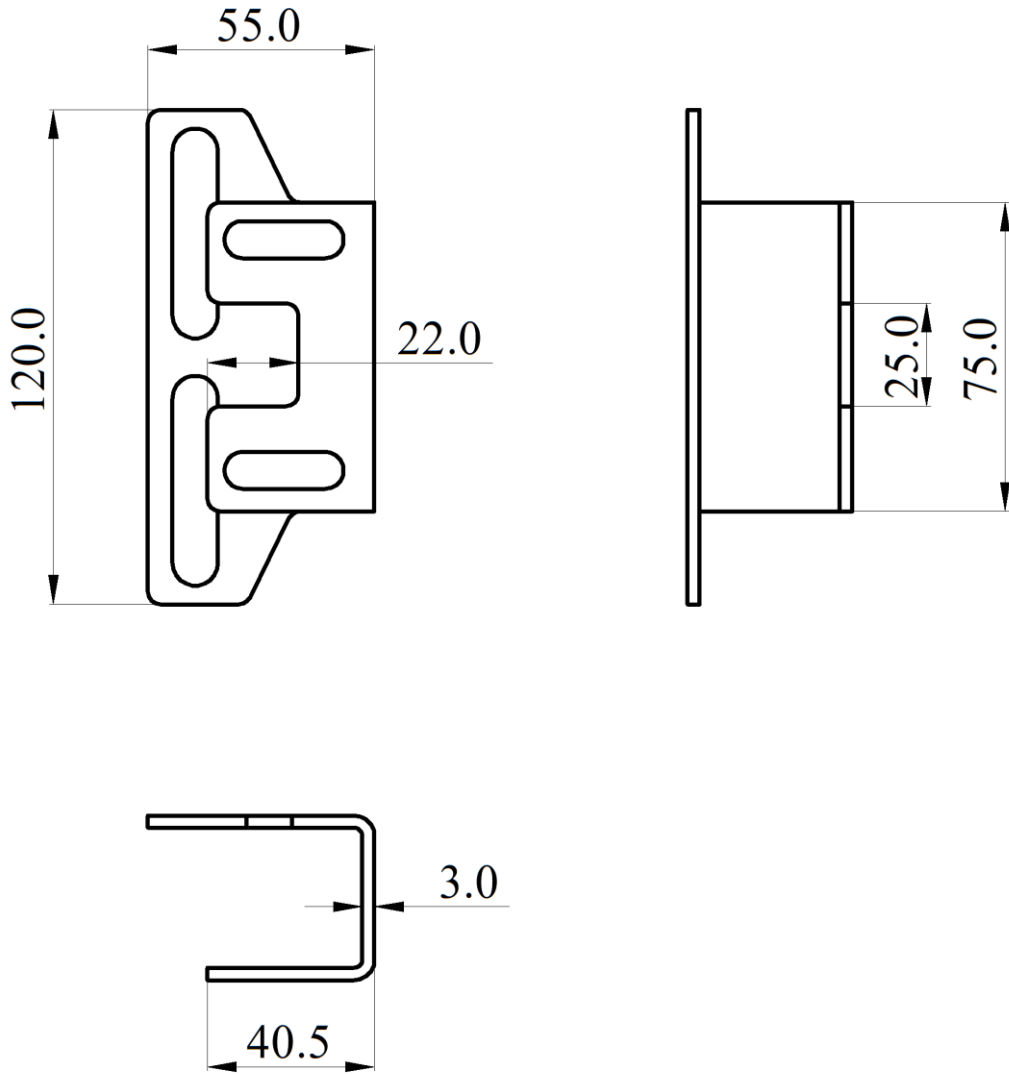

图6. 角行程安装支架 B 型

6.3. 直行程反馈杆尺寸

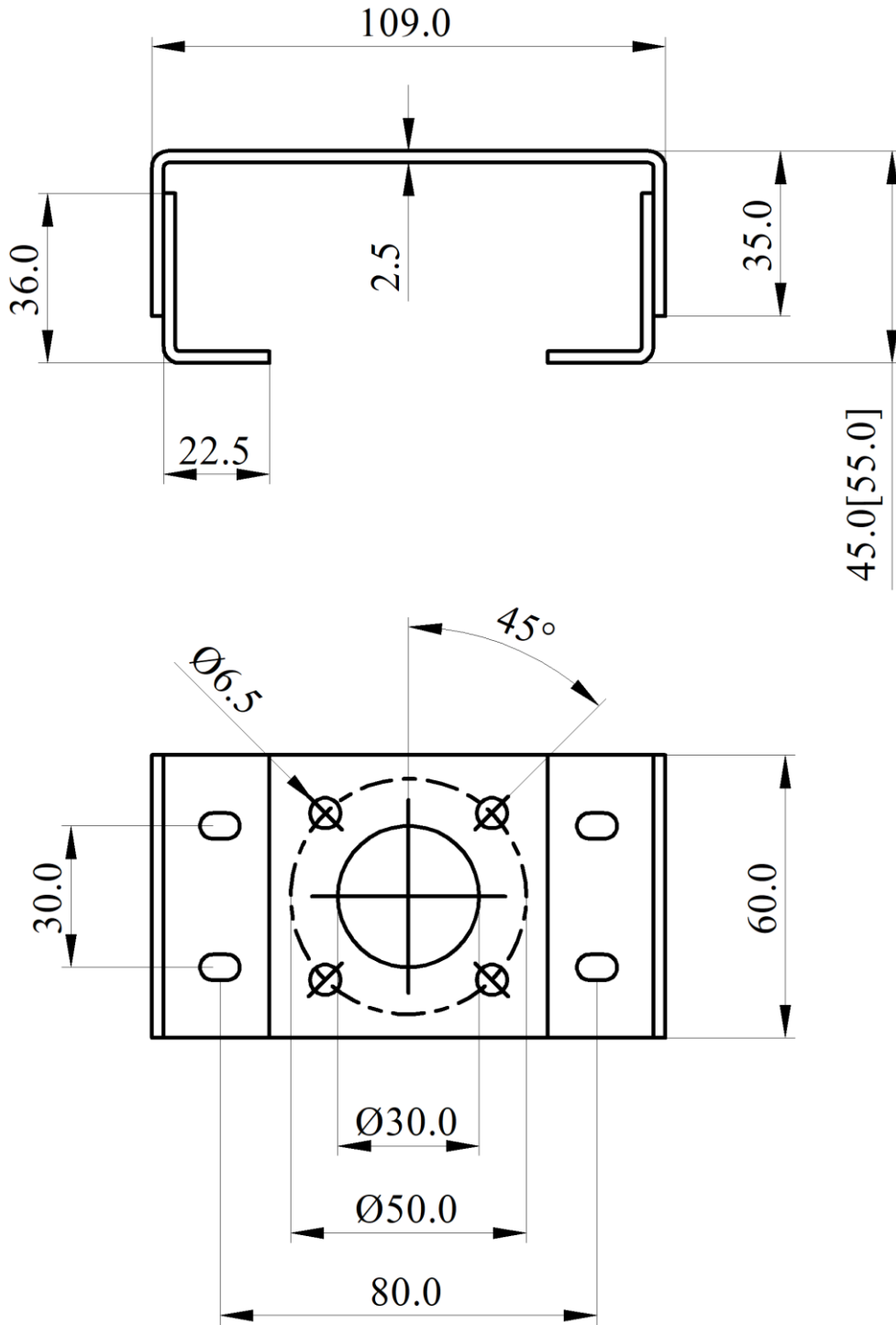
6.3.1. 反馈杆 A (带传动销)

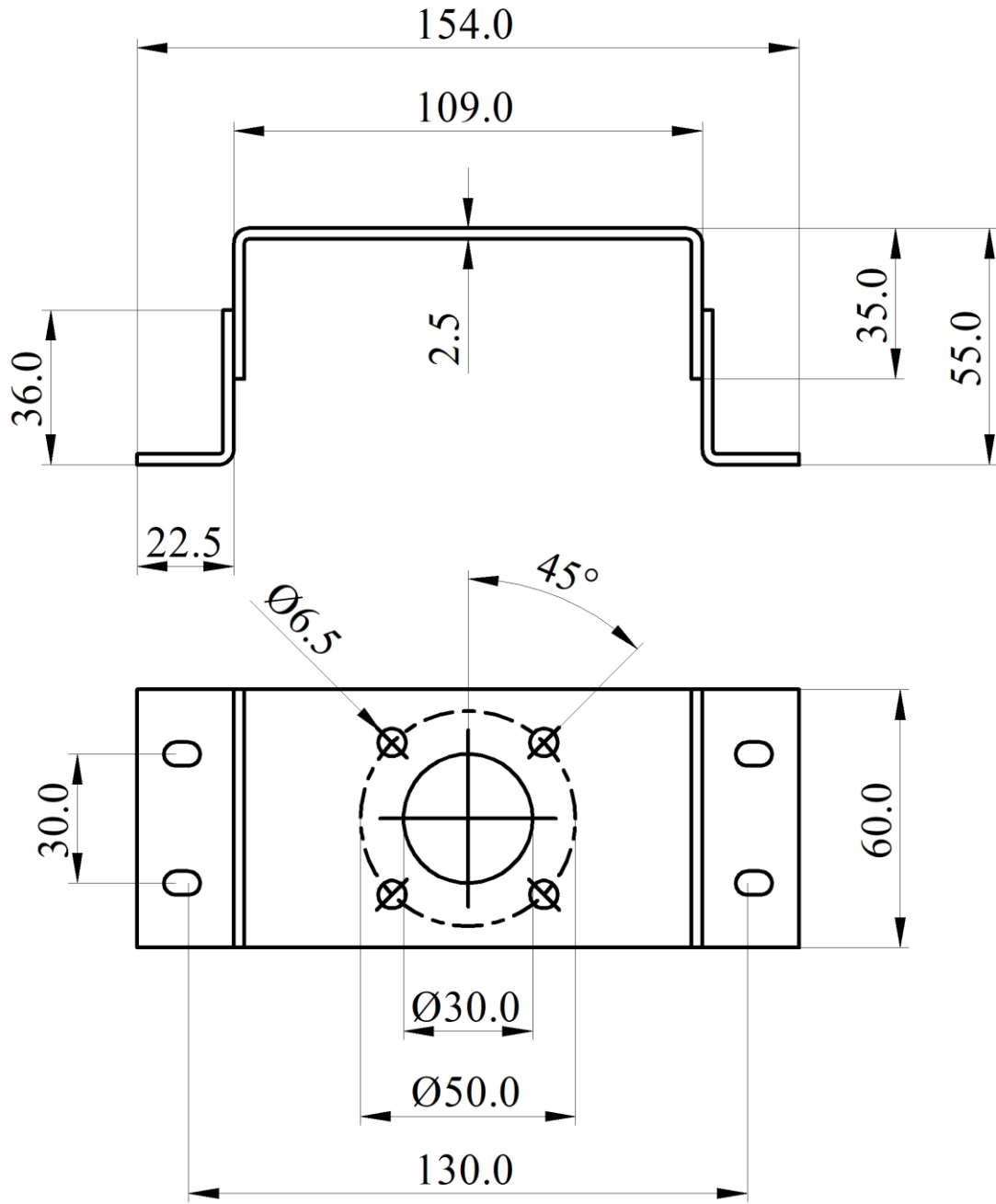

图7. 反馈杆 A 尺寸

6.3.2. 反馈杆 B (不带传动销)

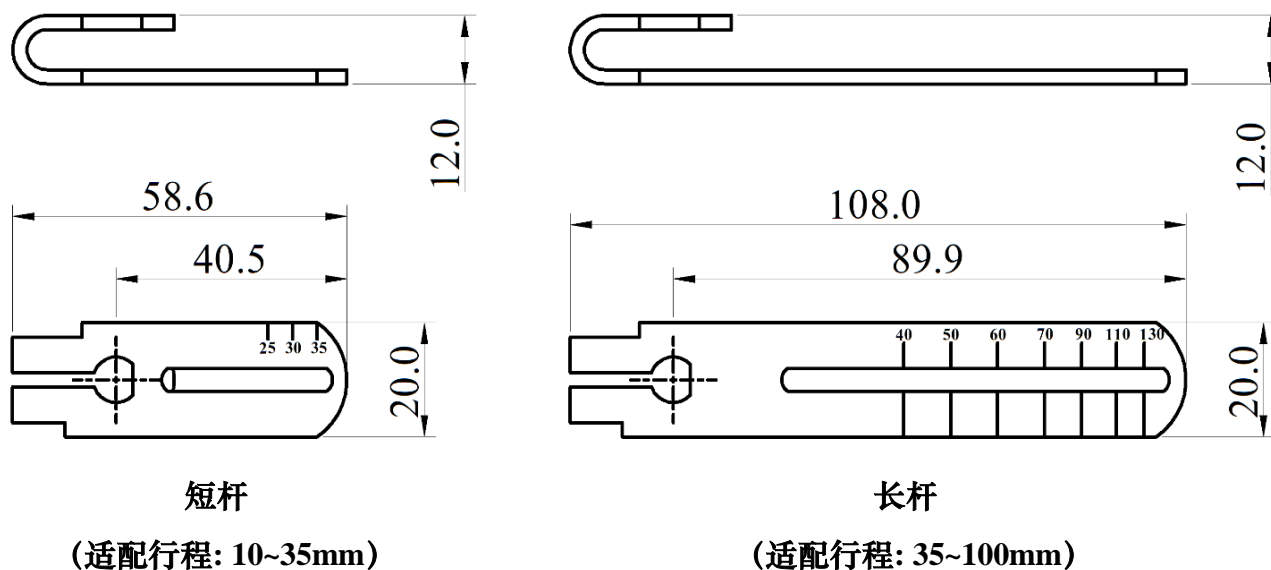

图8. 反馈杆 B 尺寸

6.4. 分体式传感器尺寸

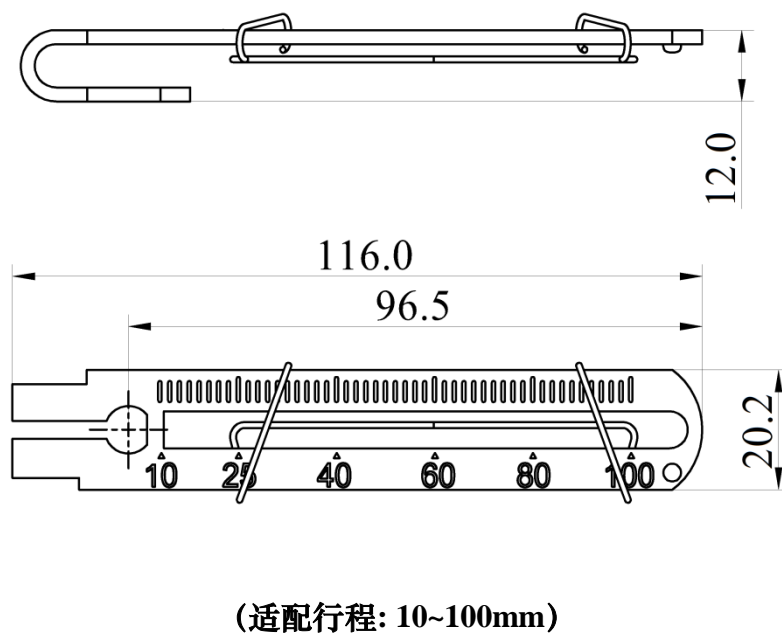

图9. 分体式传感器尺寸

6.5. 远传型传感器尺寸

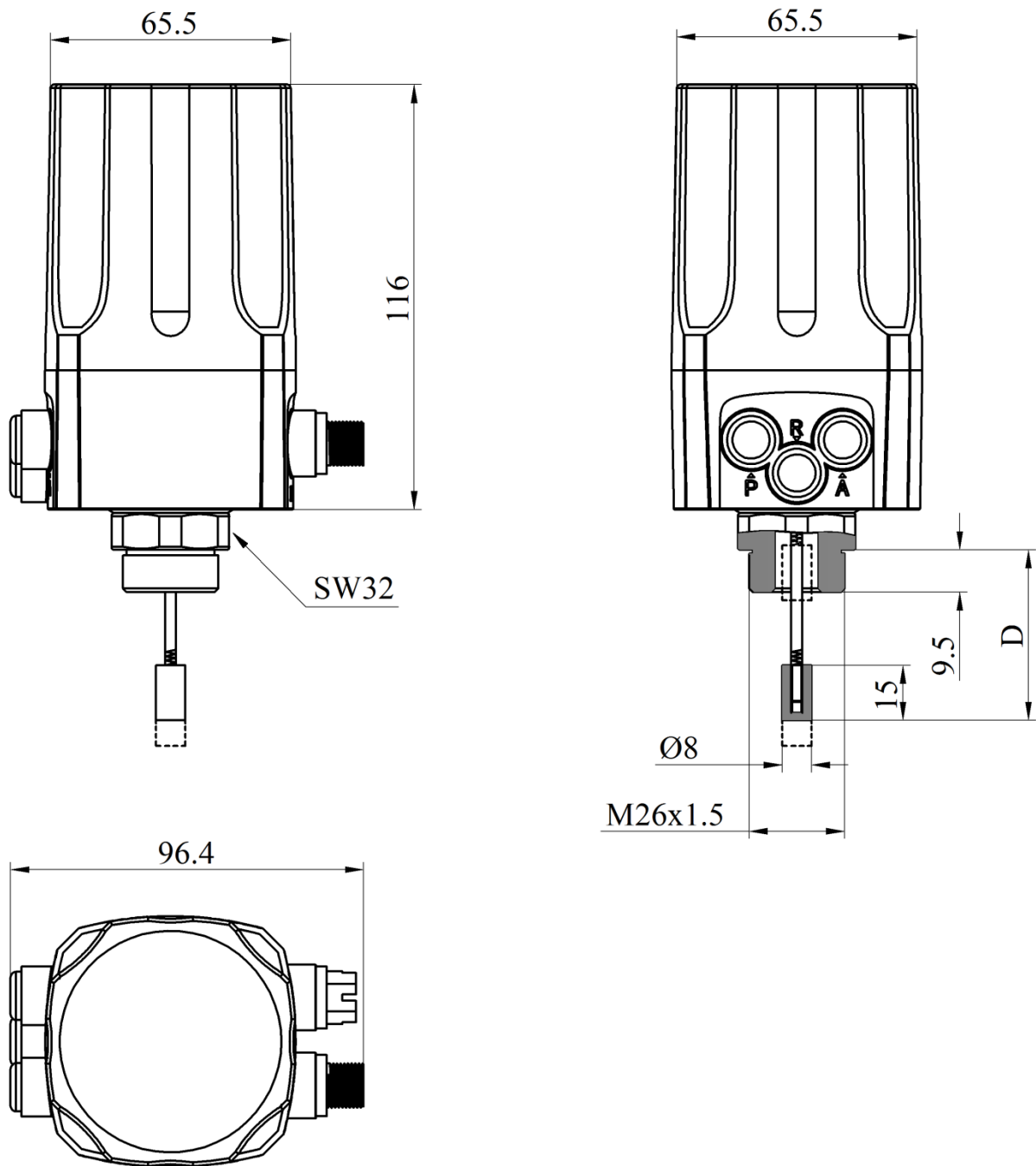

图10. 远传型传感器尺寸

7. 安装

7.1. 直行程（常规型或远传型）

直行程执行机构安装组件			
序号	名称	数量	注意
①	U 型杆	1	工作过程中使反馈杆发生旋转
②	夹板	1	在执行机构上安装 U 型杆
③	M6 内六角螺钉	2	M6×25
④	M6 弹簧垫圈	2	防止螺钉松动
⑤	反馈杆 A 或 B	1	安装在定位器主轴上
⑥	M6 内六角螺栓	1	M6×20, 搭配方形螺母
⑦	直行程安装支架	1	连接定位器与执行器
⑧	M8 六角头螺栓	2	M8×10
⑨	M8 弹簧垫圈	2	防止螺栓松动
⑩	M8 平垫圈	2	保护接触平面
⑪	匹配反馈杆 B 的传动销	1	安装在阀的主轴上

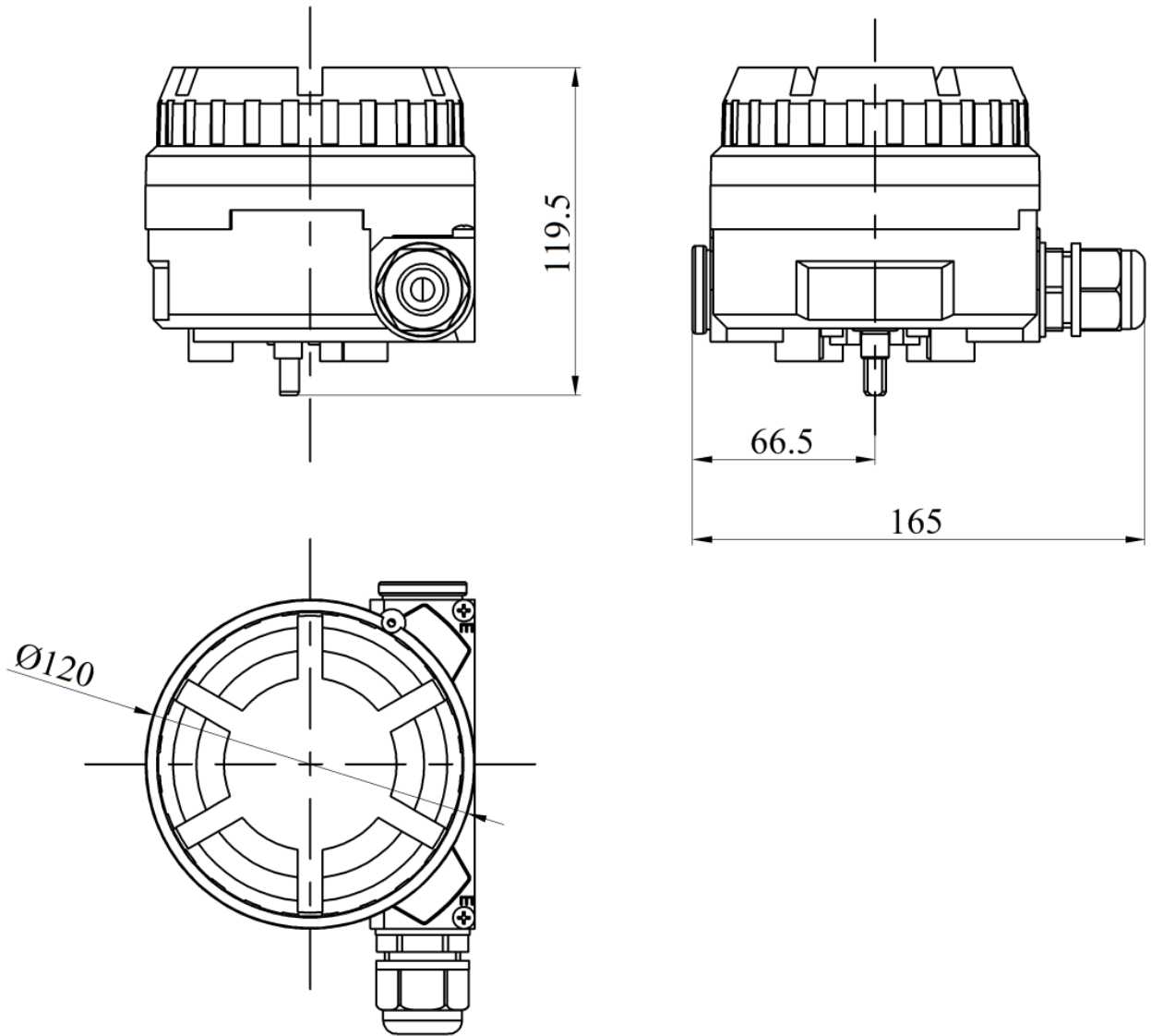
7.1.1. 常规管路连接安装

1. 确认定位器或远传型传感器反馈轴的初始位置。



图11. 反馈轴初始位置

转动反馈轴，将反馈轴上的指针指向图 11 所示箭头的方向。箭头的方向定义为初始

位置。给定位器上电，在初始界面 (NOINI) 观察传感器百分比值，确认数值在 40~60% 之间。如果不是，将反馈轴转动 360°，再次确认。确认之后，将定位器断电。

2. 把匹配反馈杆 A 的 U 型杆或匹配反馈杆 B 的传动销安装到执行器上。

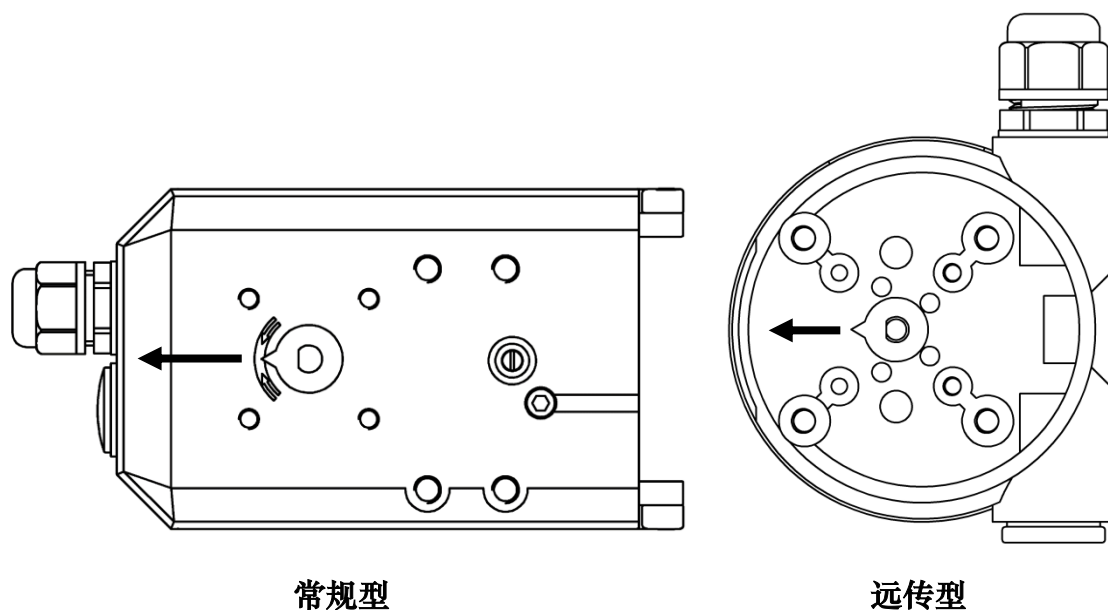

图12. U 型杆安装



图13. U 型杆安装方向

用内六角螺钉③和弹簧垫圈④把 U 型杆①和夹板②固定在执行器的中心轴上，使用内六角扳手拧紧螺钉。

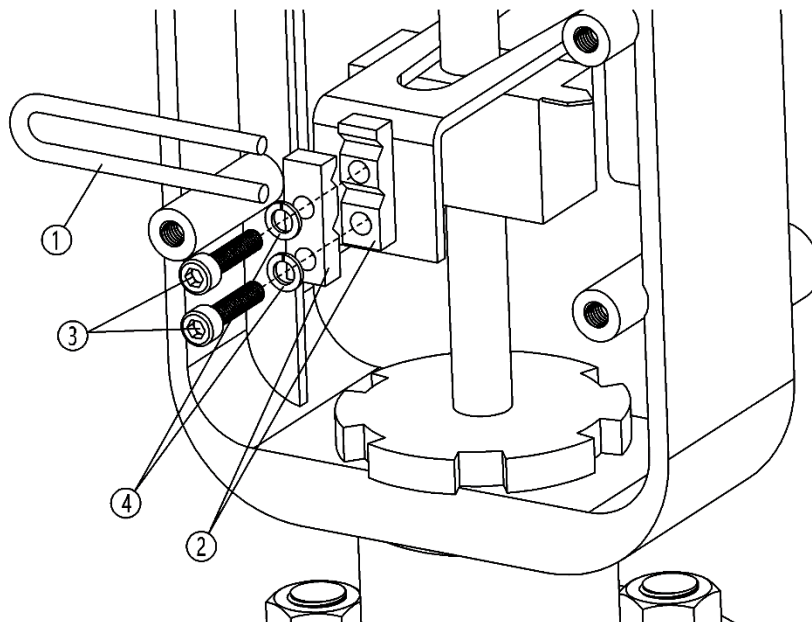

图14. 传动销安装

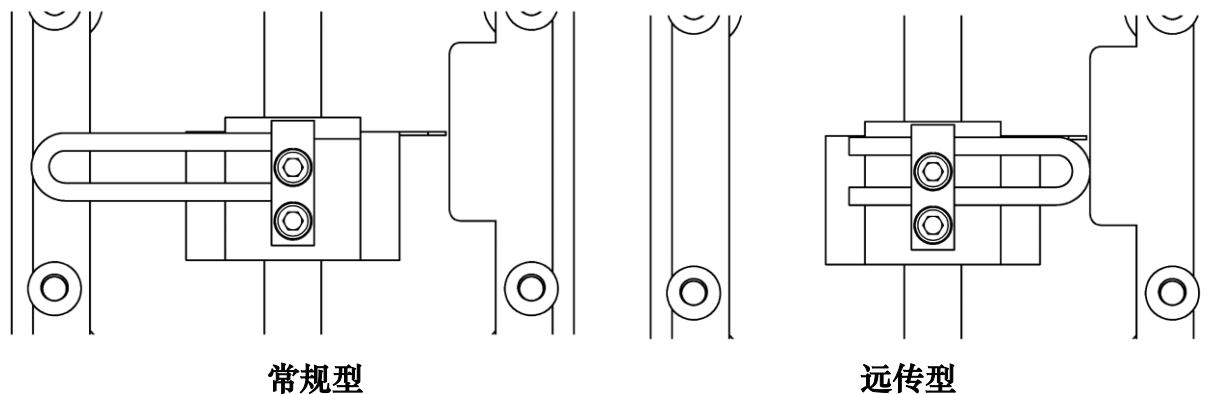
将传动销⑪安装到阀的主轴上。反馈杆 B 的插槽高度为 6.2 mm。因此用户如果未使用提供的传动销，需注意使用传动销的直径为 6 mm，传动销与阀的主轴上的螺纹大小须一致。

3. 安装匹配反馈杆 A 的传动销。

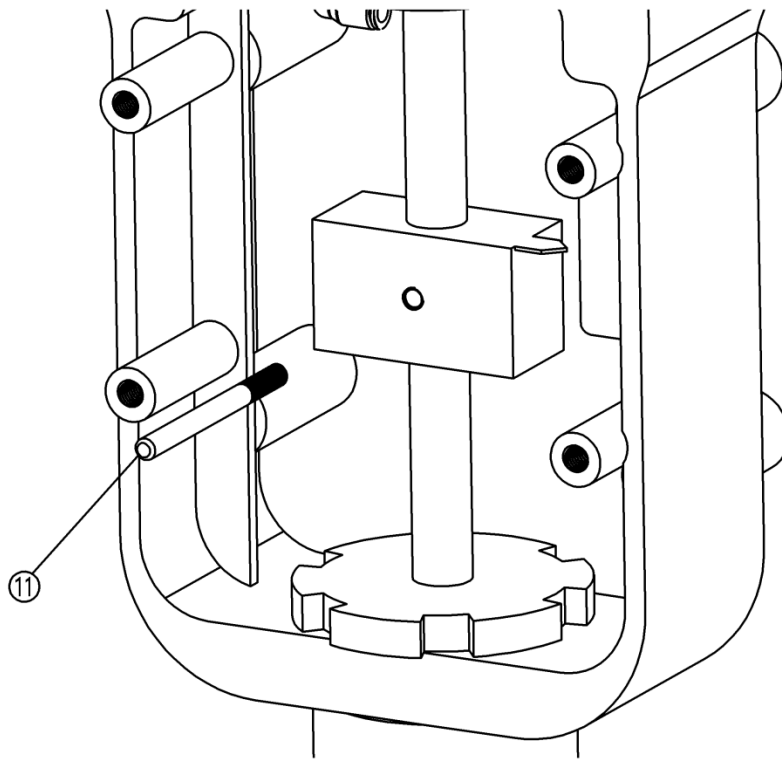

图15. 匹配反馈杆 A 的传动销安装

根据阀门实际行程选择上图对应的反馈杆。将传动销安装至反馈杆上的对应的行程刻度处。如果传动销不对应标尺刻度安装，当阀门动作时，可能会造成反馈杆损坏。比

如对于 100mm 行程的阀门，将传动销装在刻度 40 处，当阀门动作时，可能会使反馈杆受力变形。如果阀门行程不在反馈杆 A 的行程范围内，请咨询厂家。

4. 把反馈杆和直行程安装支架安装到定位器或远传型传感器上。

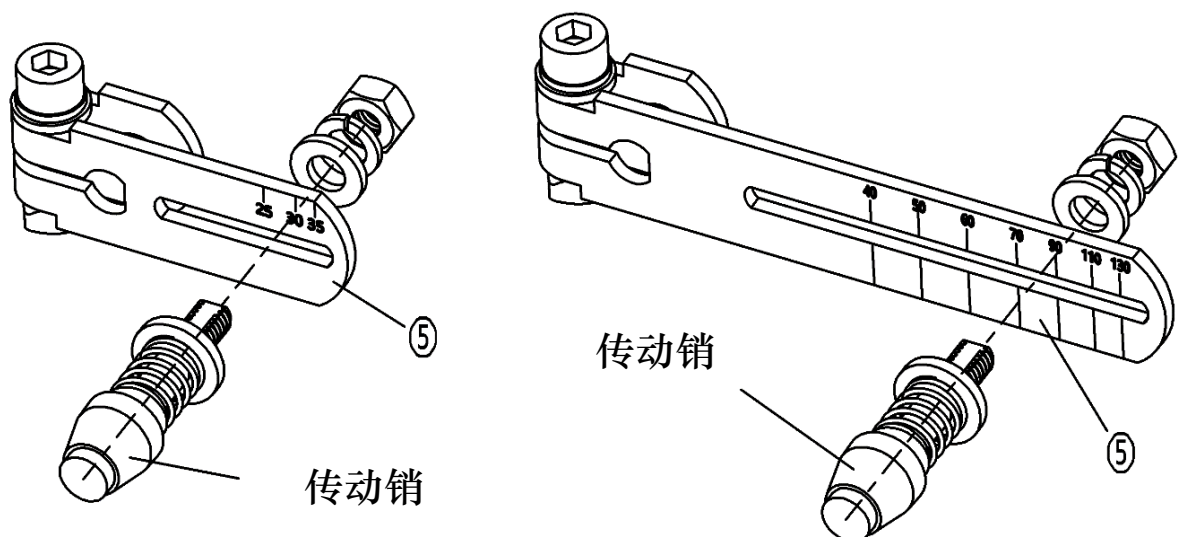

图16. 反馈杆 A 和安装支架安装（常规型）



图17. 反馈杆 A 和安装支架安装（远传型）

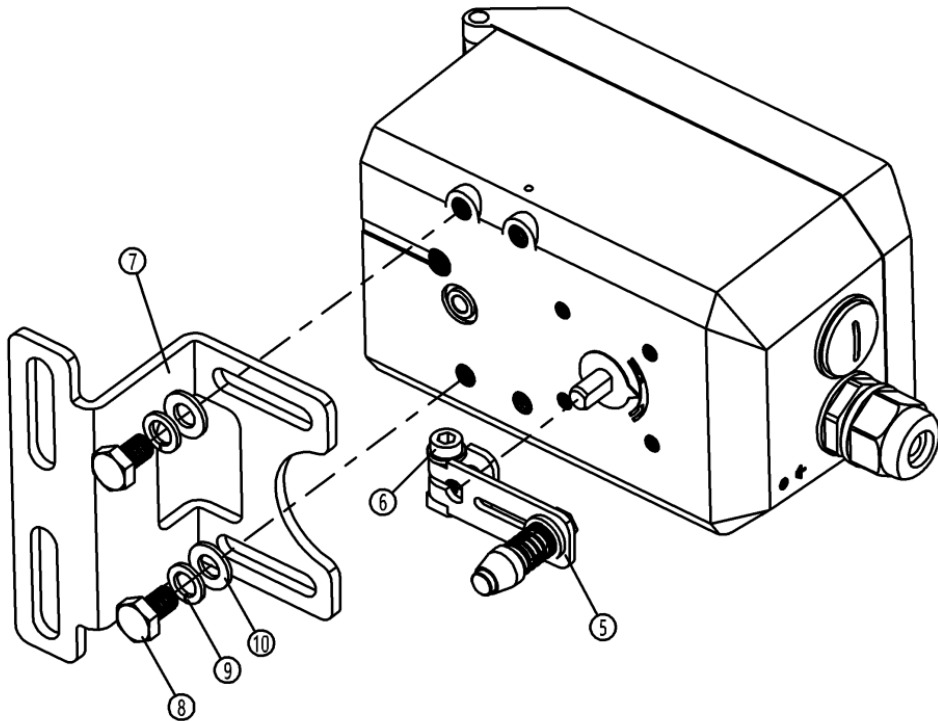

图18. 反馈杆 B 和安装支架安装 (常规型)

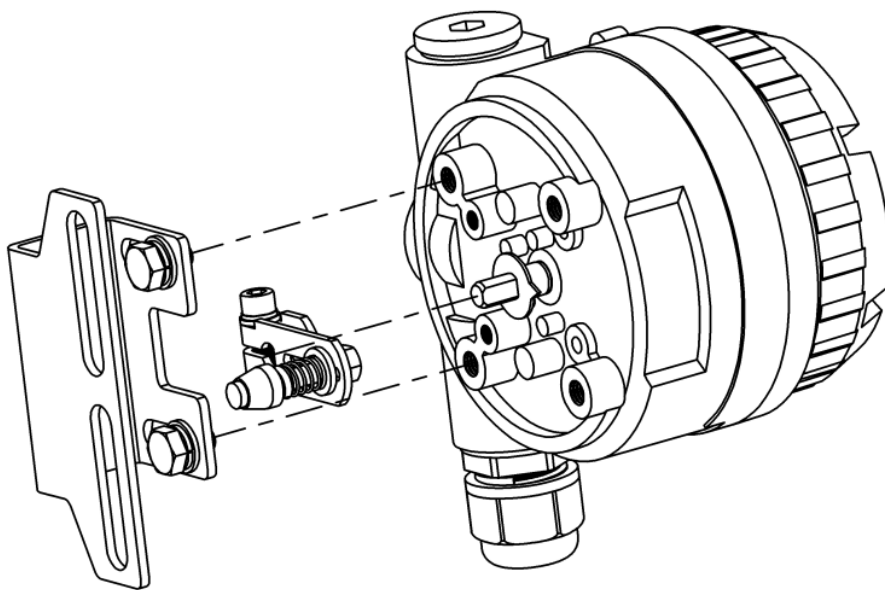

图19. 反馈杆 B 和安装支架安装 (远传型)

- 把反馈杆 A 或 B⑤连接到定位器或远传型传感器后部的反馈轴上。
- 观察箭头标记，检查反馈杆行程是否在可操作范围内。
- 使用内六角扳手拧紧内六角螺栓⑥。
- 用六角头螺栓⑧、弹簧垫圈⑨及平垫圈⑩把直行程安装支架⑦预紧在定位器或远传型传

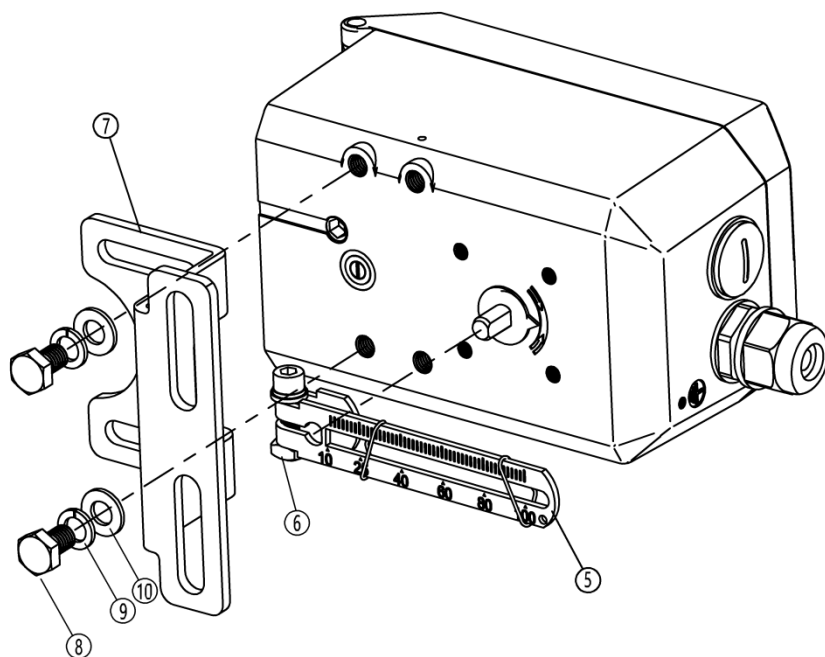
感器上。

5. 把直行程安装支架固定于执行器上。

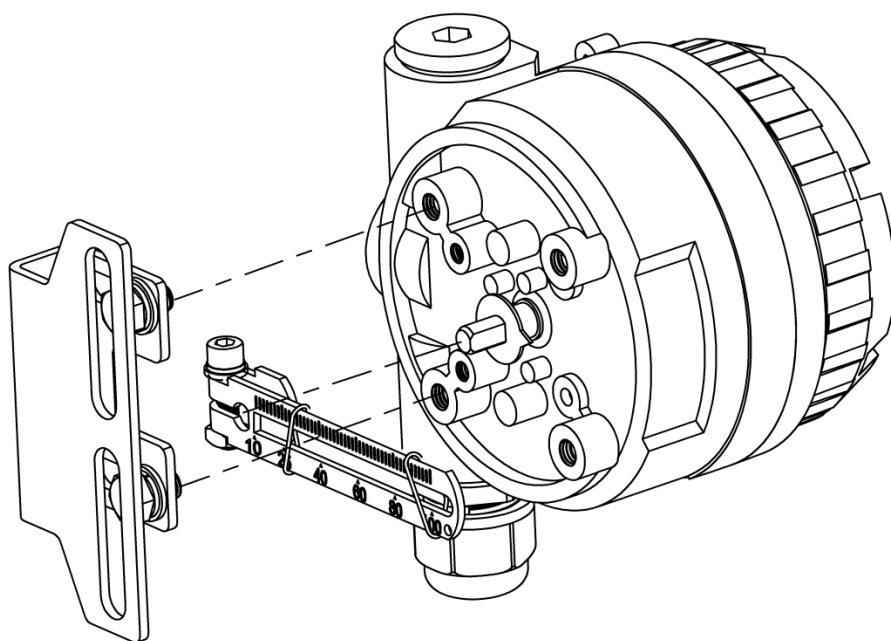

图20. 阀门行程中点



图21. 反馈杆 B 和传动销连接

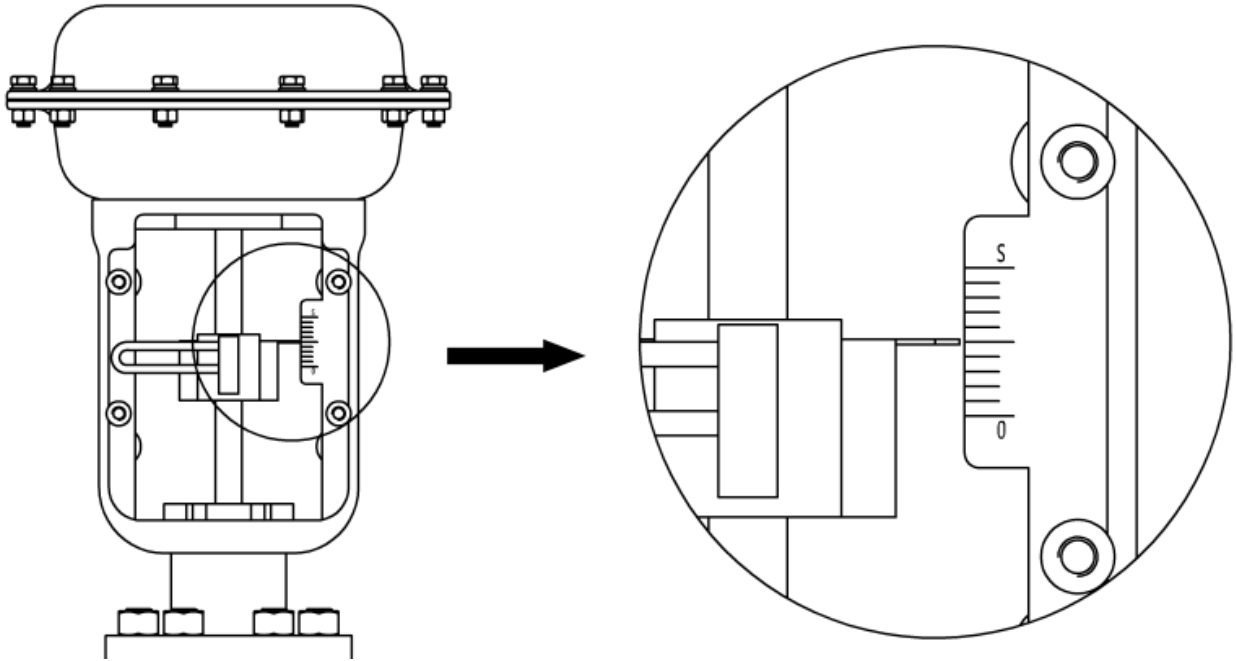

图22. 与执行器安装 (反馈杆 A)

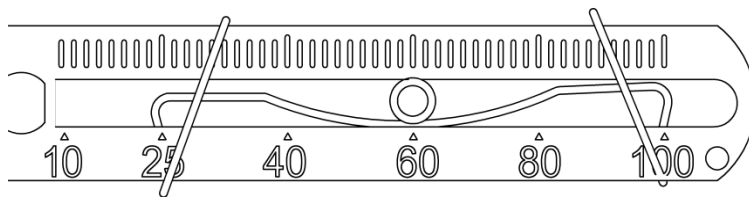

图23. 与执行器安装 (反馈杆 B)

- 给阀门气缸通气，依据阀门上的行程标尺将阀位调到行程中点，如图 20 所示。
- 对于反馈杆 A，使直行程安装支架⑦贴住执行器，反馈杆⑤的头部进入 U 型杆①。对于反馈杆 B，把传动销⑪插入到反馈杆 B 插槽内的固定弹簧上，如图 21 所示。调整位置，

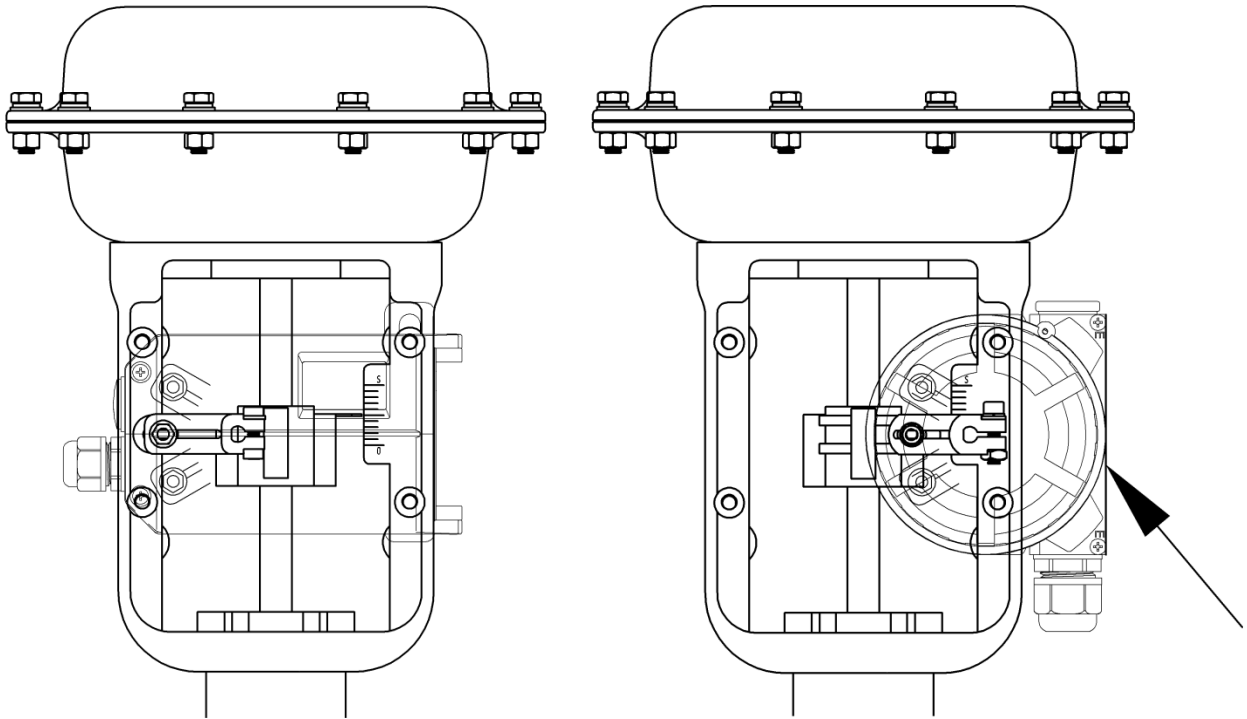
目测确认阀的主轴和反馈杆成直角。如无法成直角则按实际情况安装。

- 反馈杆全行程摆动角度建议在 40° ~ 90° 之间。可通过调整反馈杆传动销与定位器或远传型传感器转轴间的距离（角度转动半径）来改变摆动角度。
- 对于常规型直行程定位器，确保定位器外壳上平面和阀的主轴成直角。对于远传型直行程定位器，确保传感器壳体箭头（图 22 和图 23 右侧所示）所指平面与阀的主轴互相平行。否则会影响控制精度。最后用螺栓锁紧支架。

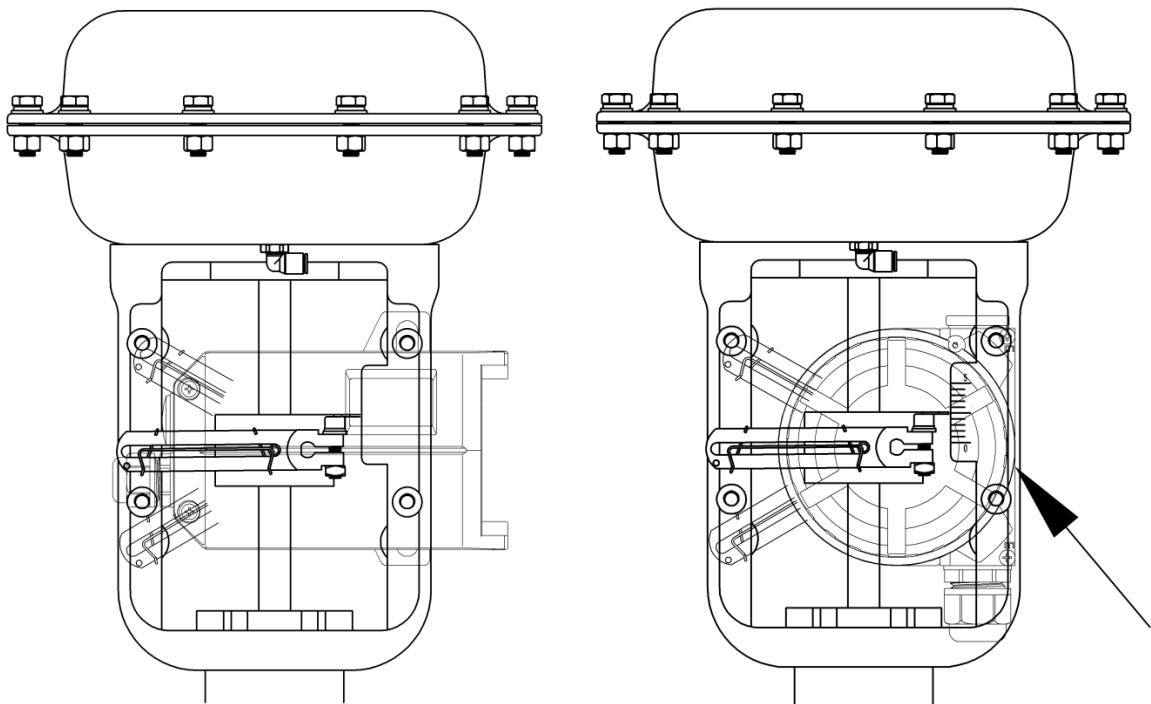
6. 整体示意图



图24. 常规型直行程（反馈杆 A）



图25. 远传型直行程（反馈杆 A）

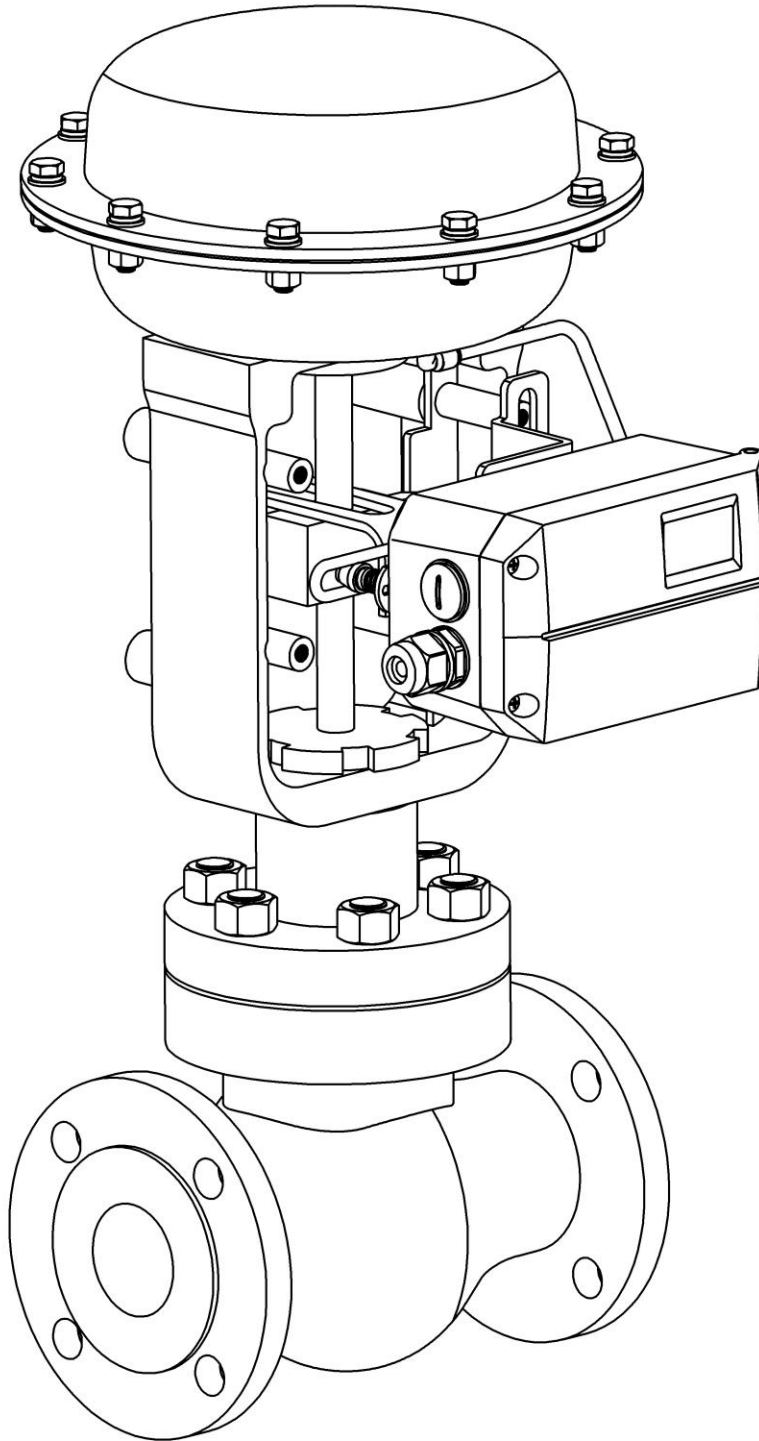

图26. 常规型直行程（反馈杆 B）

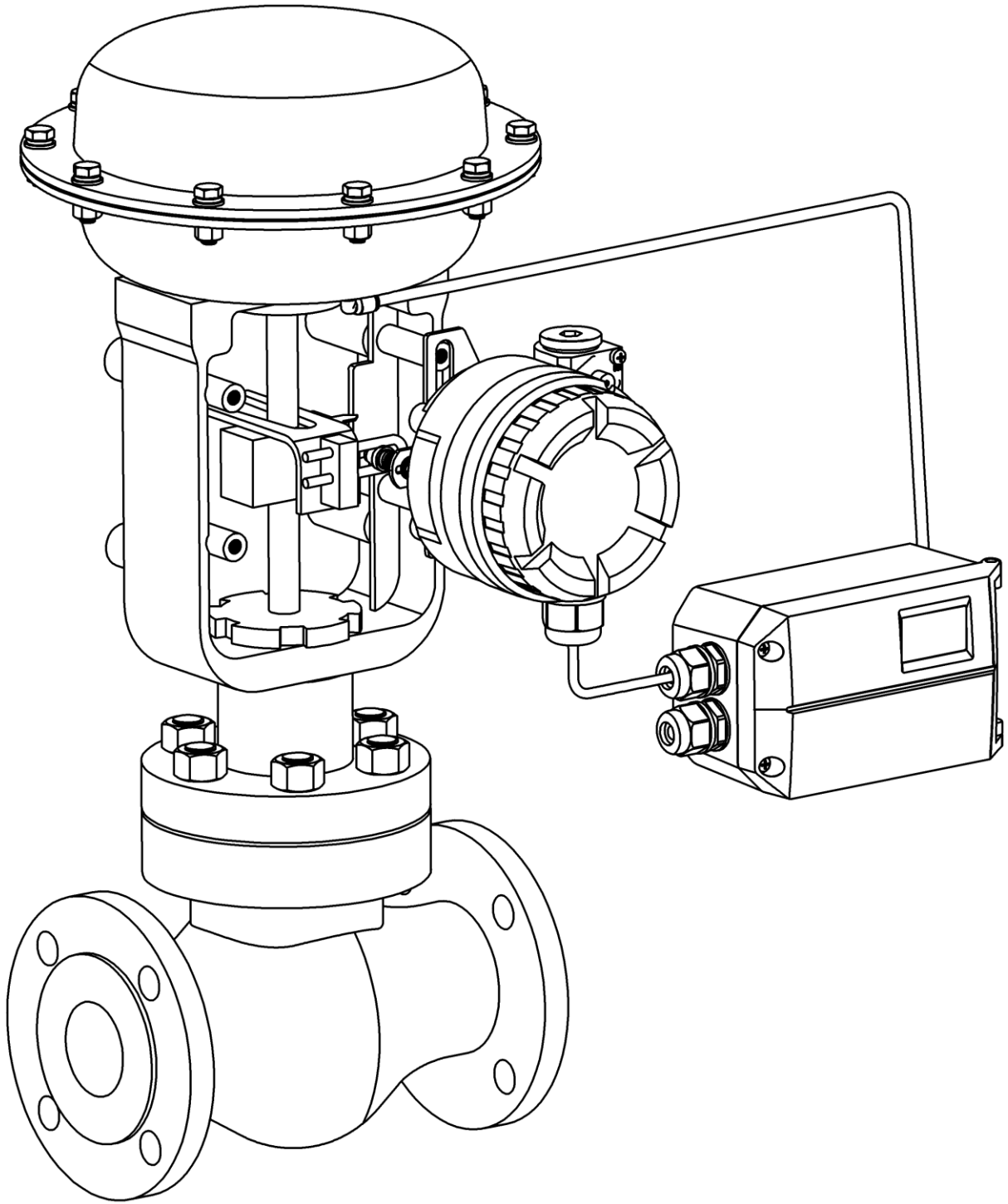

图27. 远传型直行程 (反馈杆 B)

7.1.2. 无管路连接安装

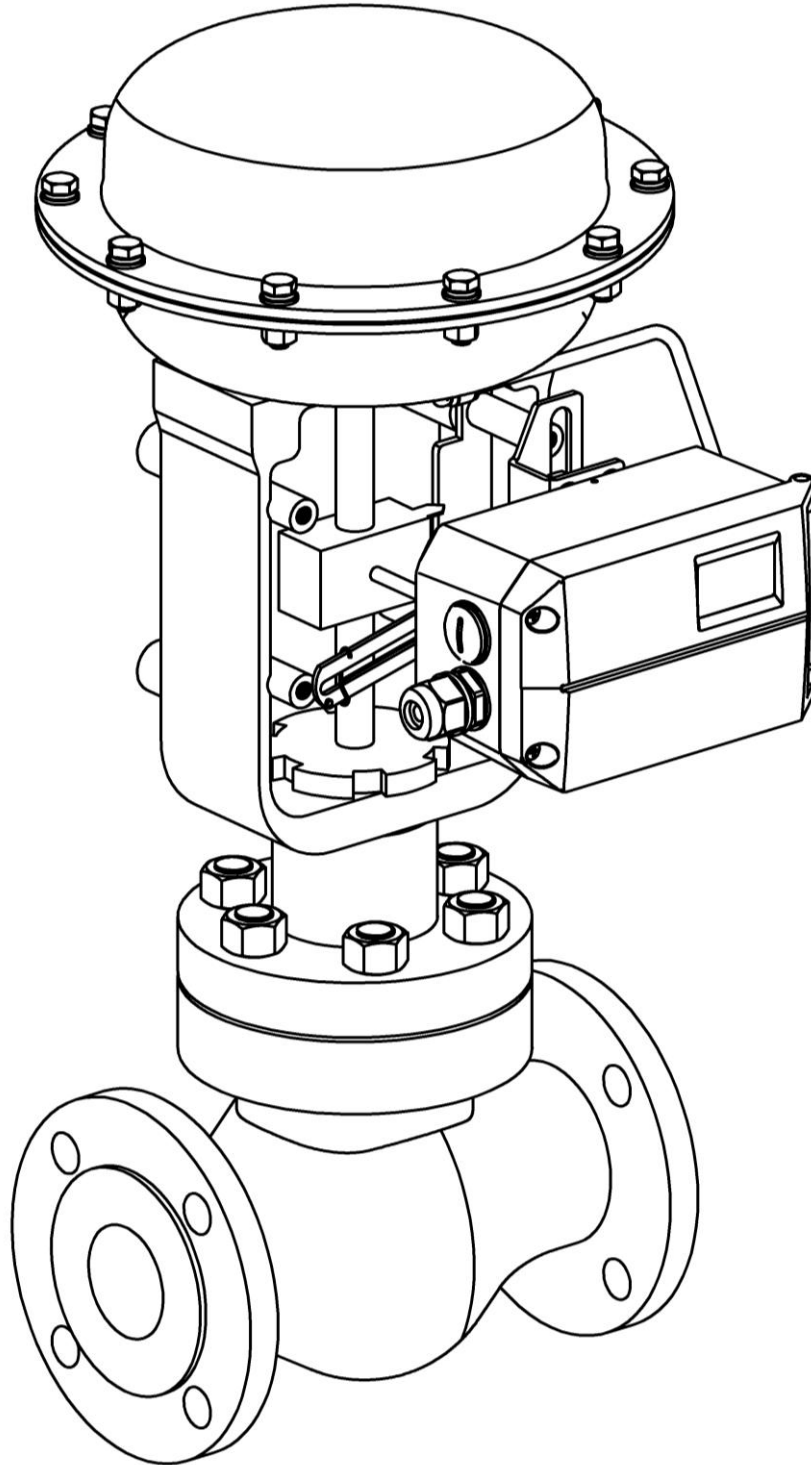

图28. 无管路连接孔及安装固定孔相对位置

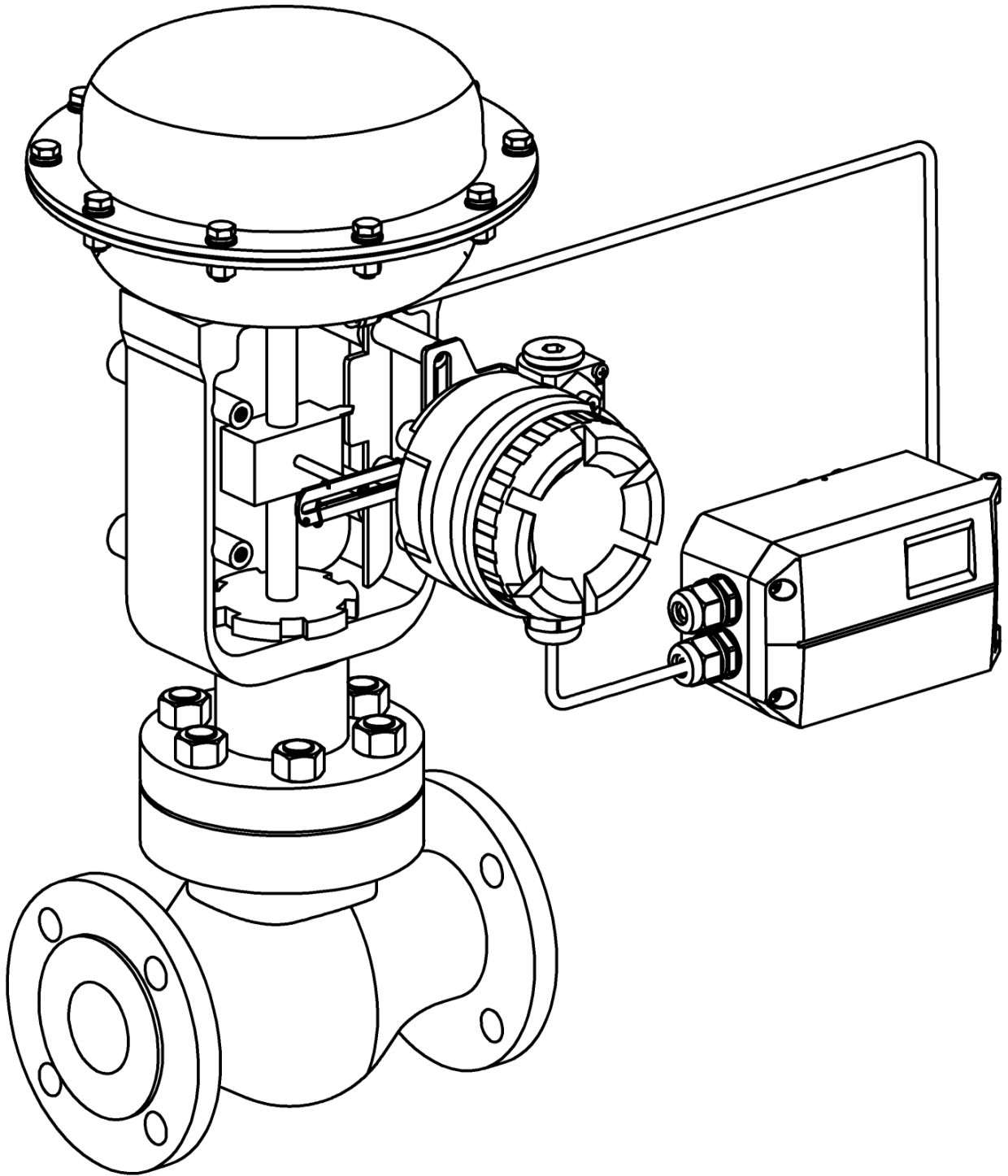
参考常规管路连接安装流程，并注意如下区别：

- 用一字螺丝刀拆除壳体背面的无管路连接口的堵头，用 1/4"堵头堵住出气口 OUT1 和 OUT2。如图 29 所示。

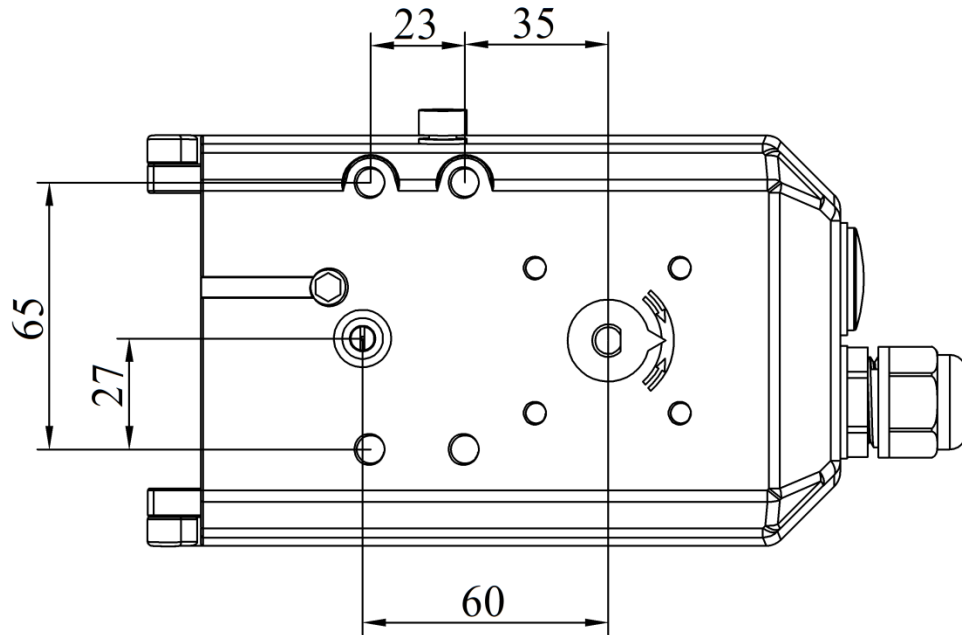

图29. 堵头和出气口示意图

- 无需安装支架。用 2 个 M8 的长螺丝把定位器固定在无管路连接型执行机构上。确认无管路连接口的密封圈完好，确认反馈杆是否正确连接在执行机构轴上。

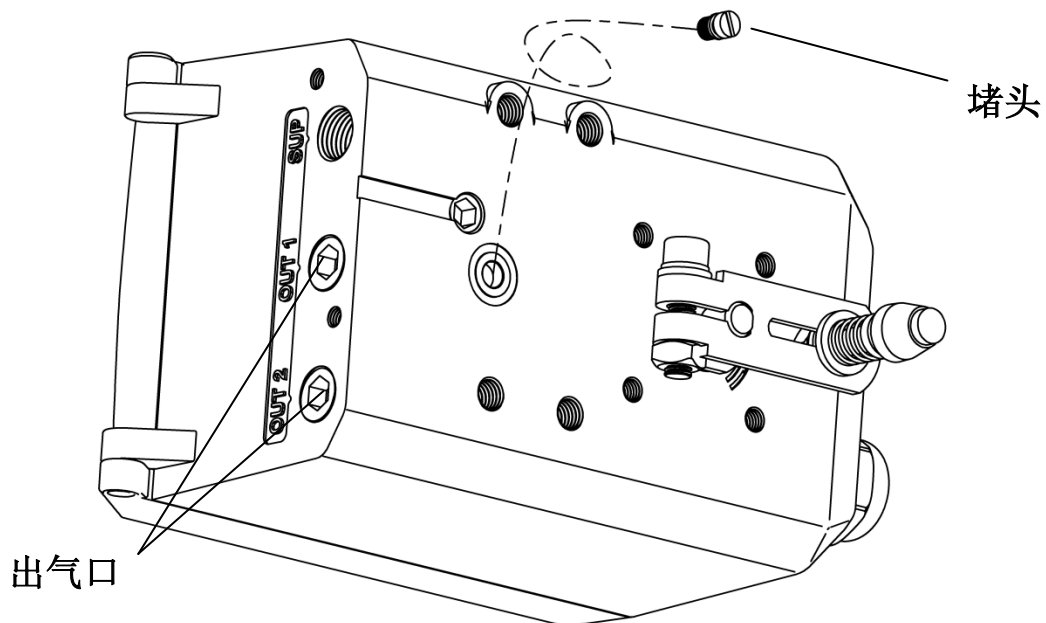

图30. 安装到无管路连接型执行机构上

7.2. 角行程（常规型或远传型）

角行程执行机构安装组件			
序号	名称	数量	注意
①	适配器	1	安装在定位器主轴上
②	内六角紧定螺钉	2	M4×8，固定适配器于主轴上
③	角行程安装支架	1	可兼容不同规格的执行器
④	M6 平垫圈	4	保护接触表面
⑤	M6 弹簧垫圈	4	防止螺钉松动
⑥	M6 内六角螺钉	4	M6×10
⑦	M5 内六角螺钉	4	M5×8
⑧	M5 弹簧垫圈	4	防止螺钉松动
⑨	M5 平垫圈	4	保护接触表面

安装前注意事项：

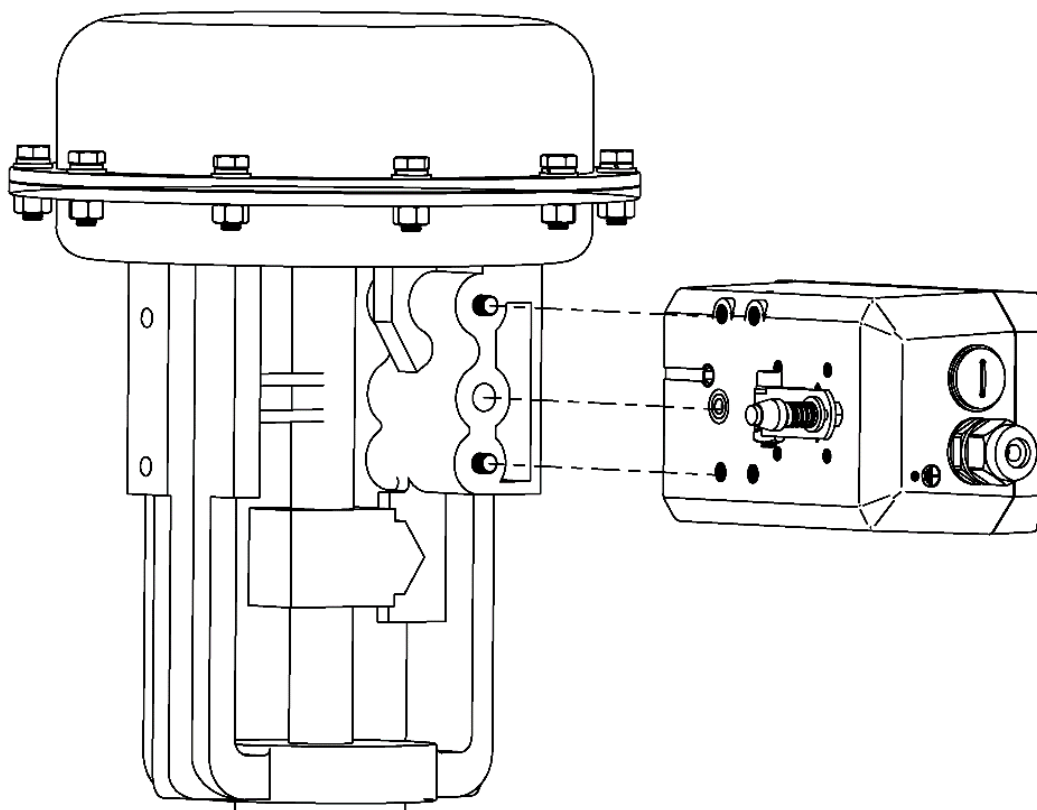
请先做好以下准备，安装步骤中以图 31 所示第一种情况为例进行配图。图 31 中标注了执行器转动轴在初始位置处的插槽方向和旋转方向。↓ 指示执行器气动接口位置。

- 将执行器转动轴调到初始位置。对于单作用执行器，将执行器气缸排空空气。对于双作用执行器，将内部一个气缸排空空气，一个气缸充满空气。注意转动轴在初始位置处的

插槽方向。

- 确定执行器转动轴的旋转方向。对于单作用执行器，从初始位置开始对执行器气缸进气。对于双作用执行器，从初始位置开始，对排空空气的气缸进气，对充满空气的气缸排气。以此来判断转动轴的旋转方向。
- 将定位器反馈轴的指针旋转至对应图示位置，务必在转动标识范围内转动反馈轴。
- 将适配器以对应图示方向放置。

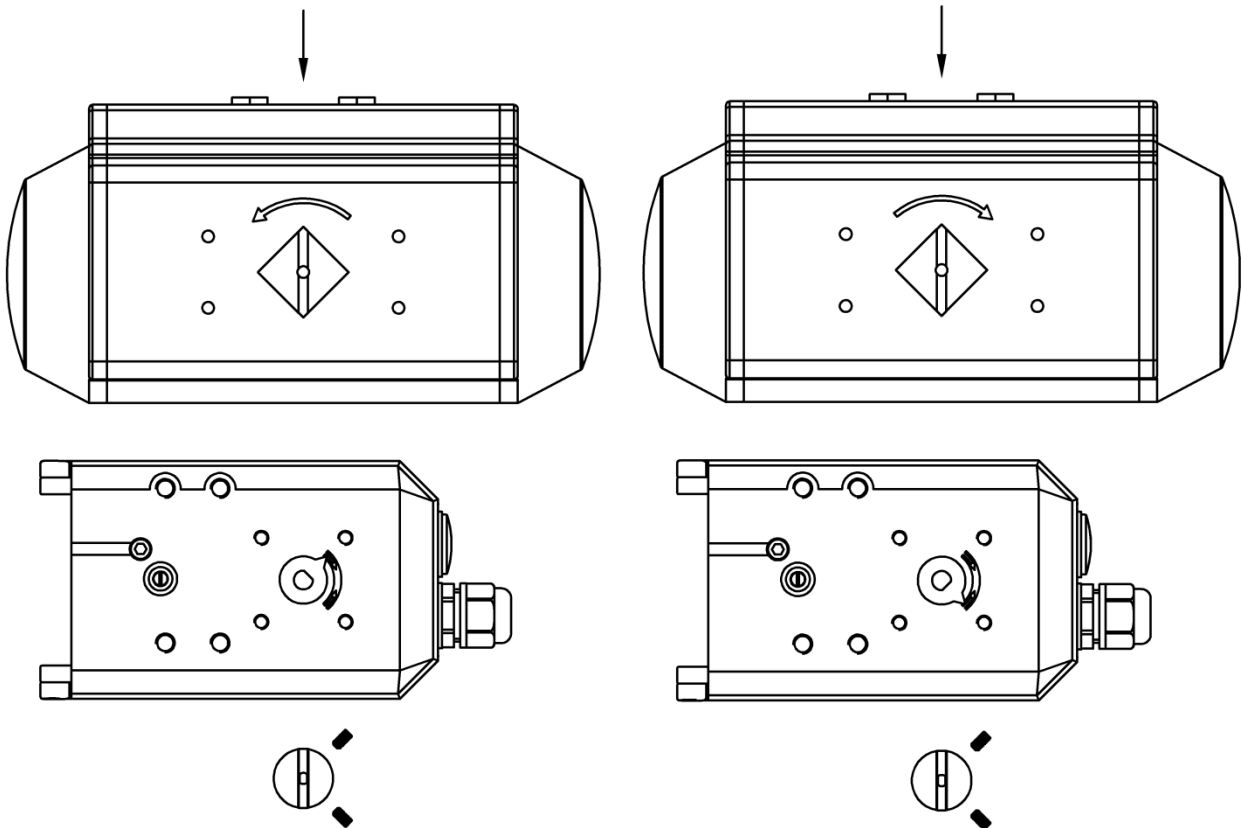



图31. 四种情况安装匹配

- 注意远传型与常规型之间的区别，远传型的安装请参考常规型。

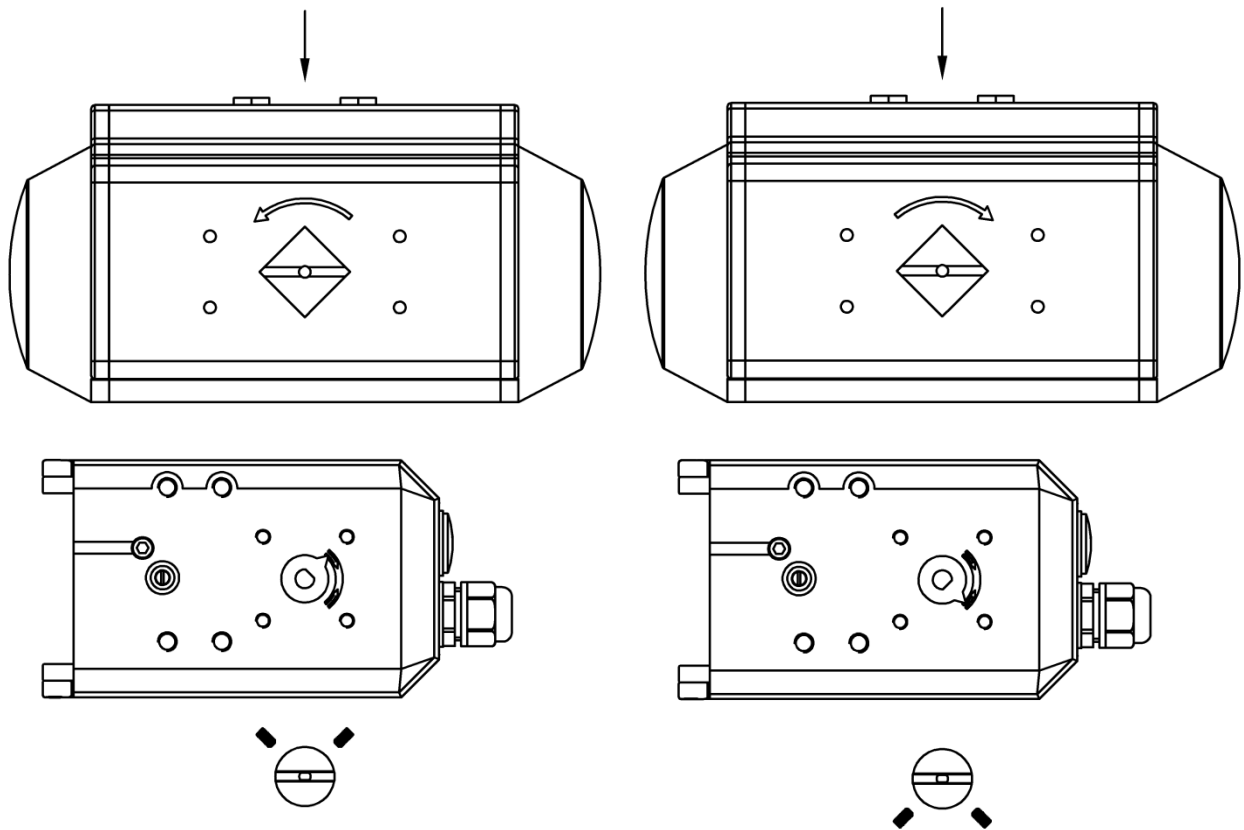

图32. 远传型与常规型反馈轴指针对照

1. 确认定位器或远传型传感器反馈轴的初始位置（操作同 7.1 章节直行程安装）。
2. 把适配器安装在定位器或远传型传感器的反馈轴上。

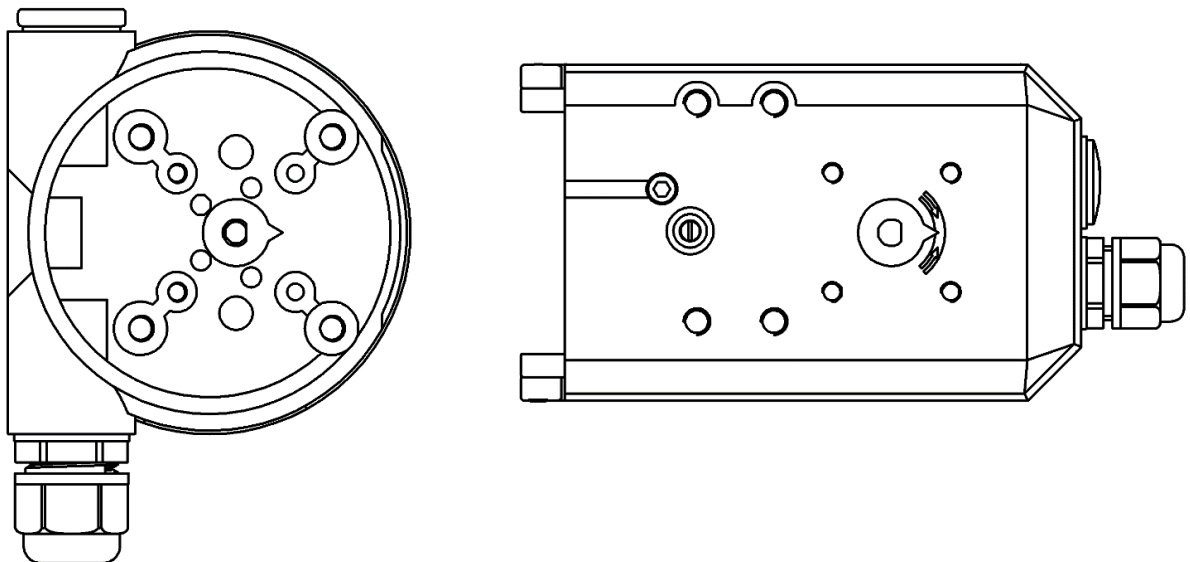

图33. 适配器安装

把适配器按照准备时的摆放方向装到反馈轴上，并用紧定螺钉②将其固定；确保紧定螺钉之一锁紧在反馈轴的平坦一侧。

3. 把角行程安装支架安装到定位器或远传型传感器的底部。

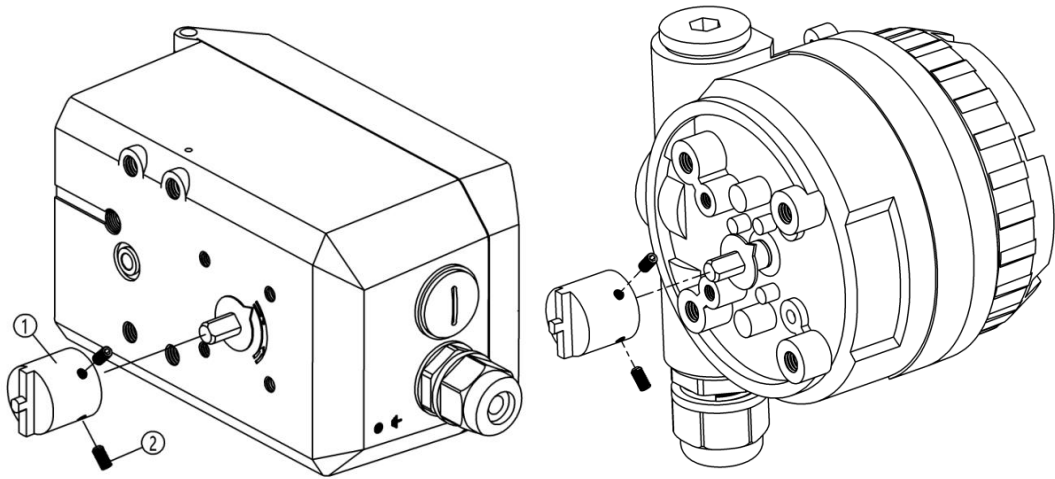

图34. 角行程安装支架安装

4. 把角行程安装支架固定到执行器上。

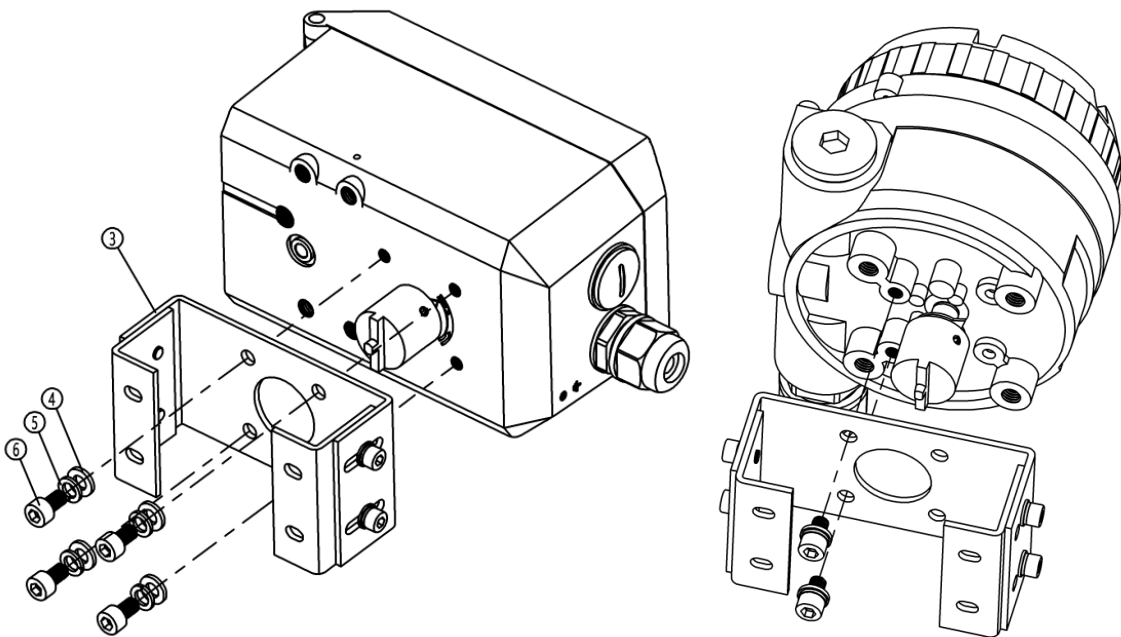

图35. 与执行器安装

5. 整体示意图。



图36. 常规型角行程

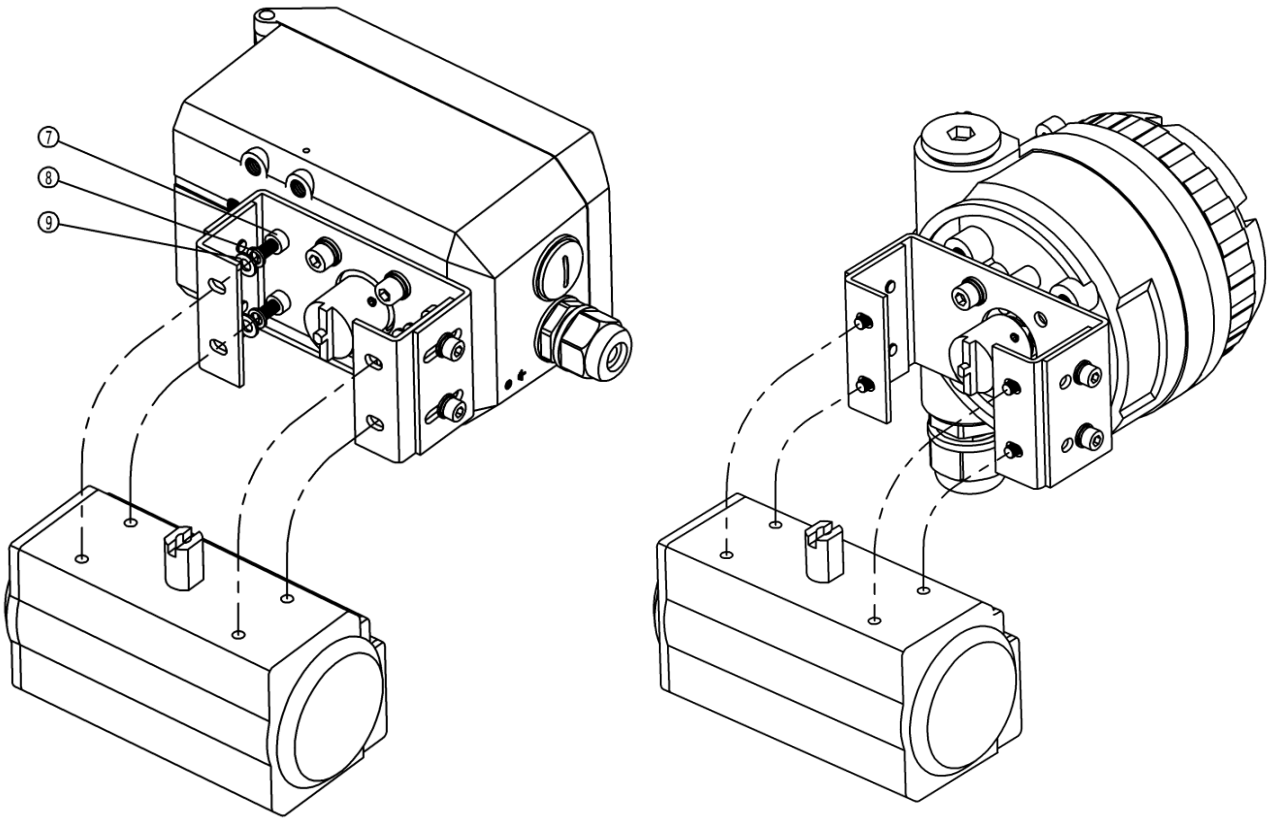

图37. 远传型角行程

7.3. 分体式

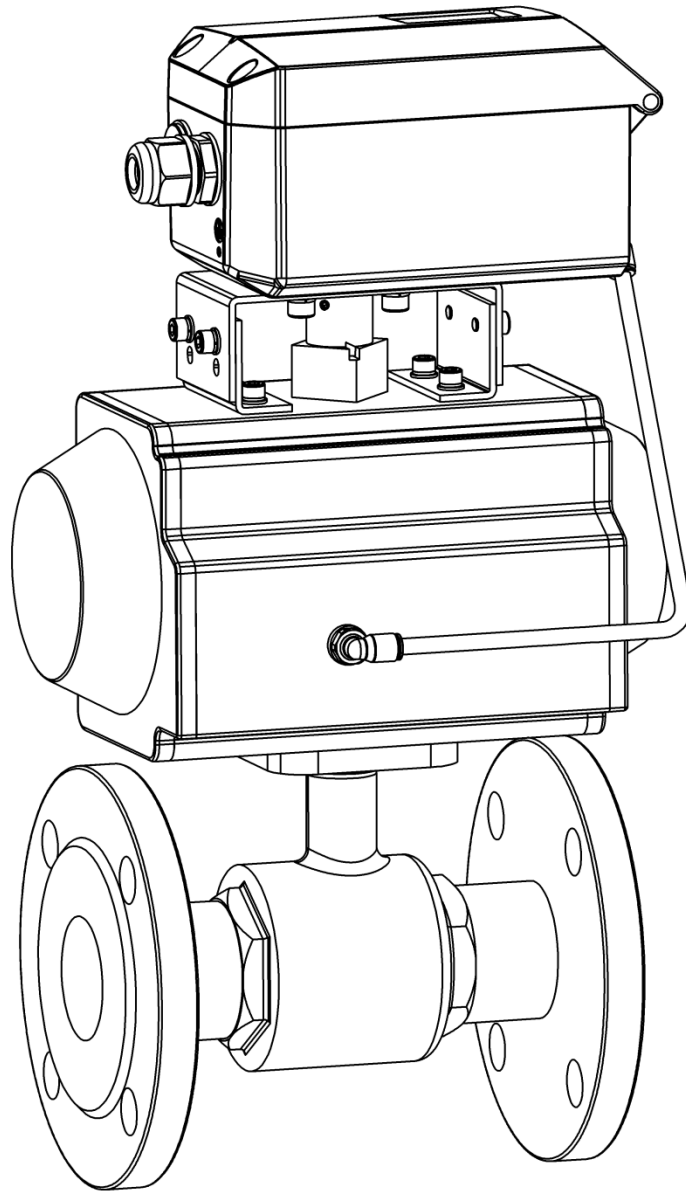
分体式安装组件			
序号	名称	数量	注意
①	传感器	1	反馈阀门开度位置
②	安装板	1	连接定位器与执行器
③	O 型圈	2	$\Phi 20 \times 2$
④	固定件	2	用于固定安装板, G1/4 螺纹
⑤	M8 六角头螺栓	4	M8 \times 16
⑥	传感器接头	1	将传感器连接到定位器

1. 传感器与执行器组装。

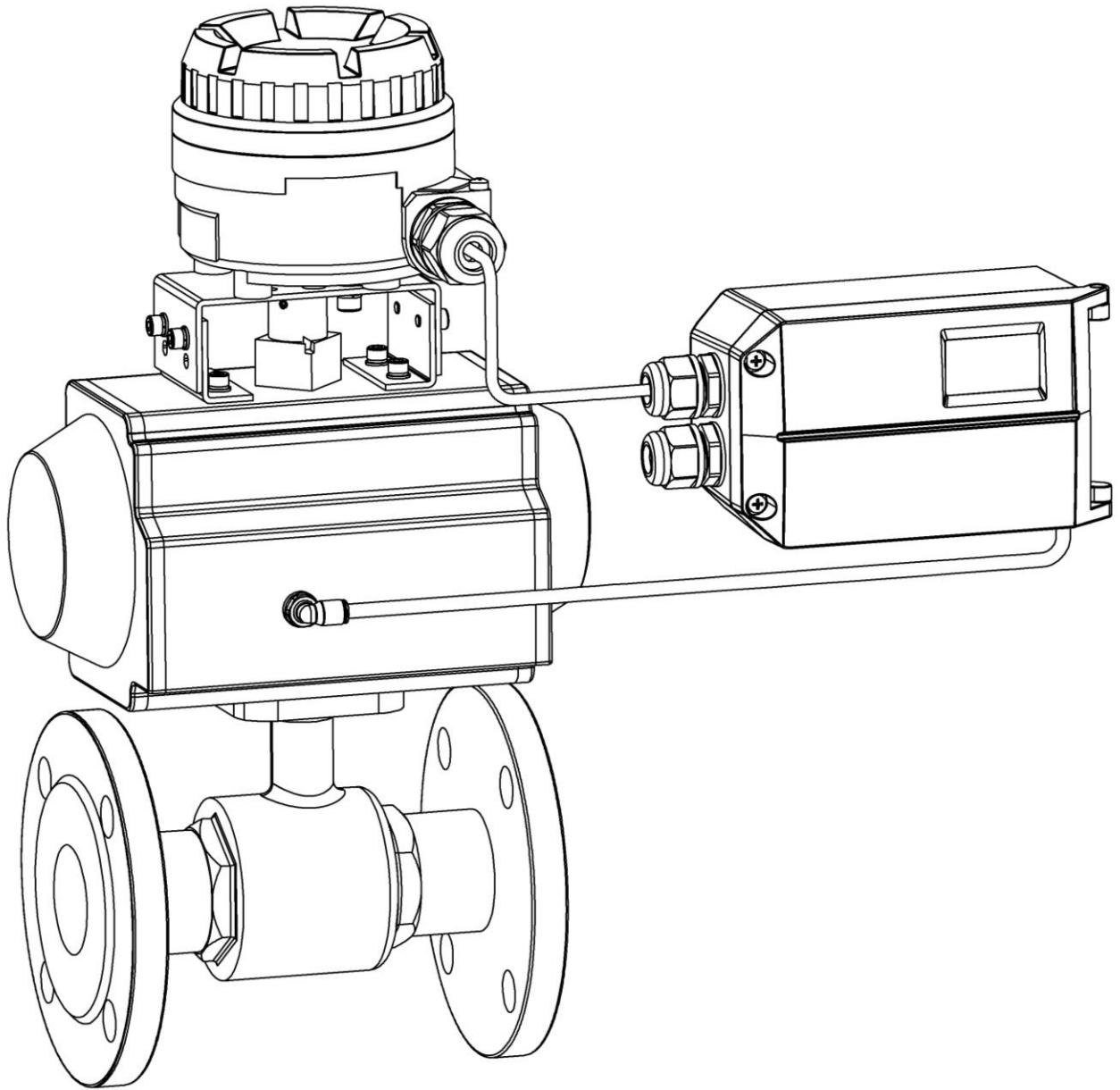
- 确认执行器阀门行程值和执行器顶部螺纹规格是否相符。
- 阀门处于完全关闭和完全打开状态时, 用深度尺分别测量执行器阀杆顶端到执行器顶部安装基准面的距离 C1 值和 C2 值 (图 38 中标注所示), 并记录。



图38. C1 值和 C2 值测量

- 调节位移传感器的调节螺母, 然后在位移传感器完全松开状态下用深度尺测量 D 值 (图 39 中标注所示)。计算压缩量 $L1 = D - C1$, $L2 = D - C2$ 。建议尽可能使 L1 和 L2 的值在下表所示的参考范围内。如果 L1 或 L2 的值无法满足在下表所示的参考范围内, 则可根据实际情况调节 D 值。

注意：调节的 D 值必须保证使 $L1 > 0$ ， $L2 <$ 位移传感器最大压缩量。否则将无法匹配。

阀门最大行程	D 值范围	压缩量 L1, L2 参考范围
5~25 mm	45~51 mm	3~28 mm
25~50 mm	65~71 mm	3.5~53.5 mm

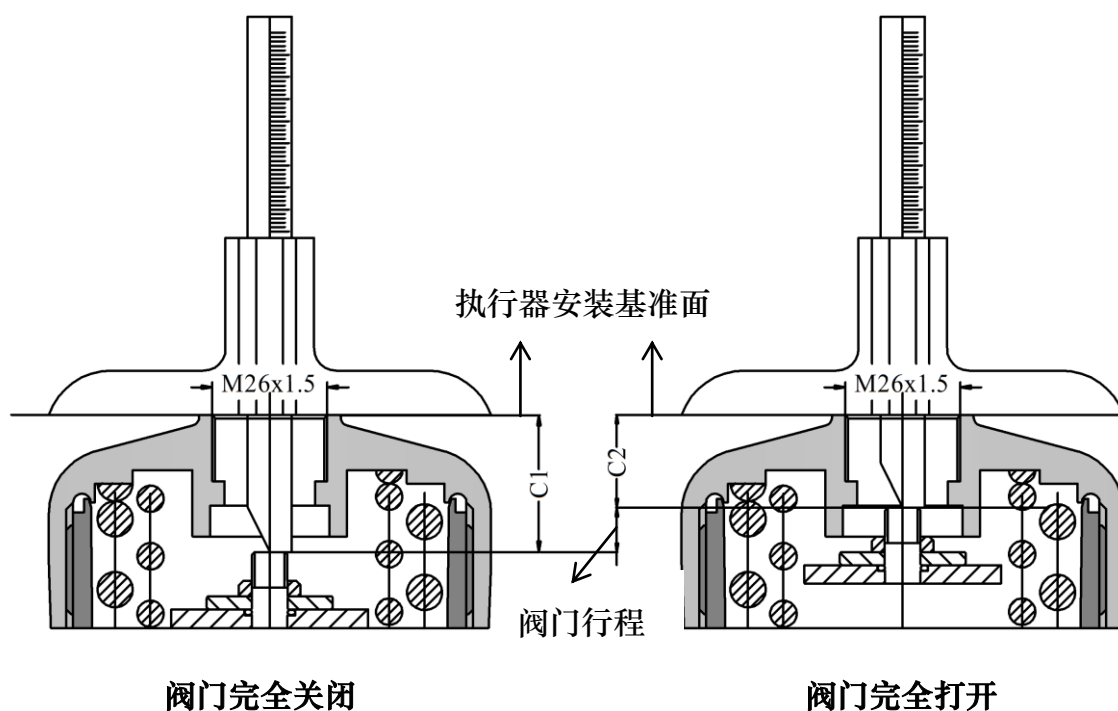

图39. 调节 D 值

- 将执行器内部阀杆升到最高位置，用 32 号扳手将传感器底部的执行器连接组件右旋入到执行器对应螺纹接口，并确保旋紧连接组件。

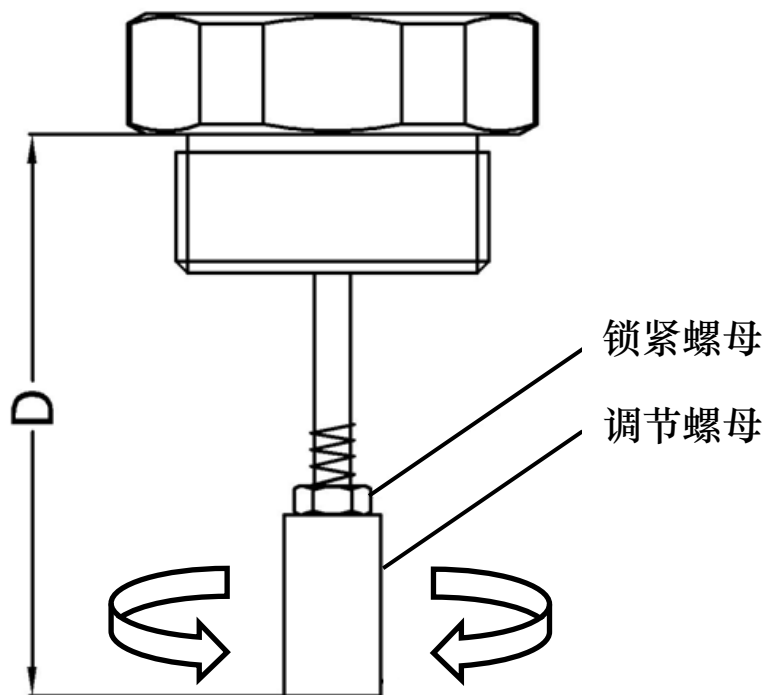

图40. 传感器安装

2. 固定安装板。

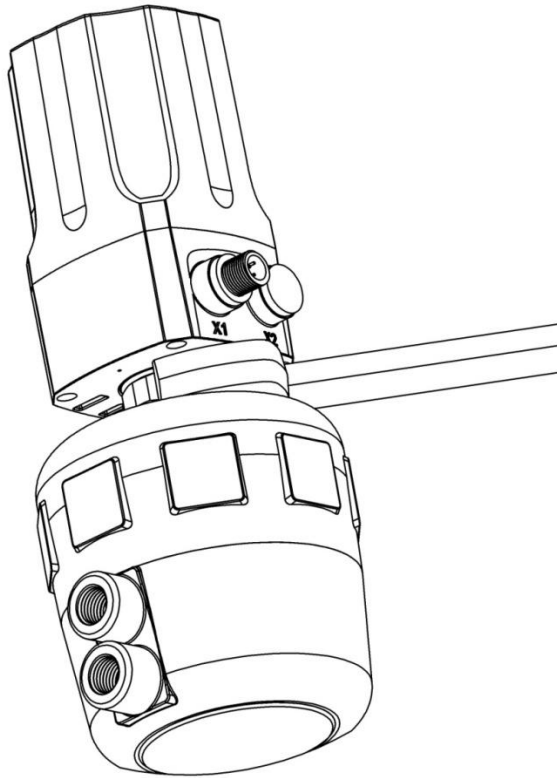

图41. 固定安装板

将 O 型圈③放入安装板②相应密封槽内,用固定件④把安装板②固定于执行器相应位置,使用内六角扳手拧紧。(O 型圈与执行器接触平面应光滑平整并能完全罩住 O 型圈。固定件④的螺纹规格为 G1/4, 执行器上对应的螺纹规格同样为 G1/4 才能安装。)

3. 把定位器固定在安装板上。

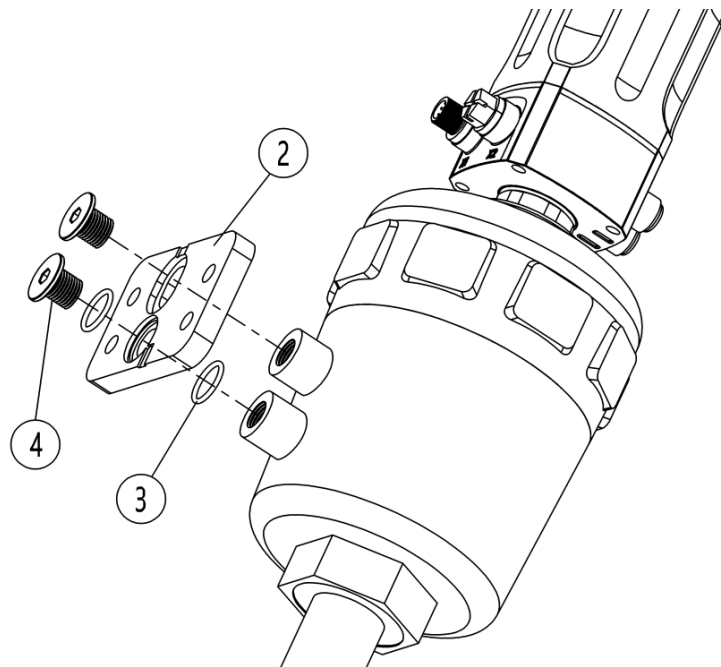

图42. 固定定位器

用六角头螺栓⑤将定位器固定于安装板上，使用扳手拧紧。

4. 连接传感器。

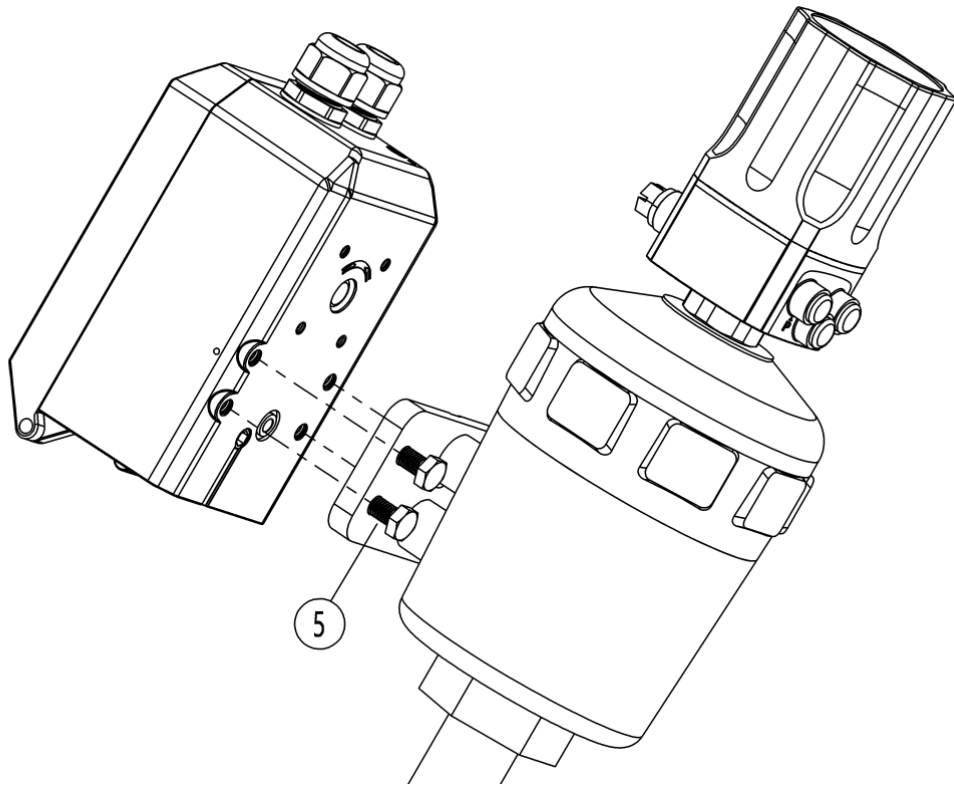

图43. 连接传感器

将传感器接头⑥插入传感器相应位置并拧紧。(注意：安装时注意先将传感器接头插入下图相应限位处再拧紧，防止传感器接头损坏)

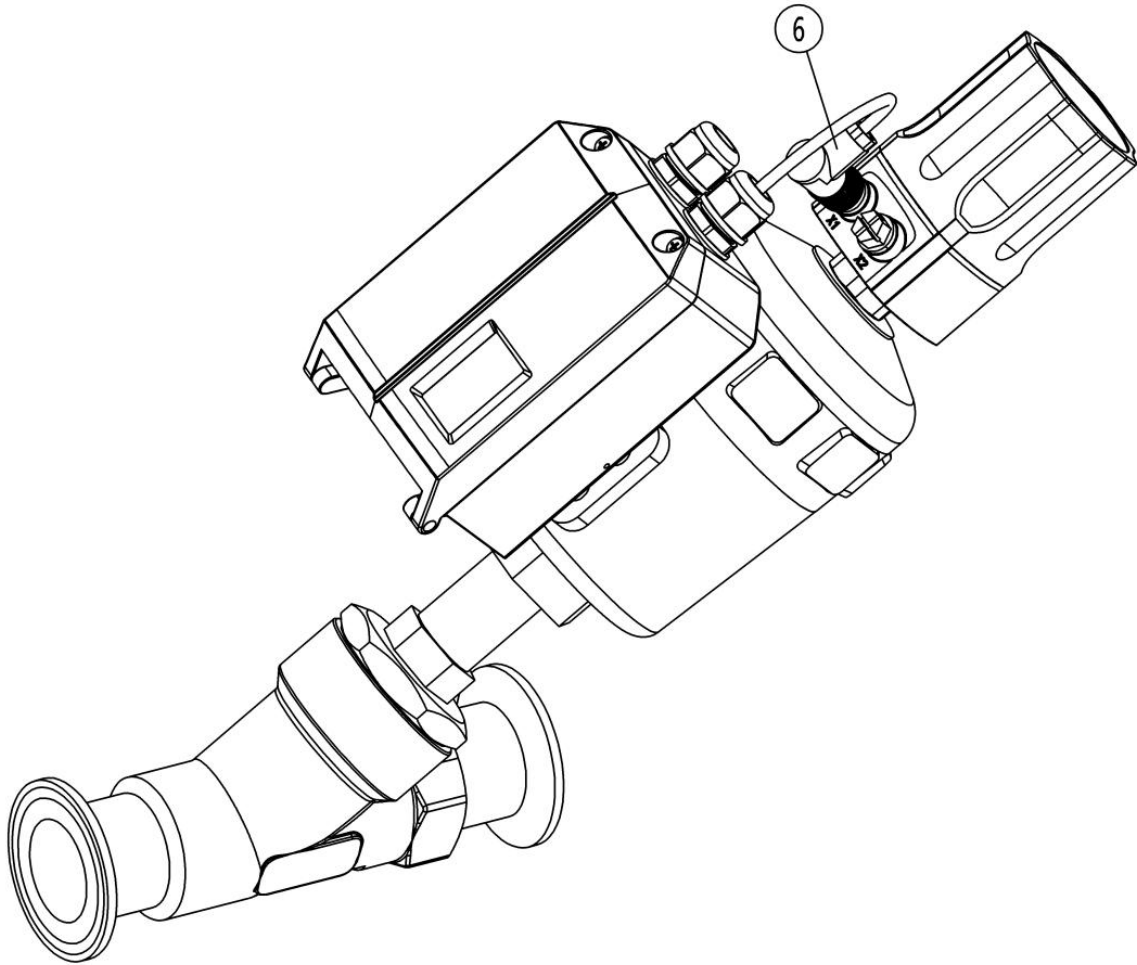

图44. 传感器接头

8. 操作

8.1. 界面描述



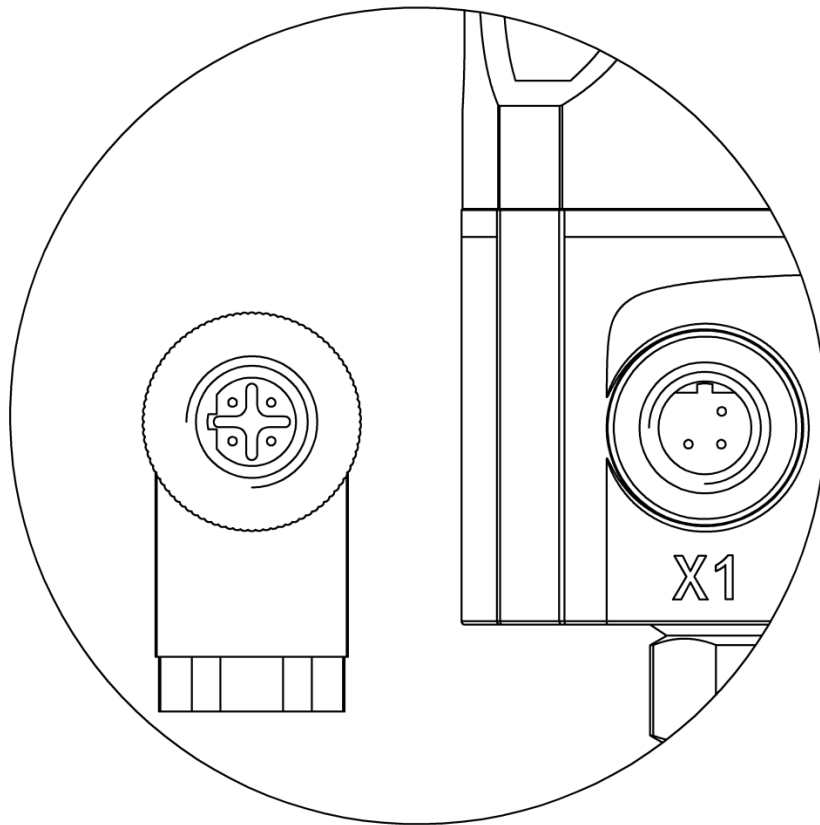



用户操作界面由一个 LCD 和 4 个按键组成。

LCD 显示说明

位置	描述
第一行	<ul style="list-style-type: none"> ● 初始界面 (NOINI) 或运行初始化功能时显示角度传感器百分比值。 ● 工作模式下显示阀位百分比值。 ● 菜单模式下显示参数值。
第二行	<ul style="list-style-type: none"> ● 未初始化状态下显示提示标志。 ● 工作模式下显示自动或手动模式。 ● 工作模式下设定百分比值。 ● 菜单模式下显示功能选项。

- 初始化过程中显示初始化进程和错误提示。

按键操作说明

按键	操作说明
	<ul style="list-style-type: none"> ● 进入系统菜单。 ● 工作模式下手自动模式切换。 ● 从系统菜单退出到主界面。 ● 从子菜单退出到上一级菜单。
	<ul style="list-style-type: none"> ● 初始界面 (NOINI) 下打开或关闭阀门。 ● 手动模式下减小阀位值。如果先按住此键，再按住键，阀位值快速减少。 ● 菜单模式下向下选择功能选项、参数或减小数值参数值。
	<ul style="list-style-type: none"> ● 初始界面 (NOINI) 下打开或关闭阀门。 ● 手动模式下增加阀位值。如果先按住此键，再按住键，阀位值快速增加。 ● 菜单模式下向上选择功能选项、参数或增加数值参数值。
	<ul style="list-style-type: none"> ● 菜单模式下进入子菜单、使能或确认参数修改。 ● 菜单模式下运行初始化或恢复出厂设置。 ● 初始界面 (NOINI) 或手自动模式界面运行初始化功能。

8.2. 主界面显示和操作

系统在没完成初始化功能前处于未初始化状态。显示标志为 NOINI，界面第一行显示传感器百分比值。如图 45 所示。





图45. 未初始化状态界面

在此状态下，操作键可打开或关闭阀门。将阀门全开和全闭，观察界面上显示传感器百分比值。对于非分体式，确保在整个阀门行程范围内，传感器百分比最小值 $\geq 5\%$ ，传感器百分比最大值 $\leq 95\%$ 。否则，需要重新调整安装位置使直行程反馈杆或角行程适配器在有效范围内动作。对于分体式，确保在阀门行程 5-25mm 范围内，传感器百分比最小值 $\geq 12\%$ ，

传感器百分比最大值 $\leq 92\%$ ；在阀门行程 25-50mm 范围内，传感器百分比最小值 $\geq 2\%$ ，传感器百分比最大值 $\leq 97\%$ 。否则，需要调整传感器 D 值。另外，要求传感器最小最大百分比差值大于 16%（非分体式）或 8%（分体式）。

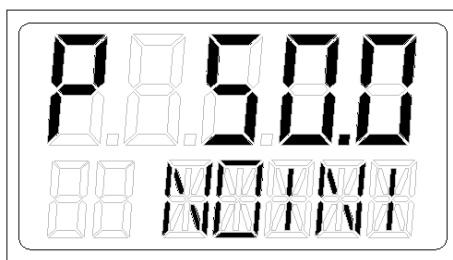
如果要快捷操作自动初始化（INITA）功能，则在初始界面（NOINI）或手自动模式界面长按 \square 键 3 秒左右开始运行自动初始化。初始化运行过程中按 \square 键可退出。退出后，如果之前初始化完成过，则进入手动模式界面，否则进入初始界面（NOINI）。初始化完成后，按 \square 键退出。退出后，系统进入手动模式界面。

系统工作模式分为自动模式和手动模式。

在自动模式下，系统接收主站发送的有效 SP 值自动调节阀门开度。

在手动模式下，通过手动操作 $\blacktriangledown/\blacktriangle$ 键来调节阀门开度。

主界面上第一行显示阀位百分比值，第二行显示设定百分比值。其中第二行设定百分比显示值最后一个数值为一位小数。符号 A 表示自动模式，符号 M 表示手动模式。可通过按键 \square 切换自动模式和手动模式。键按住后松开时间小于进入菜单操作的时间则进行手自动模式切换，否则进入菜单。如图 46 所示。



图46. 系统工作模式界面

在自动模式下，当使能安全位置功能时，界面上显示符号 F。如果菜单 SAFE 选项参数为 ACT，则设定值处显示----。如图 47 所示。



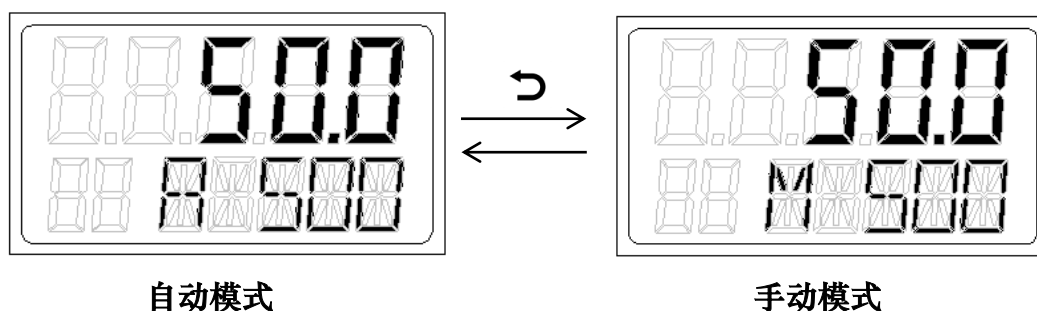

图47. 使能安全位置功能的自动模式界面

8.3. 菜单和功能

8.3.1. 菜单显示和操作

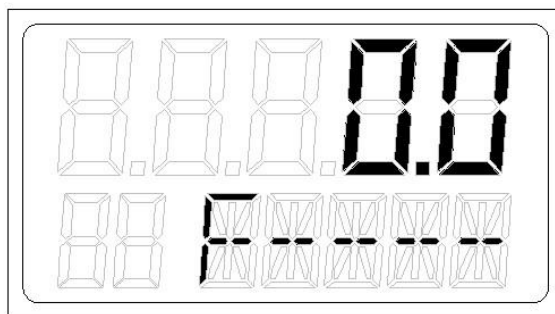
长按  键 3 秒左右，系统进入菜单。菜单界面显示内容描述如图 48 所示。在菜单界面，按  键，系统从菜单界面退出到手动模式工作界面。



图48. 菜单界面



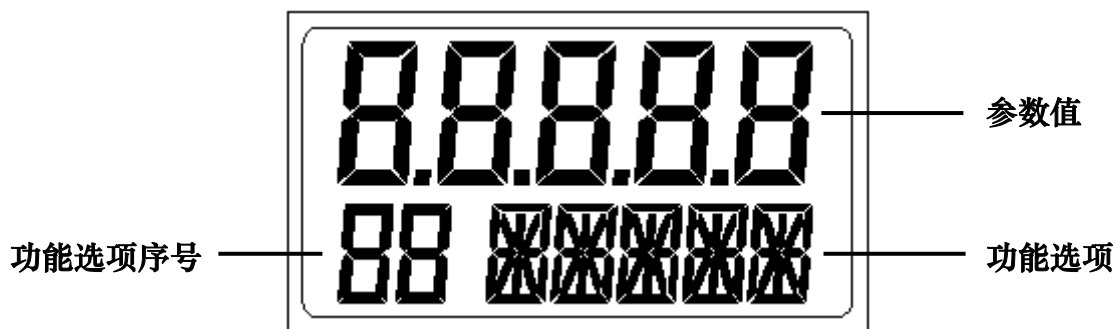

8.3.2. 功能描述和操作

8.3.2.1. TYPE

选择执行机构类型。

设置参数选项

选项	描述
Lin	安装反馈杆 A 的直行程执行机构。
Turn	角行程执行机构。
FLin	安装反馈杆 B 的直行程执行机构。
ELin1	分体式执行机构。行程范围：5-25mm。
ELin2	分体式执行机构。行程范围：25-50mm。

菜单界面选择此功能，按  键开启参数设置，参数闪烁显示。按   键设置参数。按  键确认修改。

8.3.2.2. INITA

该功能为自动初始化。该功能自动检测动作方向，阀门实际物理行程，控制参数。







菜单界面选择此功能，长按  键 3 秒左右开始运行，LCD 左下角出现滚动标志，第一行显示传感器百分比值，第二行显示运行步骤。自动初始化完成后，LCD 上显示 FINSH。

自动初始化过程中由于某些原因，系统会在功能选项栏显示错误提示。并中断初始化。错误提示说明及处理方法详见 8.3.3 章节。

8.3.2.3. INITM

该功能为手动初始化。适用于用户手动来确定阀门行程。

该功能先手动标定阀门行程，再自动检测动作方向，控制参数。操作流程如下：





1. 菜单界面选择此功能，长按  键 3 秒左右开始运行，LCD 左下角出现滚动标志，第一行显示传感器百分比值，第二行显示显示 END 1。
2. LCD 上显示 END 1 后，操作   键将阀位移动至手动标定的行程端点 1，按  键确认，LCD 上显示 END 2。再次操作   键将阀位移动至手动标定的行程端点 2，按  键确认。
3. END 2 确认后，如果 LCD 上没有错误提示，则系统自动从初始化第 1 步开始执行，并跳过第 2 步行程检测。

手动初始化完成后，LCD 上显示 FINSH。

手动初始化过程中由于某些原因，系统会在功能选项栏显示错误提示。并中断初始化。错误提示说明及处理方法详见 8.3.3 章节。

8.3.2.4. SDIR

此功能用来设置设定值方向。

菜单界面选择此功能，按  键开启参数设置，参数闪烁显示。按   键设置参数。按  键确认修改。

设置参数选项

选项	描述
riSE	主站发送的 SP 值越大，阀门开度越大。
FALL	主站发送的 SP 值越大，阀门开度越小。



图49. SDIR

8.3.2.5. CHAR

特性曲线是阀位设定值与阀门行程的转换关系。

在实际控制系统中，通常要求使被控量具有特定的控制特性（比如线性）。用户可以选择和设置相应的特性曲线来达到控制要求。

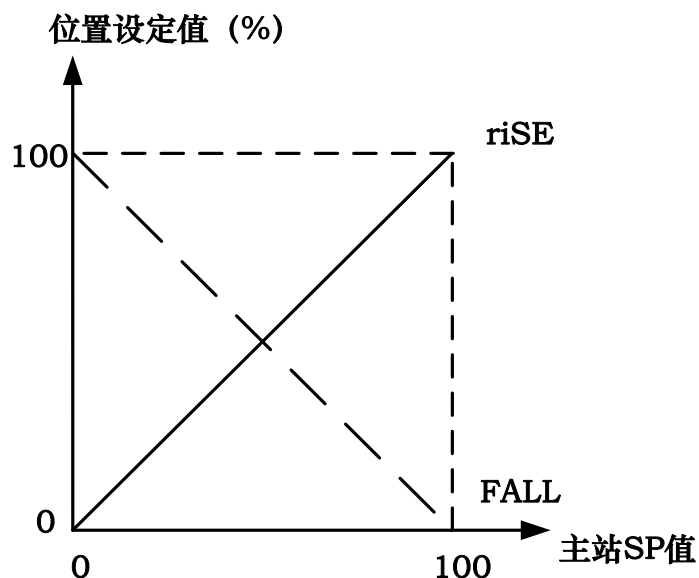
菜单界面选择此功能，按 键开启参数设置，参数闪烁显示。按 键设置参数。按 键确认修改。

特性曲线参数选项

选项	描述
Lin	位置设定值与阀门行程为 1:1 转换关系。
1-25	位置设定值与阀门行程为 1:25 等百分比转换关系。
1-33	位置设定值与阀门行程为 1:33 等百分比转换关系。
1-50	位置设定值与阀门行程为 1:50 等百分比转换关系。
n1-25	位置设定值与阀门行程为 1:25 反等百分比转换关系。
n1-33	位置设定值与阀门行程为 1:33 反等百分比转换关系。
n1-50	位置设定值与阀门行程为 1:50 反等百分比转换关系。
FrEE	用户自由定义位置设定值与阀门行程的转换关系。将 0-100% 的设定值范围等间隔分为 21 个设定点。每个点上都可设置行程范围为 0-100% 的值。可在 FR 0 , FR 5 , ..., FR 100 选项中设置数值。



图50. CHAR

8.3.2.6. FREE

设置 CHAR 功能选项中 FrEE 特性曲线的数值。

FREE 的子功能选项为 FR 0, FR 5, ..., FR100, 共 21 个设定点。

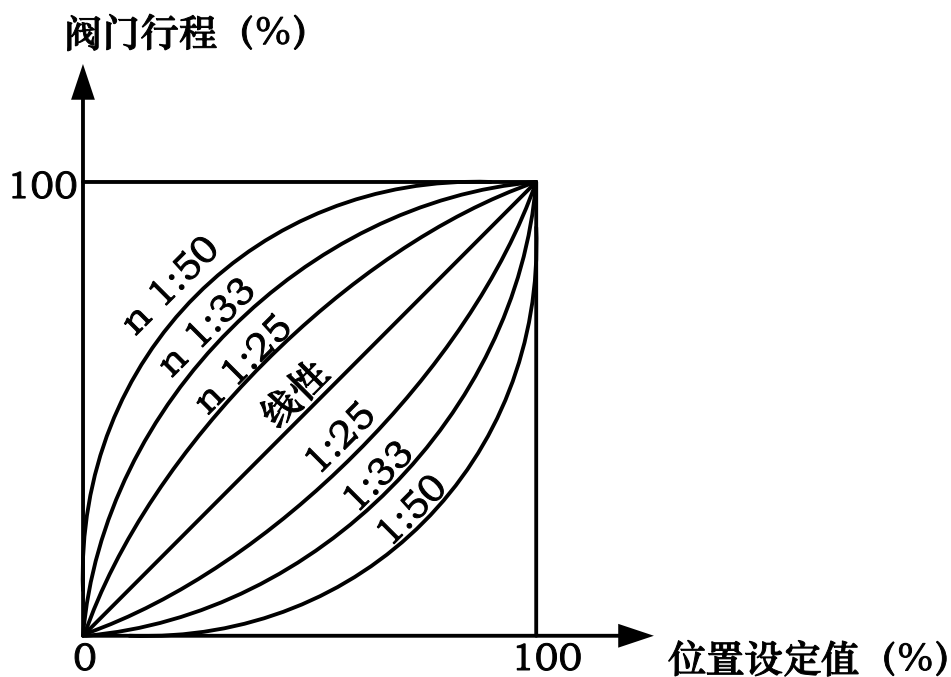
菜单中选择此功能, 按 键进入子功能选择操作, 按 键选择设定点, 按 键开启参数设置, 参数闪烁显示。按 键设置参数, 持续按 键或 键可快速修改参数。按 键确认修改。



图51. FREE

8.3.2.7. DB

定位器死区设置。

阀位值与阀位设定值之间的差值在死区设置范围内时，系统认为调节到位而不做位置调节动作。

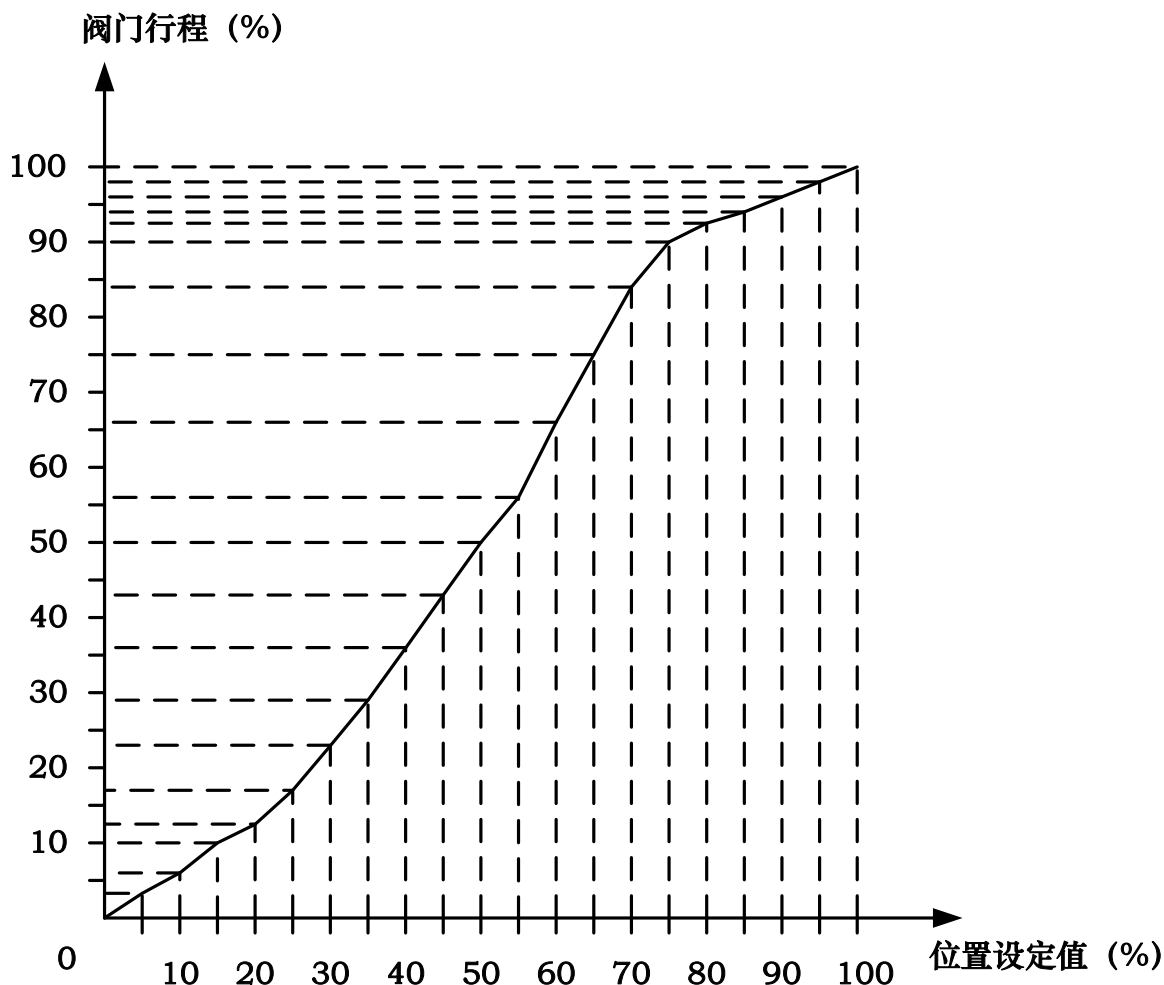
例如，阀位设定值为 50%，死区值为 1%。则实际阀位在 $50 \pm 1\%$ 范围内不做调节动作。如果实际阀位不在 $50 \pm 1\%$ 范围内，则驱动压电模块调节阀位，最终使阀位处于 $50 \pm 1\%$ 范围内。

如果阀位震荡，可将死区调大抑制震荡。死区越小，控制精度就越高。

菜单中选择此功能，按 \odot 键开启参数设置，参数闪烁显示。按 \blacktriangledown / \blacktriangle 键设置参数，持续按 \blacktriangledown 键或 \blacktriangle 键可快速修改参数。按 \odot 键确认修改。

8.3.2.8. LIM

此功能用于限制阀门在物理行程范围内的调节范围。

LIM 的子功能选项 L MIN 和 L MAX 分别设置限制行程的最小最大值。

菜单中选择此功能,按 键进入子功能选择操作,按 键选择子功能选项 L MIN 或 L MAX,按 键开启参数设置,参数闪烁显示。按 键设置参数,持续按 键或 键可快速修改参数。按 键确认修改。



图52. LIM

8.3.2.9. YDIR

此功能用于设置位置值显示和设定值显示的动作方向。

菜单界面选择此功能,按 键开启参数设置,参数闪烁显示。按 键设置参数。按 键确认修改。

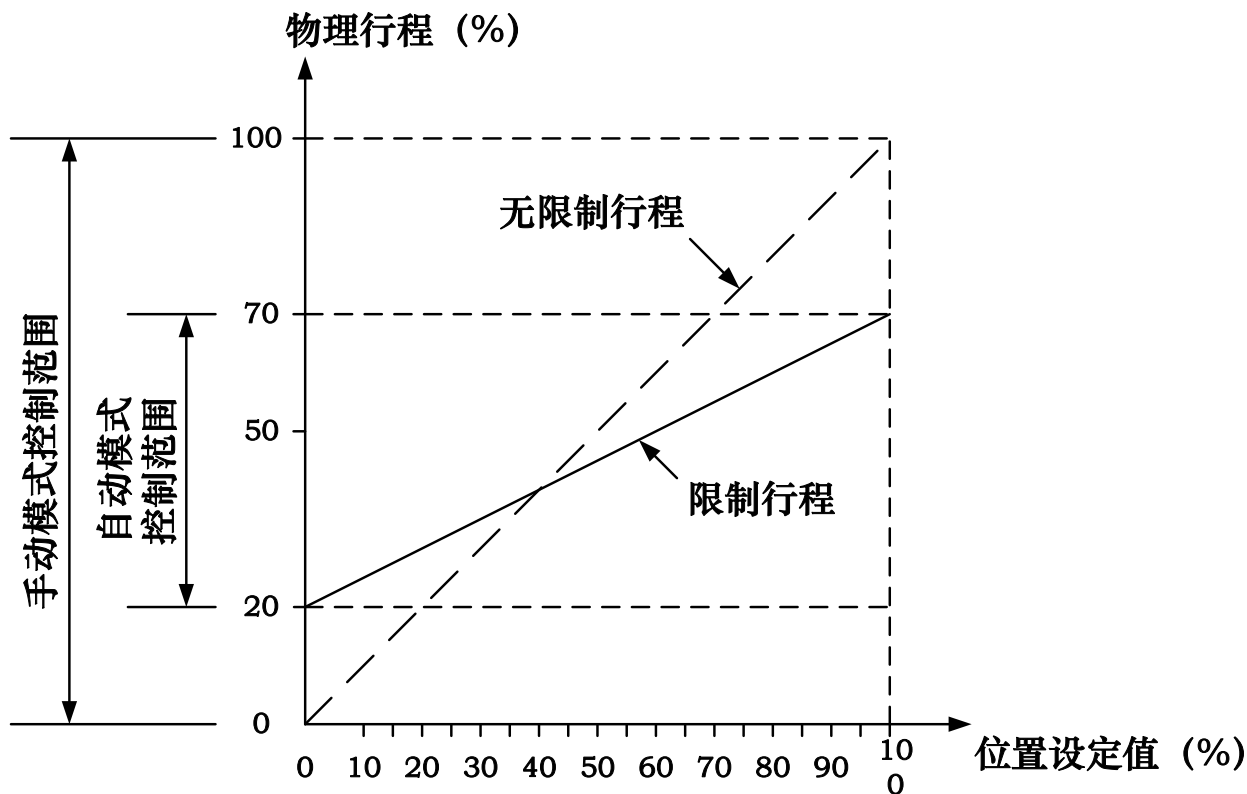
设置参数选项

选项	描述
riSE	位置值显示和设定值显示为上升趋势。
FALL	位置值显示和设定值显示为下降趋势。

8.3.2.10. CUT

此功能用于定位器在自动模式下使阀门完全关闭或完全打开。当紧闭功能使能后,主界

面左下角显示 CU 标志。

CUT 的子功能选项 C MIN 和 C MAX 分别设置紧闭最小最大值。

菜单中选择此功能,按 \odot 键进入子功能选择操作,按 ∇/\blacktriangle 键选择子功能选项 C MIN 或 C MAX,按 \odot 键开启参数设置,参数闪烁显示。按 ∇/\blacktriangle 键设置参数,持续按 ∇ 键或 \blacktriangle 键可快速修改参数。按 \odot 键确认修改。

当 C MIN 为 0 时,完全关闭不起作用。当 C MAX 为 100 时,完全打开不起作用。

在阀门定位状态,当设定值 \leq C MIN 时,阀门完全关闭;当设定值 \geq C MAX 时,阀门完全打开。

在完全关闭状态,当设定值 $>$ C MIN + 1% 时,阀门脱离完全关闭状态。

在完全打开状态,当设定值 $<$ C MAX - 1% 时,阀门脱离完全打开状态。



图53. CUT

8.3.2.11.POS

此功能用于设置位置值显示的标准。

菜单界面选择此功能,按 \odot 键开启参数设置,参数闪烁显示。按 ∇/\blacktriangle 键设置参数。

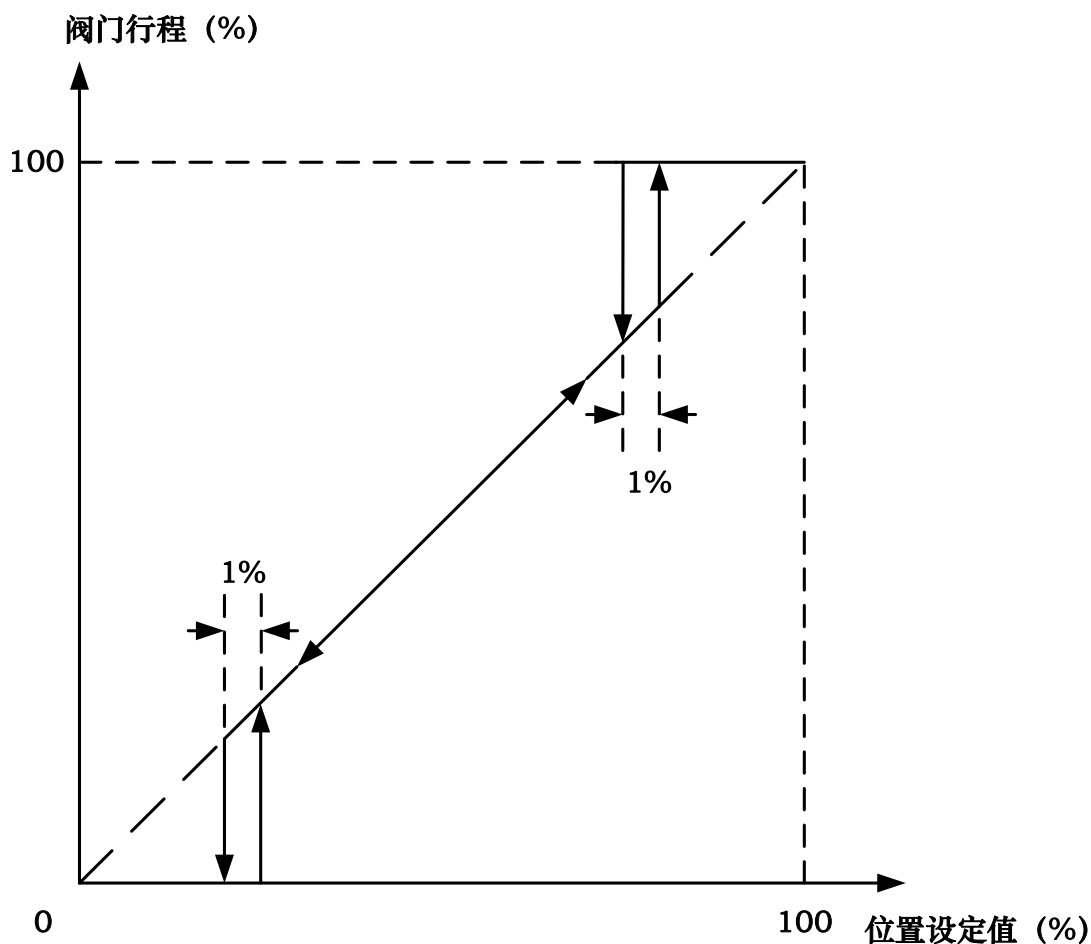
按  键确认修改。

设置参数选项

选项	描述
FS	位置显示对应机械行程 0-100%。设定值以实际阀位设定值显示。不受 L MIN 和 L MAX 参数影响。
LS	位置显示采用 0-100% 的形式来表示 L MIN 和 L MAX 参数之间的范围。设定值以此标准显示。



图54. 示例: POS = FS, L MIN = 20%, L MAX = 90%





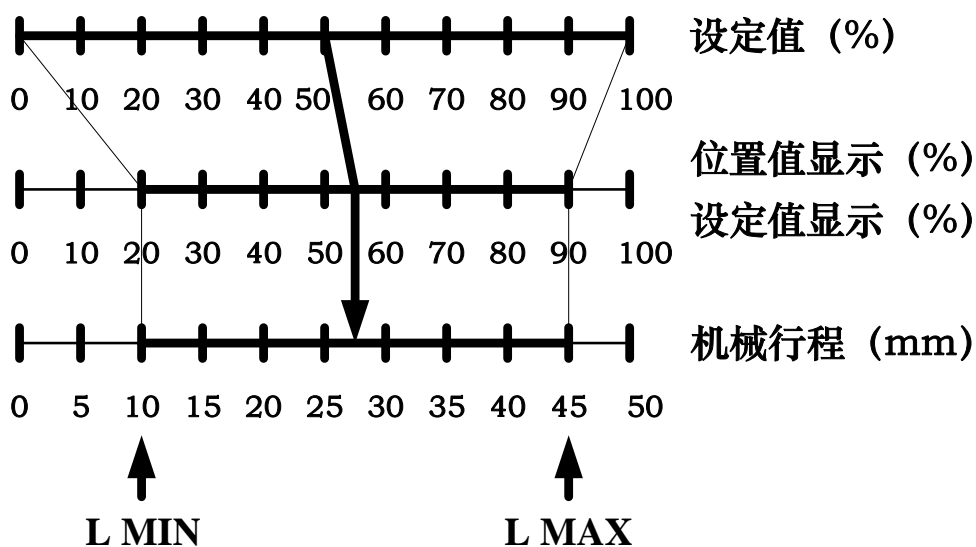

图55. 示例: POS = LS, L MIN = 20%, L MAX = 90%

8.3.2.12.SAFE

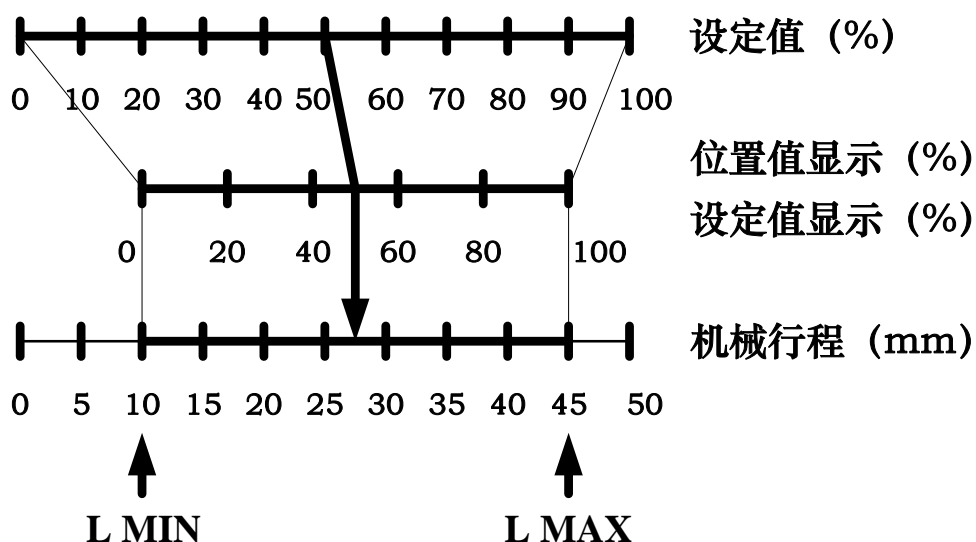
此功能用于在自动模式下，当通信失败或主机发送错误 SP 状态值时，将阀位移动到定义的安全位置。





菜单界面选择此功能，按  键开启参数设置，参数闪烁显示。按  键设置参数。按  键确认修改。

设置参数选项

选项	描述
ACT	使阀位处于设备断电状态下的位置。
LPOS	使用上一个有效的设定值来控制阀位。
SPOS	使用配置的安全设定值来控制阀位。





8.3.2.13.STIM

此功能用于设置阀位切换到安全位置的等待时间。单位为秒。当系统判断到切换到安全位置的条件时，计时到达设置的等待时间后使能安全位置。

菜单界面选择此功能，按  键开启参数设置，参数闪烁显示。按  键设置参数。按  键确认修改。

8.3.2.14.SPOS

此功能用于设置 SAFE 选项中参数 SPOS 的值。

菜单界面选择此功能，按  键开启参数设置，参数闪烁显示。按  键设置参数。按  键确认修改。



8.3.2.15.FACT

大部分菜单参数恢复到出厂设置。

菜单中选择此功能，长按  键 3 秒左右恢复出厂设置。恢复出厂设置后，系统处于未初始化状态，LCD 显示 FINSH。

8.3.2.16.SADDR

此功能用于设置从站地址。

菜单界面选择此功能，按  键开启参数设置，参数闪烁显示。按  键设置参数。

按 键确认修改。

当定位器在进行正常的周期性数据通信时，此参数无法更改。当操作 FACT 功能后，此参数不恢复为默认值。

8.3.2.17.WP

此功能为参数写保护功能。参数 **oFF** 为写保护关闭，参数 **on** 为写保护开启。

菜单界面选择此功能，按 键开启参数设置，参数闪烁显示。按 键设置参数。按 键确认修改。

当写保护开启后，菜单选项 1-16，选项 20 中的 S/W，以及一键初始化功能无法操作。

8.3.2.18.ACT

作用方式选择。厂家内部使用。无特殊情况不建议用户操作此选项。

8.3.2.19.REF

直行程反馈杆参考点标定。厂家内部使用。无特殊情况不建议用户操作此选项。



8.3.2.20.REC

定位器运行数据记录。

记录数据选项

选项	描述
HOURS	运行小时数。定位器上电后开始记录。
P CNT	正向偏差次数。在自动模式下，当定位器处于定位状态时，将基于初始化后的机械行程对应的位置值与位置设定值做比较。如果设定值大于位置值，且两者偏差超过死区值+10%并持续超过 1 分钟，累计计数 1 次。
N CNT	负向偏差次数。在自动模式下，当定位器处于定位状态时，将基于初始化后的机械行程对应的位置值与位置设定值做比较。如果位置值大于设定值，且两者偏差超过死区值+10%并持续超过 1 分钟，累计计数 1 次。
CLR	清空 HOURS, P CNT, N CNT 记录。REC 子菜单中选择此功能，长按 <input type="checkbox"/> 键 3 秒左右开始运行。记录清空后，LCD 上显示 FINSH 。
S/W	开启或关闭数据记录。参数 oFF 为关闭，参数 on 为开启。

8.3.3. 初始化过程错误提示

提示标志	提示说明	推测原因	处理方法
ERR 1	执行器动作错误	<ul style="list-style-type: none"> ● 无气源压力或气源压力不够。 ● 定位器或阀门存在漏气。 	<ul style="list-style-type: none"> ● 检查气源和气源压力，确保供气正常。 ● 消除漏气问题。
ERR 2	对于非分体式定位器，反馈杆或转动轴的转动角度错误。对于分体式定位器，匹配的阀门行程不满足要求。	<ul style="list-style-type: none"> ● 非分体式定位器安装不到位。致使执行器反馈杆或转动轴的转动角度不满足安装要求。 ● 手动初始化时，手动标定的 END 1 和 END 2 两个行程端点的差值不满足要求。 	<ul style="list-style-type: none"> ● 对于非分体式定位器，在初始界面 (NOINI) 下，通过 LCD 上显示的角度传感器百分比值调整安装位置，使角度传感器转动最小最大百分比差值大于 16%。 ● 如果是在手动初始化操作过程，则通过操作   键重新标定 END 1 和 END 2,使两个行程端点间的传感器百分比差值大于 16% (非分体式) 或 8% (分体式)。
ERR 3	传感器行程最小值错误。	定位器安装不到位。	对于非分体式定位器，在初始界面 (NOINI) 下，通过 LCD 上显示的传感器百分比值调整安装位置。使传感器百分比最小值 $\geq 5\%$ 。对于分体式定位器，重新调节 D 值。使传感器百分比最小值 $\geq 12\%$ (ELin1) 或 2% (ELin2)。
ERR 4	传感器行程最大值错误。	定位器安装不到位。	对于非分体式定位器，在初始界面 (NOINI) 下，通过 LCD

			上显示的传感器百分比值调整安装位置。使传感器百分比最大值 $\leq 95\%$ 。对于分体式定位器，重新调节 D 值。使传感器百分比最大值 $\leq 92\%$ (ELin1) 或 97% (ELin2)。
--	--	--	--

8.3.4. 菜单选项或功能无法访问提示

当设置菜单选项参数或运行初始化时可能会出现如下标志来提示无法访问。具体说明见下表。

提示标志	提示说明
P1	写保护开启。
P2	直行程反馈杆参考点未标定，无法对直行程执行机构进行初始化操作。

8.3.5. 菜单功能选项汇总说明

选项	功能	参数值	出厂设置
1 TYPE	执行机构类型设置	Lin Turn FLin ELin1 ELin2	Lin
2 INITA	自动初始化		
3 INITM	手动初始化		
4 SDIR	设定值方向设置	riSE FALL	riSE
5 CHAR	特性曲线选择	Lin 1:25 1:33 1:50 n1:25 n1:33 n1:50 FrEE	Lin
6 FREE→FR 0, FR 5...FR100	自定义参数设置	0.0% – 100.0%	0.0% 5.0% etc. to 100.0%
7 DB	死区设置	0.2 – 10.0%	1.0%
8 LIM→L MIN	行程限制功能最小值设置	0.0% – 100.0%	0.0%
8 LIM→L MAX	行程限制功能最大值设置	0.0% – 100.0%	100.0%

9 YDIR	位置值显示和设定值显示的动作方向设置	riSE FALL	riSE
10 CUT→C MIN	紧闭功能最小值设置	0.0% – 100.0%	1.0%
10 CUT→C MAX	紧闭功能最大值设置	0.0% – 100.0%	100.0%
11 POS	位置值显示的标准设置	FS LS	FS
12 SAFE	安全位置设置	ACT LPOS SPOS	ACT
13 STIM	安全位置等待时间设置	0-100s	0s
14 SPOS	安全设定值设置	0.0% – 100.0%	0.0%
15 FACT	恢复出厂设置		
16 SADDR	从站地址设置	0-126	126
17 WP	写保护	oFF on	oFF
18 ACT	作用方式选择		
19 REF	直行程反馈杆参考点标定		
20 REC→HOURS	运行小时数	0-876000	0
20 REC→P CNT	正向偏差次数	0-99999	0
20 REC→N CNT	负向偏差次数	0-99999	0
20 REC→CLR	清空数据记录		
20 REC→S/W	开启或关闭数据记录	oFF on	on

8.4. PROFIBUS PA 功能和操作

8.4.1. 从站地址设置

控制系统（主站）与定位器（从站）要实现周期性和非周期性的数据传输，需要先设置定位器的从站地址。可在设备菜单选项中设置从站地址，也可以使用 SIMATIC PDM V6.0 软件通过总线来设置从站地址。从站地址出厂设置为 126。

8.4.2. 周期性数据传输

周期性数据传输用于在 1 类主站与定位器之间传输过程自动化相关的参数。

8.4.2.1. 组态

将厂商提供的 GSD 文件导入到西门子 STEP7 软件中。在 STEP7 上建立工程，使用组态工具 HW config 进行组态。

8.4.2.2. 数据定义

名称	传输方向 (对于定位器)	字节长度	描述
SP	输入	5 (值/状态)	设定值, 包含 4 个字节的浮点数值和 1 个字节的狀態。
READBACK	输出	5 (值/状态)	反馈值, 包含 4 个字节的浮点数值和 1 个字节的狀態。数值对应定位器屏幕上显示的阀位值或传感器信号值。
POS_D	输出	2 (值/状态)	离散阀门位置值, 包含 1 个字节的数值和 1 个字节的狀態。
CHECKBACK	输出	3 (值)	以位编码的格式指示定位器的一些运行状态。

POS_D

值	含义
0	未初始化。
1	阀门关闭。阀位值 $\leq 1\%$ 。
2	阀门打开。阀位值 $\geq 99\%$ 。
3	阀门在中间位置。 $1\% < \text{阀位值} < 99\%$ 。

CHECKBACK

字节	位	“1”的定义
0	0	定位器处于故障安全位置。
	1	保留。
	2	在菜单界面配置参数或运行一键初始化。
	3	在手动模式或未初始化界面 (NOINI)。
	4~7	保留。

1	0	定位器正在做打开阀门动作。
	1	定位器正在做关闭阀门动作。
	2	如果在菜单里修改了功能选项 1, 4~14 中的参数或运行了功能选项 15, 从菜单退出后将临时置位。
	3~7	保留。
2	0~7	保留。

8.4.2.3. 数据组合

主站与定位器之间的周期性数据传输包含以下 4 种数据组合，用户可根据实际需求选择适合的数据组合形式。

组合 1: SP

输出 (主站)		
起始地址	0	SP 浮点数
	1	
	2	
	3	
	4	SP 状态

组合 2: READBACK + POS_D, SP

输入 (主站)		
起始地址	0	READBACK 浮点数
	1	
	2	
	3	
	4	READBACK 状态
	5	POS_D
	6	POS_D 状态

输出 (主站)		
起始地址	0	SP 浮点数
	1	
	2	
	3	
	4	SP 状态

组合 3: CHECKBACK, SP

输入 (主站)		
起始地址	0	CHECKBACK
	1	
	2	

输出 (主站)		
起始地址	0	SP 浮点数
	1	
	2	
	3	
	4	SP 状态

组合 4: READBACK + POS_D + CHECKBACK, SP (默认)

输入 (主站)		
起始地址	0	READBACK 浮点数
	1	
	2	
	3	
	4	READBACK 状态
	5	POS_D
	6	POS_D 状态
	7	CHECKBACK
	8	
9		

输出 (主站)		
起始地址	0	SP 浮点数
	1	
	2	
	3	
	4	SP 状态

8.4.3. 非周期性数据传输

非周期性数据传输主要用于现场调试和维护期间,2类主站和定位器之间进行的数据传输。主站通过SIMATIC PDM V6.0软件与定位器进行非周期性数据传输。

8.4.3.1. SIMATIC PDM V6.0 操作步骤

1. 使用 SIMATIC PDM V6.0 中的 **Manage device catalog** 工具导入设备 EDD 文件。
2. 打开 SIMATIC PDM V6.0 中的 **LifeList** 工具。当 **LifeList** 扫描到设备后,在设备栏双击对应的设备后弹出如下界面:

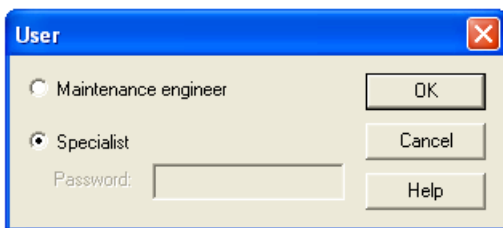

选择 **Specialist** 选项, 点击 **OK**。

3. PDM 操作界面被打开。如下图所示。

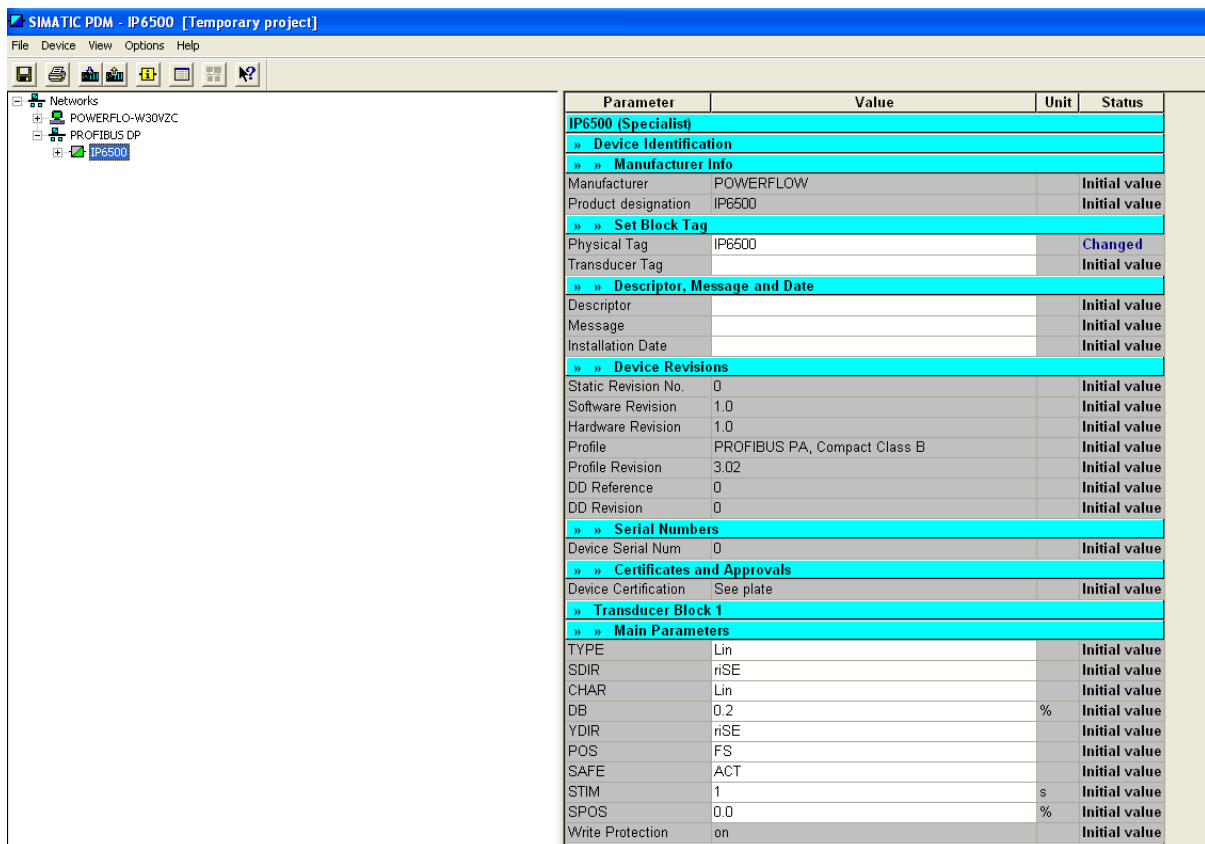

4. 点击  按钮进行数据上传。界面右侧参数栏将显示读取到的设备相关参数。显示的参数对应绝大部分设备菜单参数。

5. 可对界面右侧参数栏中的参数进行修改。修改后，点击  按钮将修改的数据下载到设备中。

注意：

- 使用 SIMATIC PDM V6.0 进行数据传输时，请不要对定位器进行本地操作，且定位器显示界面不要停留在菜单界面。如果在运行初始化功能或在菜单界面下下载参数，定位器将不会更新下载的参数直到退出初始化或退出菜单界面一段时间。
- 修改并下载参数前必须进行数据上传操作。

8.4.3.2. 通过 SIMATIC PDM V6.0 设置从站地址

在 PDM “Device” 菜单中选择 **Set Address** 选项进行从站地址设置。如果从站地址被修改，需要关闭 PDM 操作界面，通过 LifeList 重新扫描连接设备。

8.4.3.3. 通过 SIMATIC PDM V6.0 执行 FACT 和 CLR 功能

PDM “Device” 菜单中的 **FACT** 和 **CLR** 选项功能对应定位器菜单中的 **FACT** 和 **CLR** 选项。用于使定位器恢复出厂设置和清除 REC 选项的数据记录。如有需要，选择相关选项执行相应功能。

8.5. 流量调节

1. 取下电路板保护盖



图56. 拆除电路板保护盖

注意：请在设备断电情况下拆装电路板保护盖。

2. 调整节流杆位置

- 对于小型执行机构而言，节流杆可减少空气输出，增加定位稳定性。为此，可使用节流杆 Y1①和 Y2②。
- 使用一字螺丝刀顺时针转动节流杆，可减少空气输出直至最终切断输出。
- 设置节流杆时，建议先将其关闭，然后再缓慢打开。
- 双作用阀的情况下，确保两个节流杆的设置位置相仿。

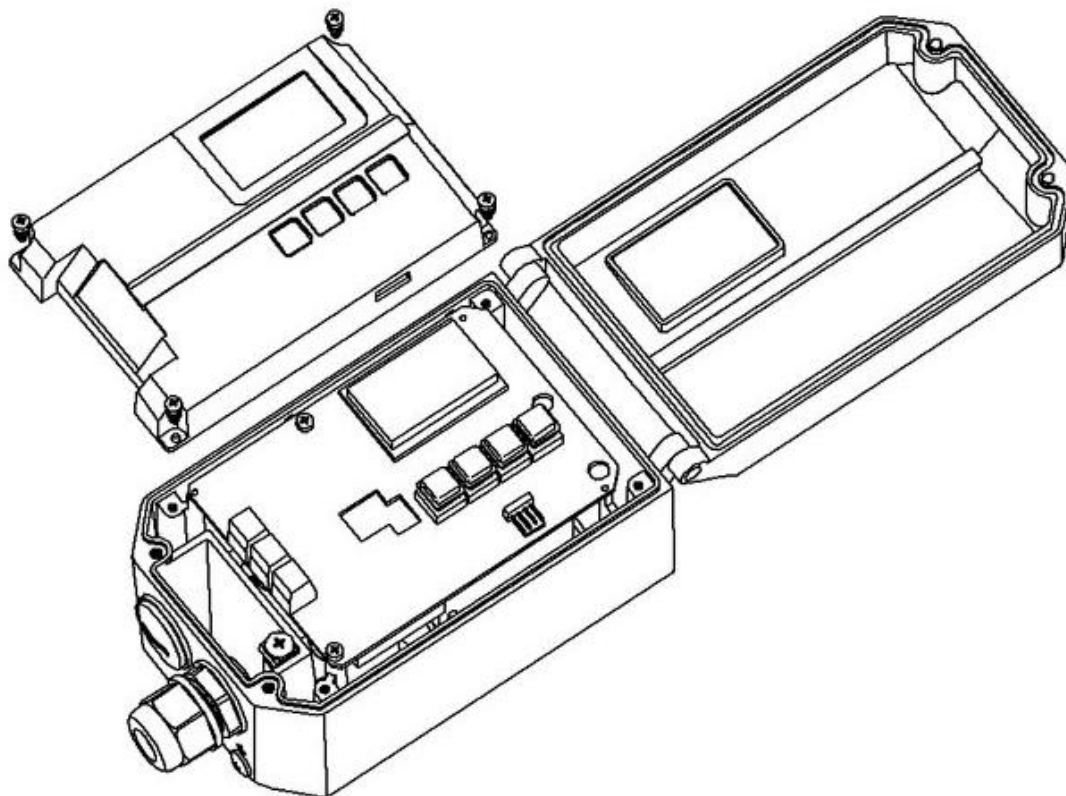

图57. 流量调节

- ① 节流杆 Y1
② 节流杆 Y2, 仅适用于双作用执行机构版本。

9. 故障检修

内容	推测原因	处理方法
LCD 无显示。	电气接口连接错误。	请确认定位器的电气连接。
	电源故障。	检查电源是否正常。
	使用超出规格范围的电源。	请使用符合规格范围的电源。
	其他。	请向本公司询问。
LCD 上显示标志 F。	通信失败。	检查从机地址是否正确。
	主站发送错误的 SP 状态值。	设置发送的 SP 状态值为 0x80。
OUT1 或 OUT2 口无空气输出 (完全没有动作)。	供气压力不正常。	请确认供气压力减压阀的设定。
	配管漏气。	请确认配管及管头, 阻止泄露。
	其他。	请向本公司询问。
精度不好 (线性、滞后现象)。	供气压发生变动。	请确认供气压力减压阀是否有异常。
	定位器安装螺栓松动。	请确认定位器的安全螺栓紧固。
	定位器和执行器的连接部有间隙。	请确认定位器的连接方式。
	其他。	请向本公司询问。

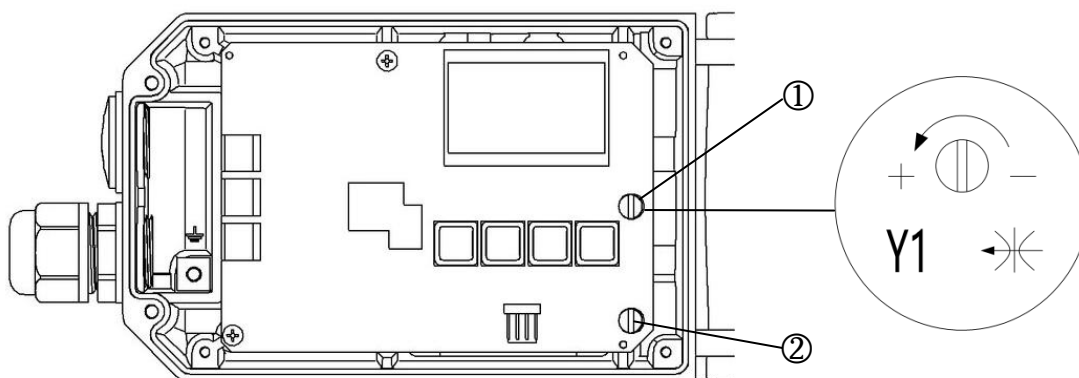
10. 保修条款

- 发现产品有质量问题, 经我公司人员确认后, 客户享有在质保期内免费更换或维修的售后服务。服务响应时间为 24 小时 (非工作日除外)。
- 产品的质保期以本公司最新质保政策为准, 不低于售出后 12 个月。
- 如下情况的返修品, 不属质保范围:
 - (1) 超过质保期的产品。

- (2) 未经我公司授权和允许，私自拆装过的产品。
 - (3) 未按产品使用说明书操作或其他人为因素造成的产品损坏，包括但不限于：
 - 1> 产品表面有碰撞伤痕。
 - 2> 接线或供电错误造成元器件损坏。
 - 3> 零部件或配件丢失。
 - 4> 未加装过滤减压器或油雾分离器导致油污进入产品内部造成元器件损坏。
 - 5> 未按使用规范使用防水电气接头导致产品损坏。
 - (4) 不可抗拒因素（自然灾害）造成产品故障或损毁。
4. 不属于产品质保范围的维修，我公司将视实际情况提供免费或收费维修服务。
5. 本条款自双方签定供货合同时生效。

Contents

1. Overview	64
2. One-key automatic initialization	64
3. Selection and ordering data	66
4. Technical data	67
5. Connection description	68
6. Dimension	69
6.1. Mechanical dimension	69
6.2. Mounting bracket dimension	70
6.3. Dimension of linear stroke feedback lever	74
6.3.1. Feedback lever A (with driving pin)	74
6.3.2. Feedback lever B (without driving pin)	74
6.4. Sensor dimension for separate type	75
6.5. Sensor dimension for remote type	76
7. Installation	77
7.1. Linear stroke (normal type or remote type)	77
7.1.1. Installation of general piping connections	77
7.1.2. Installation of no piping connections	88
7.2. Rotary stroke (normal type or remote type)	89
7.3. Separate type	96
8. Operation	100
8.1. Interface description	100
8.2. Display and operation of main interface	101
8.3. Menu and functions	103
8.3.1. Display and operation of menu	103
8.3.2. Functions description and operation	103
8.3.2.1. TYPE	103
8.3.2.2. INITA	103
8.3.2.3. INITM	104
8.3.2.4. SDIR	104
8.3.2.5. CHAR	105
8.3.2.6. FREE	106
8.3.2.7. DB	107
8.3.2.8. LIM	108
8.3.2.9. YDIR	108
8.3.2.10. CUT	109
8.3.2.11. POS	109
8.3.2.12. SAFE	110
8.3.2.13. STIM	111

8.3.2.14.	SPOS	111
8.3.2.15.	FACT.....	111
8.3.2.16.	SADDR	111
8.3.2.17.	WP.....	111
8.3.2.18.	ACT.....	112
8.3.2.19.	REF	112
8.3.2.20.	REC	112
8.3.3.	Error message during initialization.....	113
8.3.4.	Tips of menu option or function cannot access.....	114
8.3.5.	Menu function options summary description.....	114
8.4.	PROFIBUS PA functions and operation	115
8.4.1.	Slave address setting	115
8.4.2.	Periodic data transmission	116
8.4.2.1.	Configuration	116
8.4.2.2.	Data definition.....	116
8.4.2.3.	Data combination	117
8.4.3.	Non-periodic data transmission	119
8.4.3.1.	SIMATIC PDM V6.0 operation steps.....	119
8.4.3.2.	Slave address setting via SIMATIC PDM V6.0	120
8.4.3.3.	FACT and CLR functions via SIMATIC PDM V6.0	120
8.5.	Adjust air flow	120
9.	Trouble shooting	122
10.	Warranty terms.....	122



1. Overview

IP6500 series intelligent valve positioner is used in conjunction with pneumatic actuator. The positioner receives the set-point value from the control system via the PROFIBUS PA bus and collects the position sensor signal to obtain the actual valve value. Through the calculation and processing of the control software, the inlet and exhaust air of the pneumatic actuator are controlled, so as to drive the valve position to the set point.

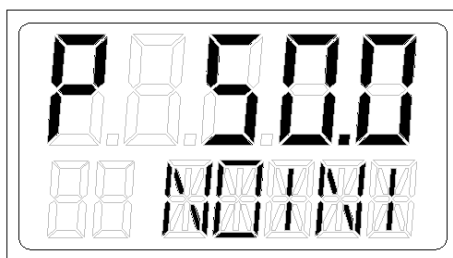

2. One-key automatic initialization

1. Please read the installation instructions in **chapter 7** before installing the positioner. Install the positioner according to the installation requirements described. Please pay attention to some installation points. For example, confirm the initial position of the feedback axis of the positioner or remote sensor before installation. Do not turn the feedback axis 360° during installation. For the positioner of normal linear type, make the upper plane of the positioner housing at a right angle to the main stem of the valve. Within the valve stroke range, the rotation angle of the positioner feedback lever meets the installation requirements.
2. After installing the positioner on the valve, connect the air source and electrical cables. Ensure that the air source pressure can fully open the valve. Power on the positioner by the output voltage signal of the DP/PA coupler.
3. After the positioner is powered on, positioner is in the uninitialized state before initialization. When LCD displays the sign **NOINI**, interface displays percentage value of sensor in the top line. As shown below.



In this state, pressing   buttons can open and close valve. Open and close valve fully, and observe the percentage value of sensor displayed on the interface. For non-separate type, ensure that within the entire valve stroke range, the minimum sensor percentage value $\geq 5\%$, and the maximum sensor percentage value $\leq 95\%$. Otherwise, it is necessary to re-adjust the installation position to make the linear stroke feedback lever or the angle stroke adapter move within the effective range. For separate type, ensure that within the valve stroke range of 5-25mm, the minimum sensor percentage value $\geq 12\%$, and the maximum sensor percentage value $\leq 92\%$; within the valve stroke range of 25-50mm, the minimum sensor percentage value $\geq 2\%$, and the maximum sensor percentage value $\leq 97\%$. Otherwise, the D value of the sensor

needs to be adjusted. In addition, the minimum and maximum percentage difference of the sensor is required to be greater than 16% (non-separate type) or 8% (separate type).

4. The actuator type has been set before the positioner leaves the factory. The user only needs one-key operation to execute the automatic initialization (**INITA**) function to complete the matching of the valve. In the initial interface (**NOINI**) or manual / automatic mode interface, press and hold  button for approx. 3s to run the automatic initialization. After the initialization is completed, **FINSH** is displayed on the LCD, press  button to exit. After exiting, the system enters the manual mode interface, press  button again to switch to the automatic mode. For some reasons, the system will display an error message in the function option line during the automatic initialization process and the automatic initialization will be interrupted. Descriptions of error messages and solutions are showed in chapter 8.3.3.

3. Selection and ordering data

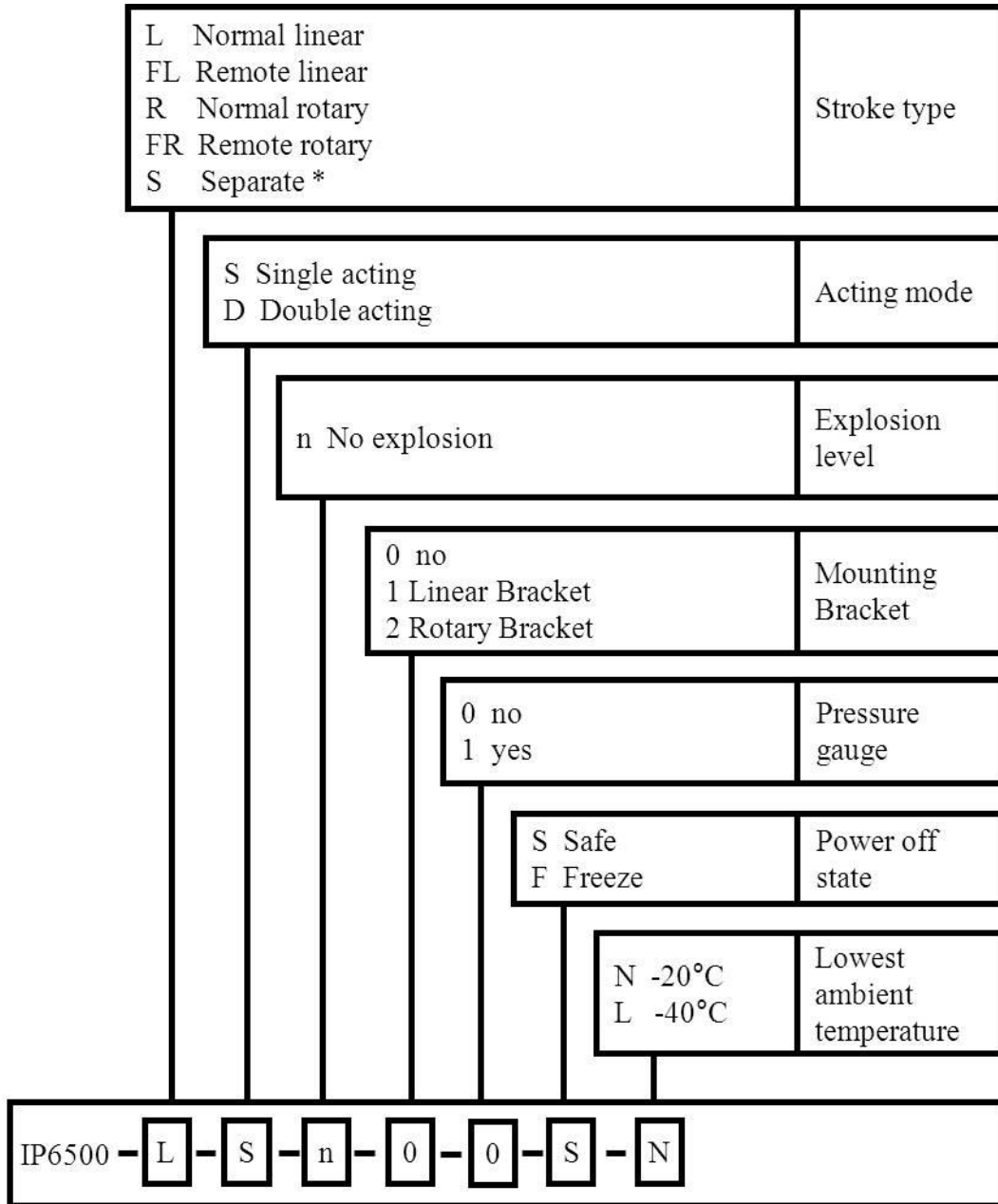

Remarks:

In **Stroke type** options, the option **S**(Separate) marked with * does not support **Lowest ambient temperature** option **L**(-40°C).

4. Technical data

Shell material	Aluminum
Power supply and signal transmission	DP/PA coupler
Intrinsically safe power supply	17.5V DC
Operating voltage range	9~32V DC
Ambient temperature	Normal version for non-explosion-proof: -20°C ~ +80°C Optional version for non-explosion-proof: -40°C ~ +80°C The device display will be dull or not displayed below -20°C.
Gas source requirement	ISO 8573-1 <ul style="list-style-type: none"> ● Solid particle size and density Class 3 ● Dew point Class 3 ● Oil content Class 3
Vibration resistance	0.15mm,10Hz-60Hz,20 cycle/axis 20m/ s ² ,60Hz-500Hz,20 cycle/axis Recommended range for control valve ≤ 20 m/s ² , no resonance peak
Supply pressure	0.14~0.7MPa
Flow	<ul style="list-style-type: none"> ● Input air 2 bar 4.8 Nm³/h 4 bar 8.0 Nm³/h 6 bar 11.2 Nm³/h ● Exhaust air(Safe) 2 bar 5.9 Nm³/h 4 bar 9.8 Nm³/h 6 bar 13.7 Nm³/h ● Exhaust air (Freeze) 2 bar 6.6 Nm³/h 4 bar 11.1 Nm³/h 6 bar 15.6 Nm³/h
Steady state air consumption	≤0.4 L/min
Basic error	≤1.0%
Hysteresis error	≤1.0%
Electrical connection	1/2NPT (default) or M20x1.5, please contact with sales for other thread specifications
Pneumatic connection	1/4NPT (default) or G1/4, please contact sales for other thread specifications

Weight	2.0 kg
Protection class	IP67

5. Connection description

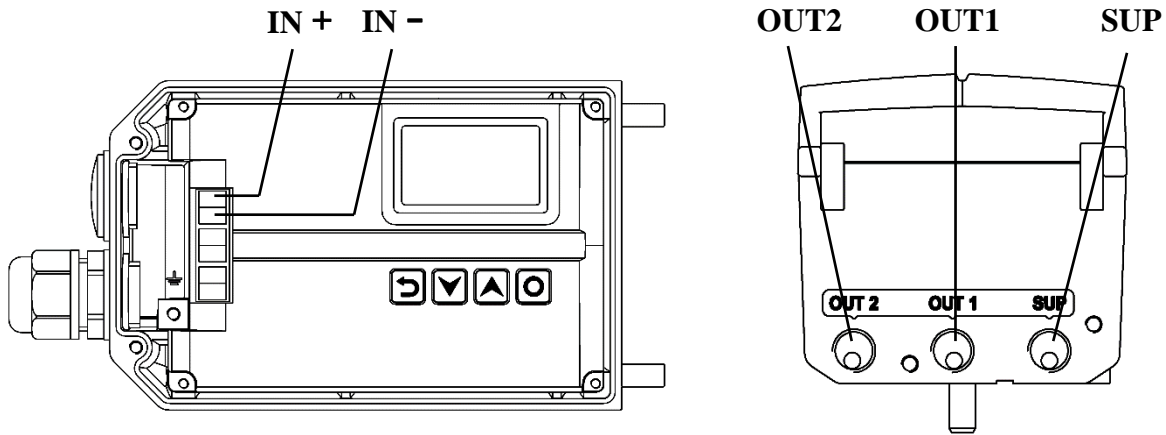

Figure 1. Connection description

Electrical Connection	Description
IN+	Bus signal +
IN-	Bus signal -

Pneumatic Connection	Description
SUP	Air supply enter
OUT1	Pilot air outlet 1
OUT2	Pilot air outlet 2, used for double acting type.

Remarks: For the separate type of the positioner, OUT1 and OUT2 are blocked and not used.

NOTES :

- Fully shielded, multi-pair twisted pair cables are highly recommended. Connect one end of the cable shielding layer to the \perp screw inside the casing, and the other end to the ground. So that the device is effectively grounded to prevent electromagnetic interference.
- Keep electrical cables away from strong magnetic fields.
- Must install or remove the electrical cable when the device is powered off.
- If the device is used in an intrinsically safe explosion-proof environment, electrical cables must be used that meet the intrinsically safe explosion-proof level of the device.

6. Dimension

6.1. Mechanical dimension

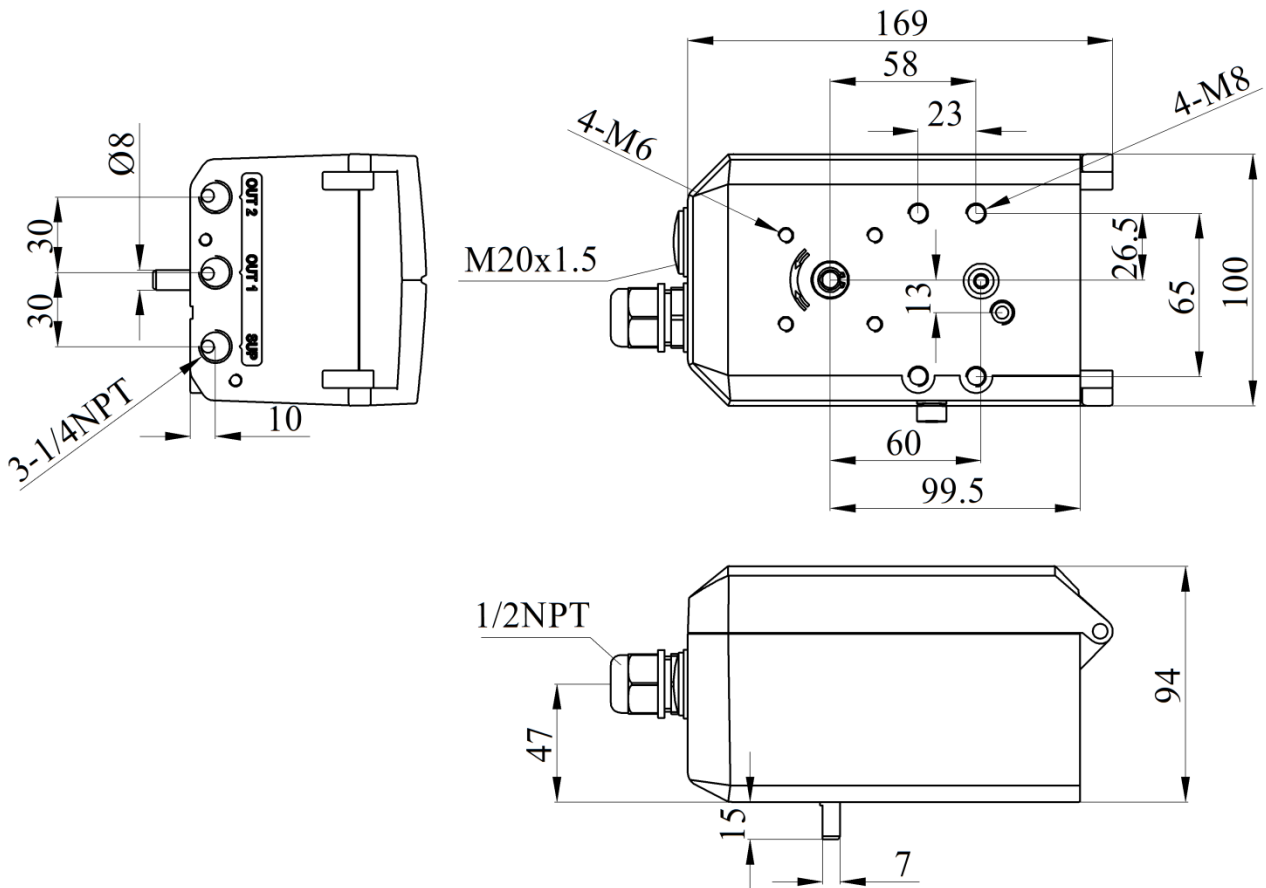

Figure 2. Mechanical dimension

6.2. Mounting bracket dimension

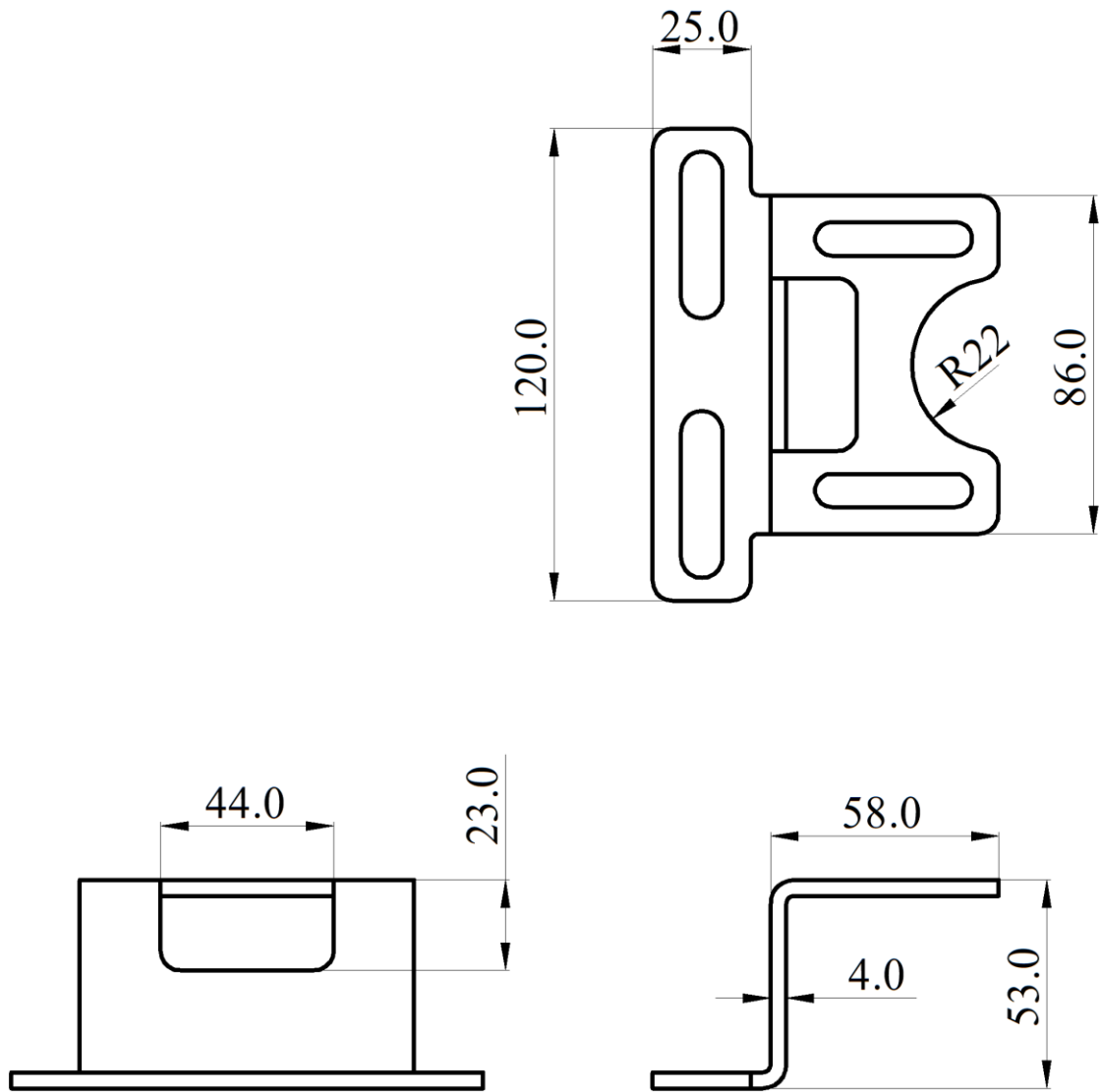

Figure 3. Normal linear mounting bracket

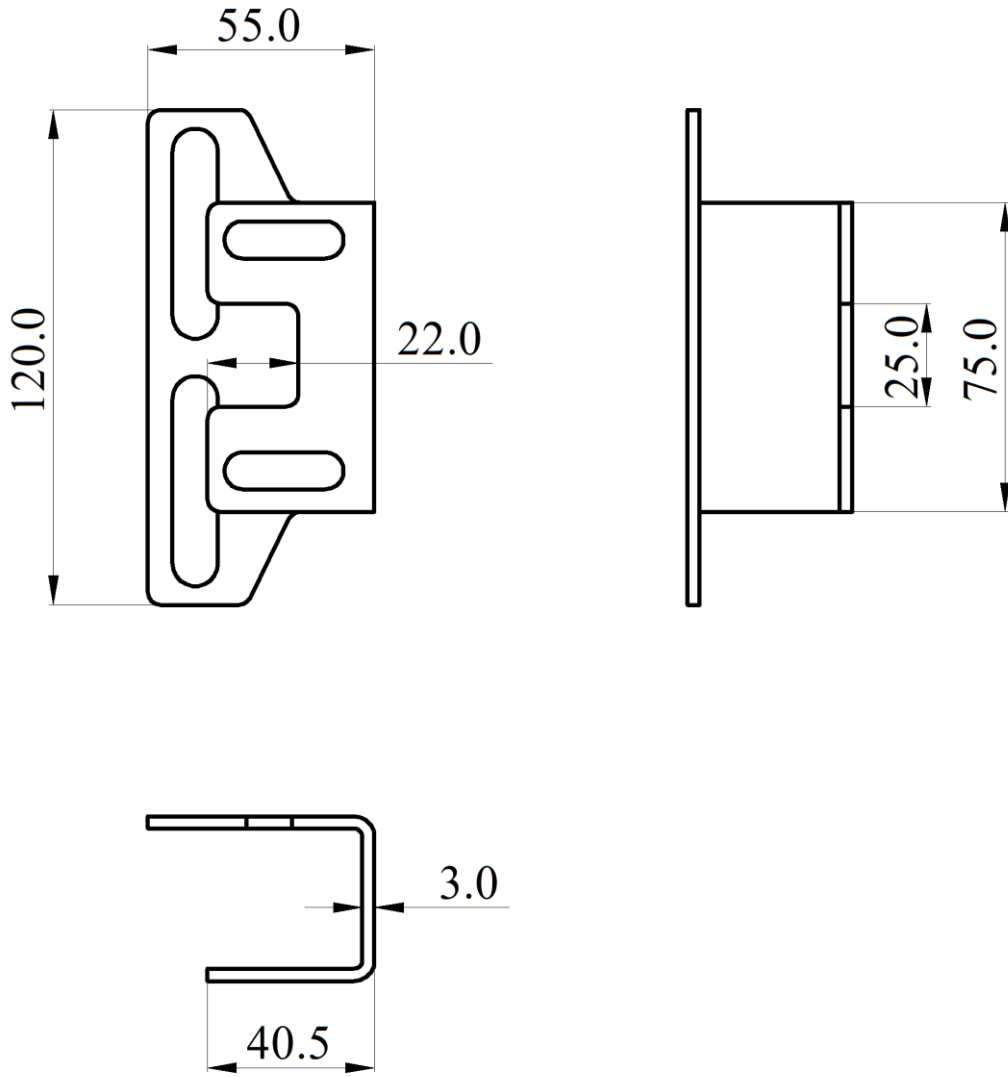

Figure 4. Remote linear mounting bracket

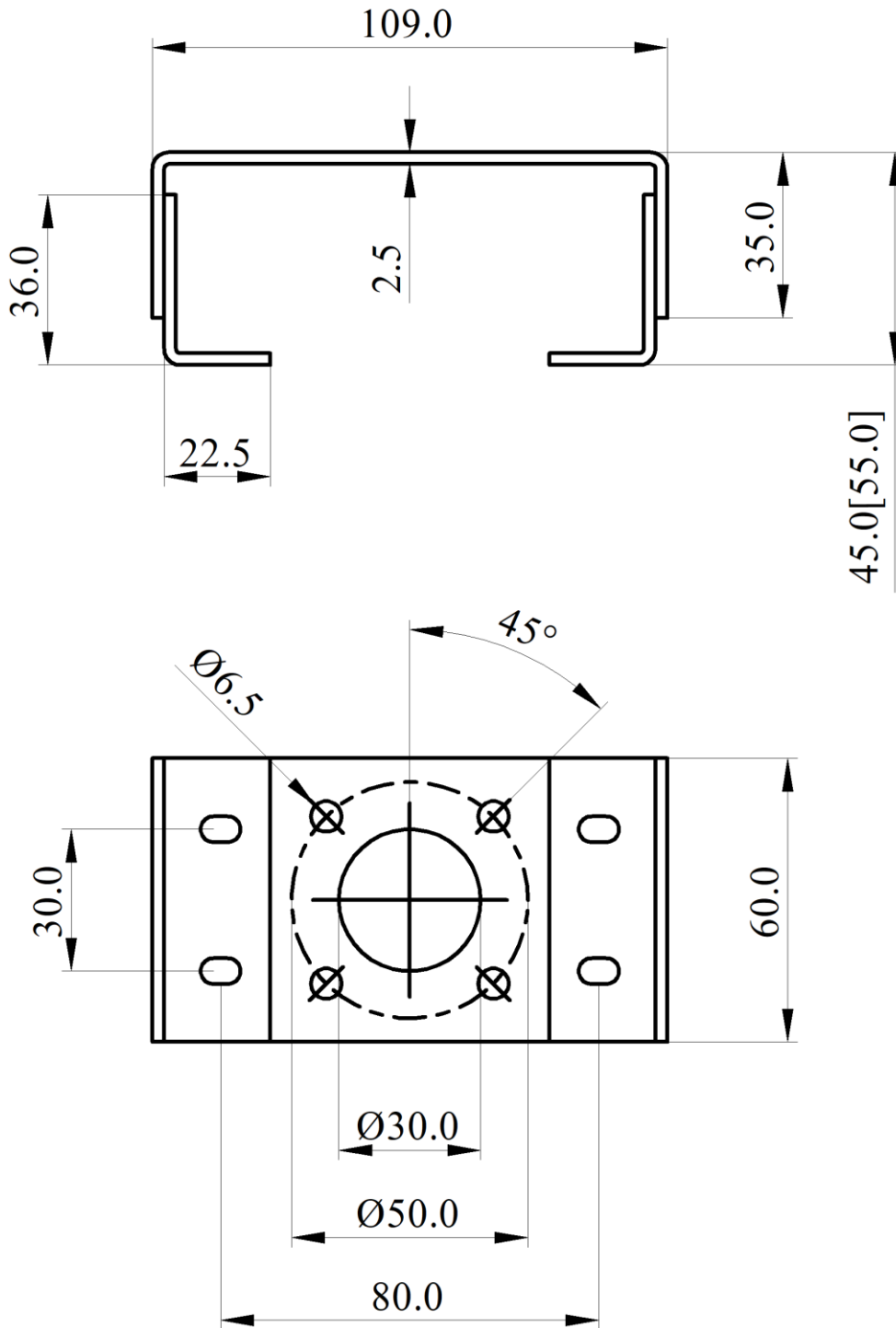

Figure 5. Rotary mounting bracket (Type A)

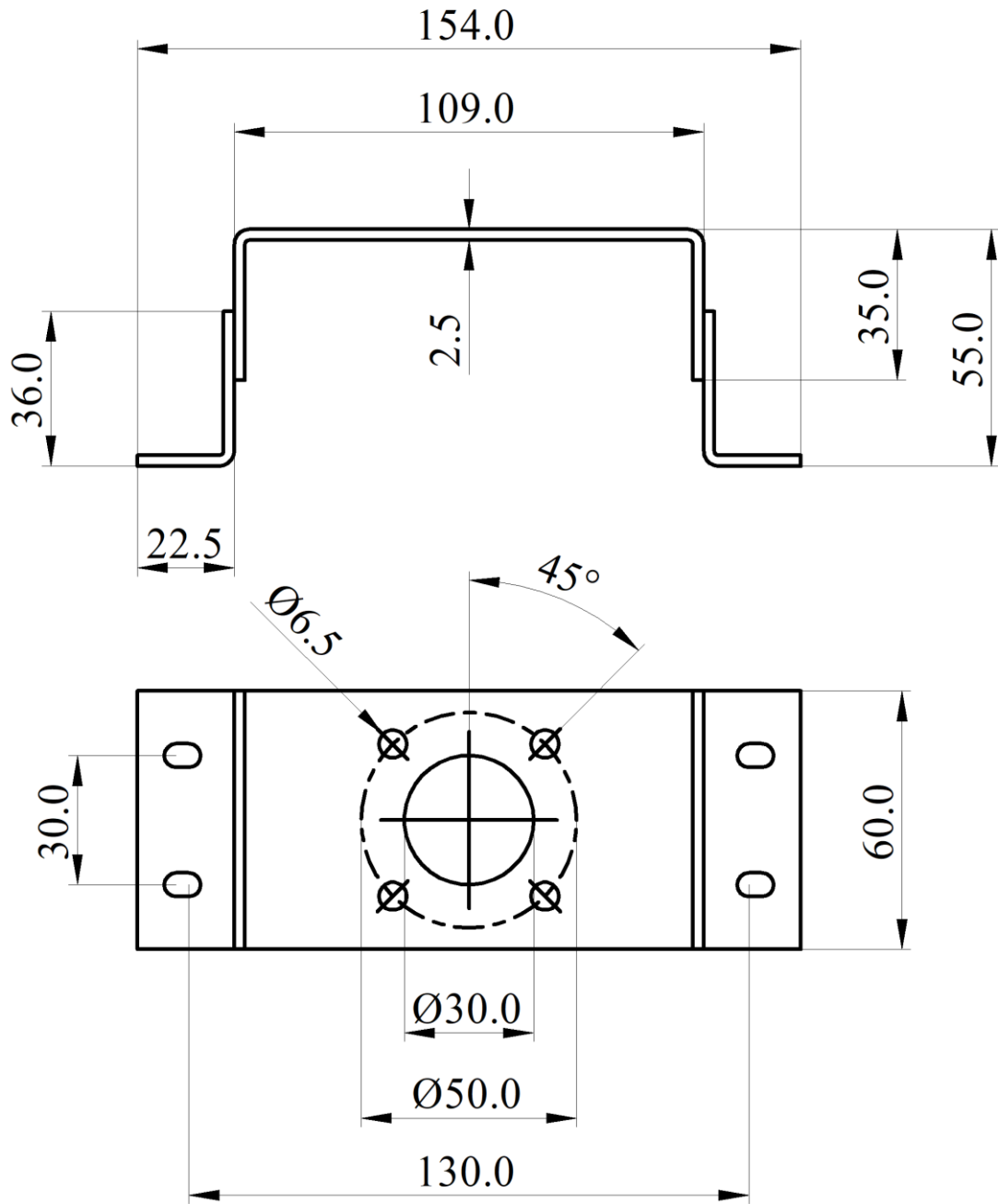

Figure 6. Rotary mounting bracket (Type B)

6.3. Dimension of linear stroke feedback lever

6.3.1. Feedback lever A (with driving pin)

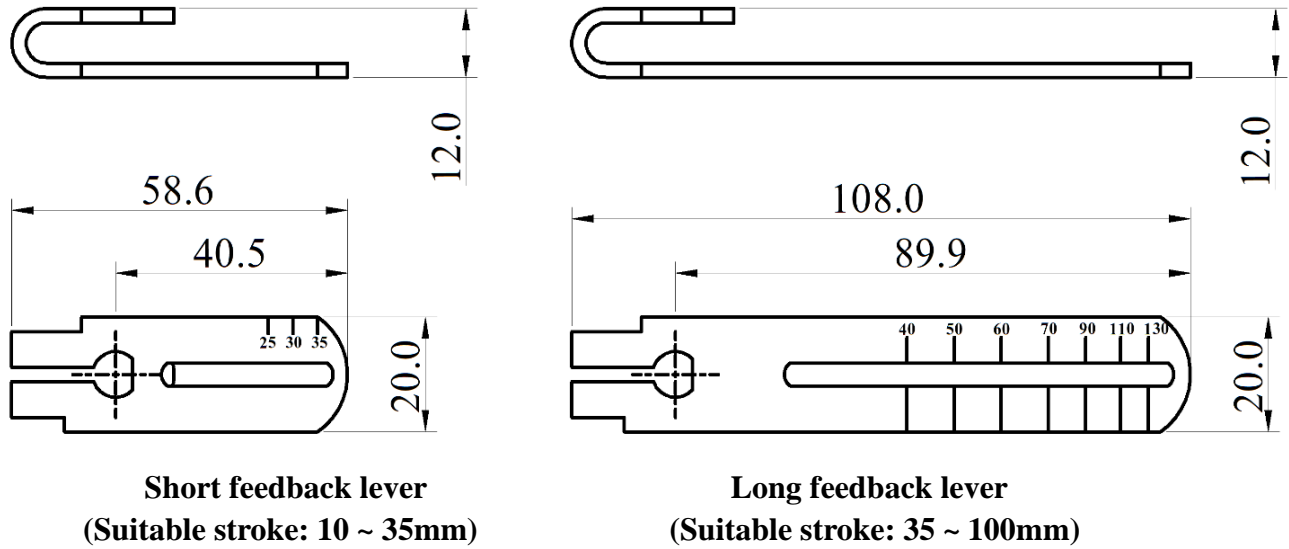

Figure 7. Dimension of feedback lever A

6.3.2. Feedback lever B (without driving pin)

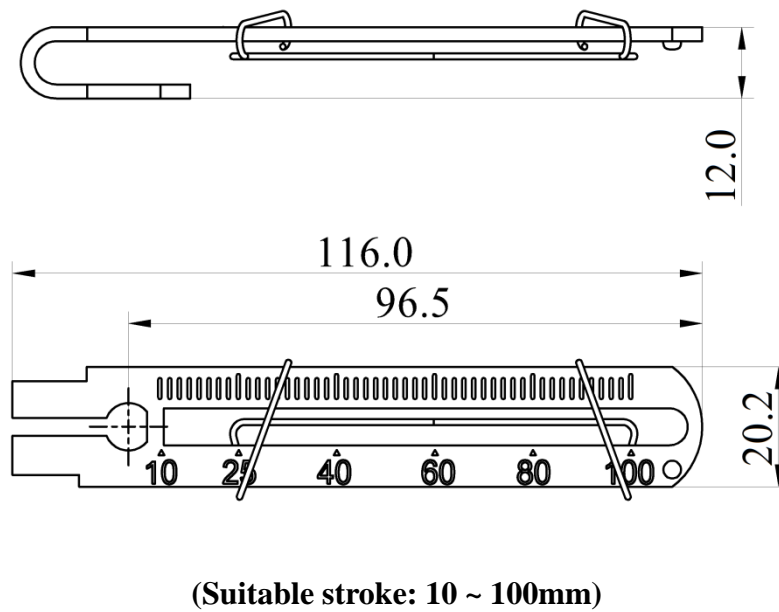

Figure 8. Dimension of feedback lever B

6.4. Sensor dimension for separate type

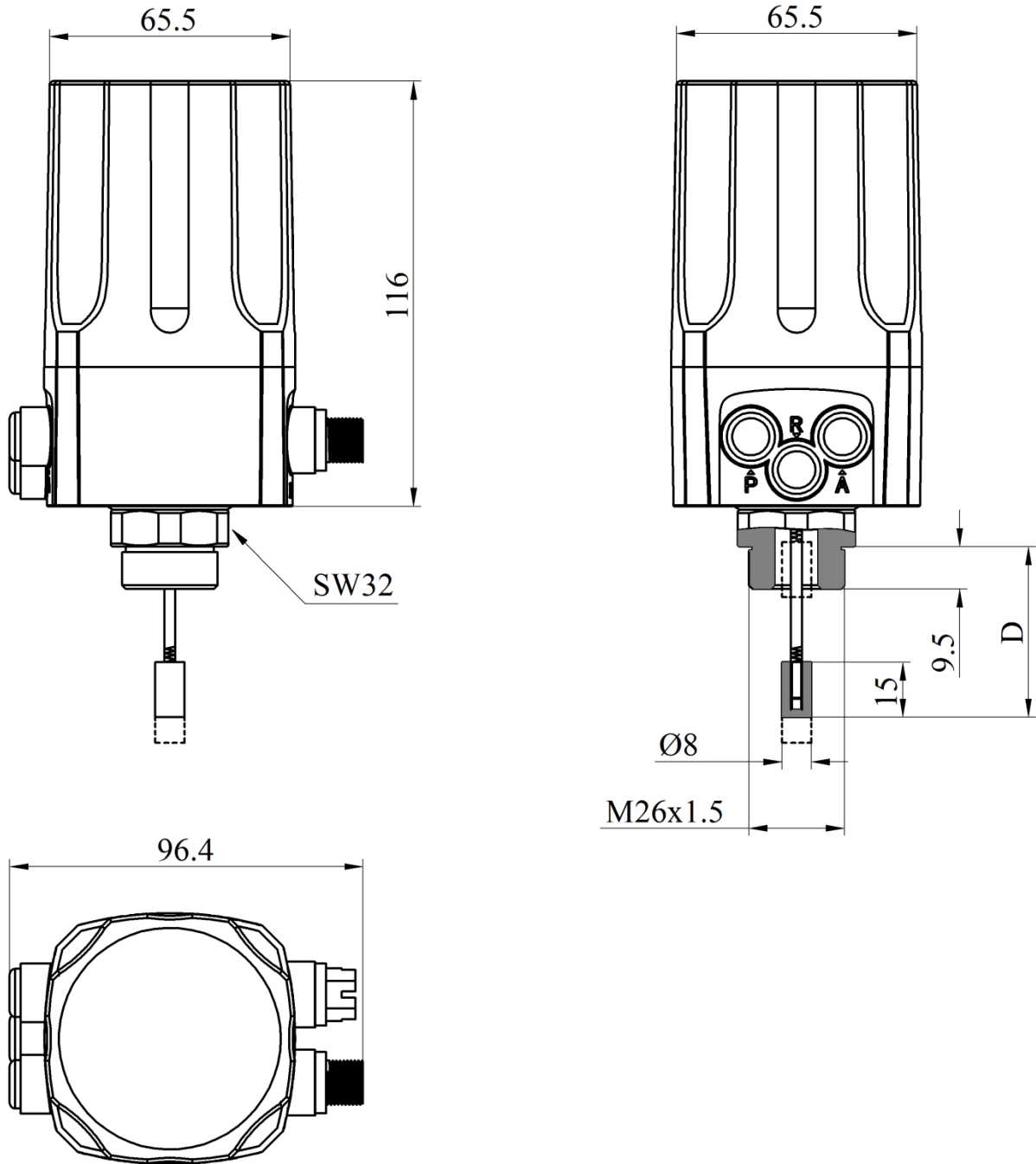

Figure 9. Sensor dimension for separate type

6.5. Sensor dimension for remote type

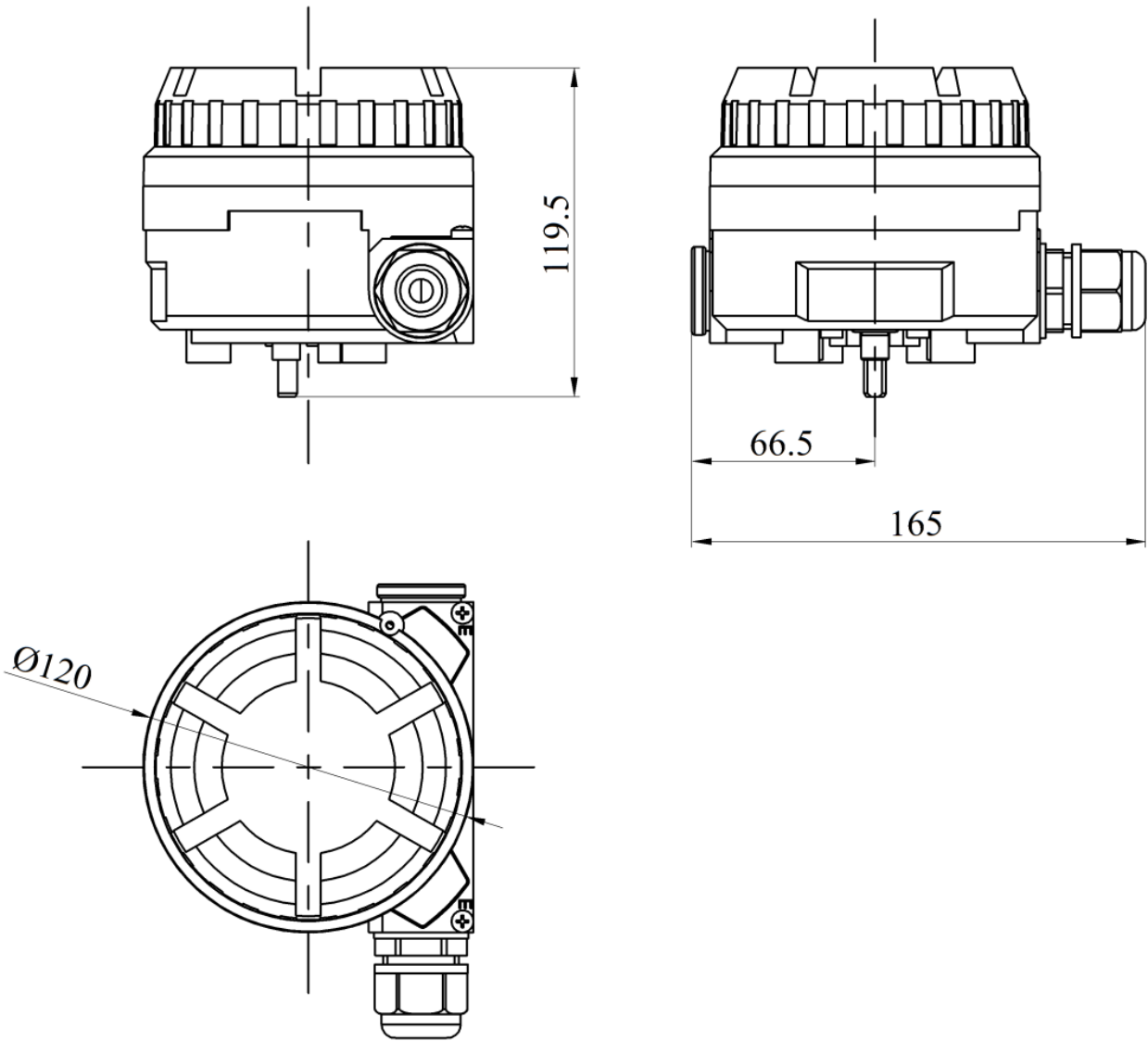

Figure 10. Sensor dimension for remote type

7. Installation

7.1. Linear stroke (normal type or remote type)

Linear actuator mounting components			
No.	Name	Amount	Note
①	U-shaped rod	1	Rotate the feedback lever in the working process
②	Clamping assembly	1	Mount U-shaped rod to actuator
③	M6 hexagon socket screw	2	M6×25
④	M6 spring washer	2	Prevent screw loosening
⑤	feedback lever	1	Mounted on the main stem of the positioner
⑥	M6 hexagon socket bolt	1	M6×20, match with square nut
⑦	Linear stroke mounting bracket	1	Connect positioner and actuator
⑧	M8 hexagon head bolts	2	M8×10
⑨	M8 spring washer	2	Prevent bolts loosening
⑩	M8 flat washer	2	Protect contact surface
⑪	Driving pin for feedback lever B	1	Mounted on the main stem of the valve

7.1.1. Installation of general piping connections

1. Confirm the initial position of the feedback axis of the positioner or the remote sensor

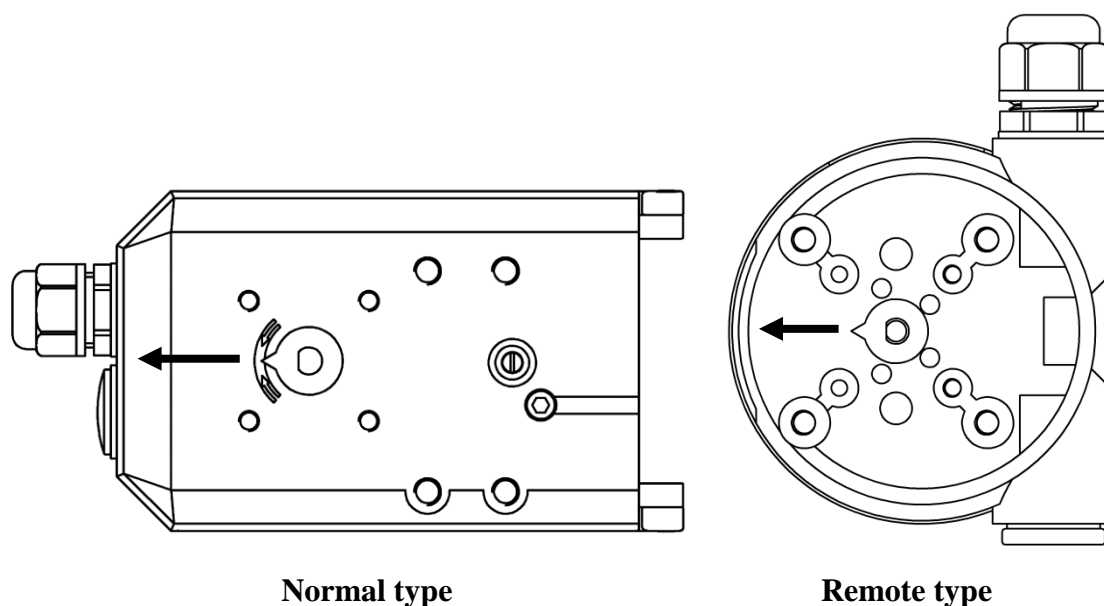

Figure 11. Initial position of the feedback axis

Rotate the feedback axis and point the pointer on the feedback axis in the direction of arrow in Figure 11. The direction of arrow is defined as the initial position. Power on the positioner,

observe the percentage value of the sensor on the initial interface (NOINI), and confirm that the value is between 40-60%. If not, turn the feedback axis 360° and confirm again. After confirmation, power off the positioner.

2. Install the U-shaped rod that matches the feedback lever A or the driving pin that matches the feedback lever B to the actuator.

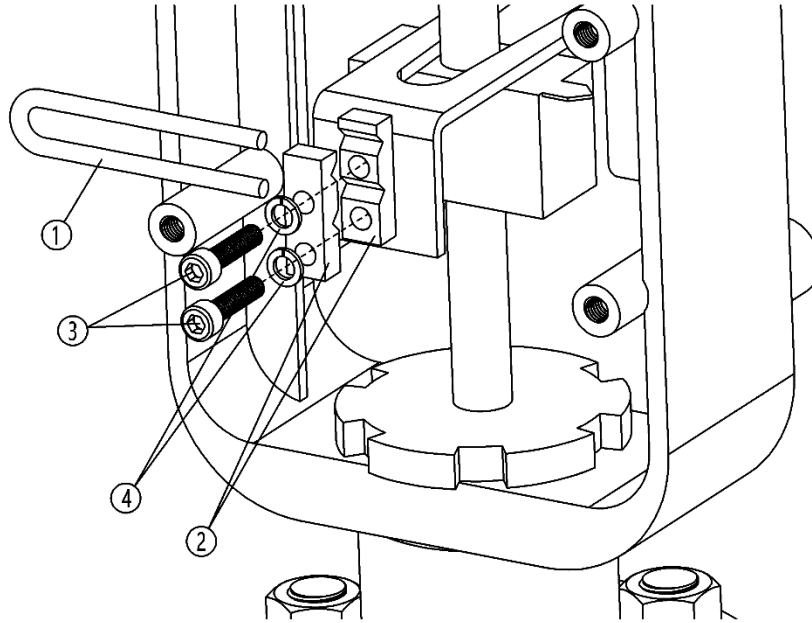

Figure 12. U-shaped rod installation

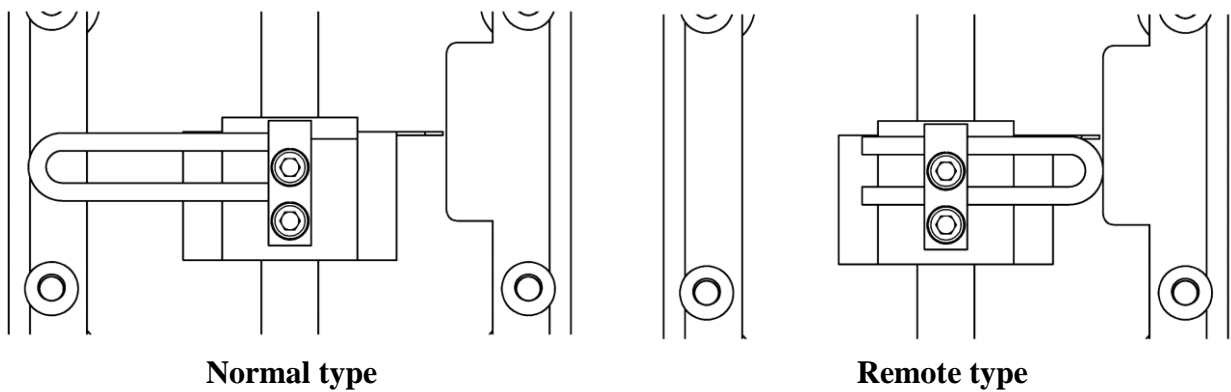

Figure 13. U-shaped rod direction

Fix U-shaped rod① and Clamping assembly② on the actuator center spindle with M6 hexagon socket screw③ and M6 spring washer④, and tighten screws with a hexagon socket wrench.

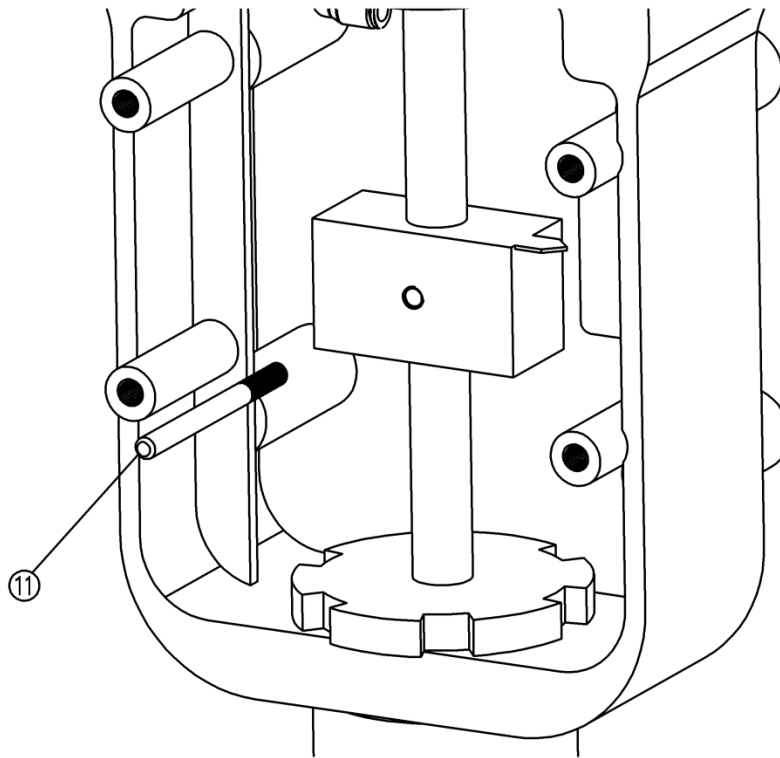

Figure 14. Driving pin installation

Install the driving pin ⑪ on the main stem of the valve. The slot height of the feedback lever B is 6.2 mm. Therefore, if the user does not use the provided driving pin, it should be noted that the diameter of the driving pin used is 6 mm, and the thread size of the driving pin and the main stem of the valve must be the same.

3. Install the driving pin that matches the feedback lever A.

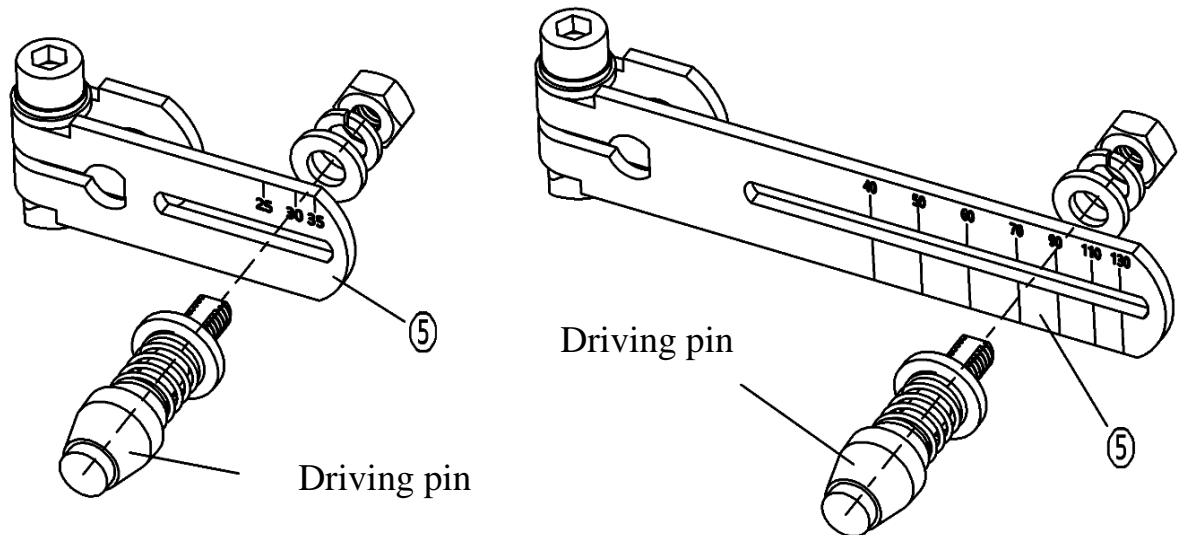

Figure 15. Driving pin that matches the feedback lever A installation

Select the feedback lever corresponding to the figure above according to valve actual stroke. The pin must be mounted at the corresponding stroke scaling value at the feedback lever, if it's not, the lever may be damaged when the valve is activated. For example, mounting driving pin at value 40 position for a valve with 100mm stroke, the feedback lever may be deformed when the valve is activated. If the valve stroke is out of the range of feedback lever A, please consult

the manufacturer.

4. Mount feedback lever and linear mounting bracket to the positioner or the remote sensor.

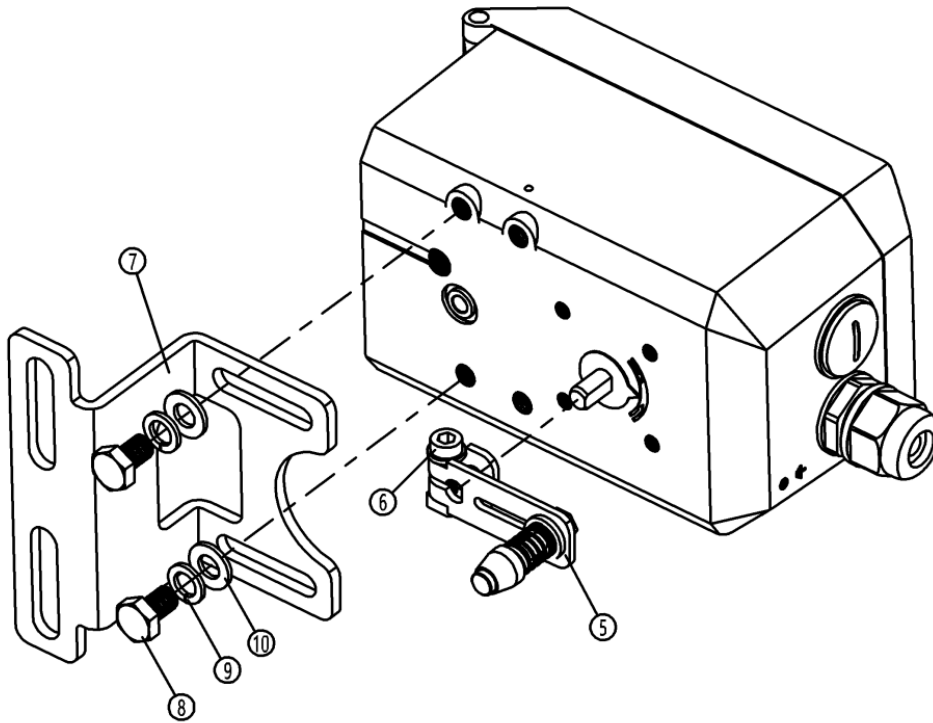

Figure 16. Feedback lever A and mounting bracket installation (normal type)

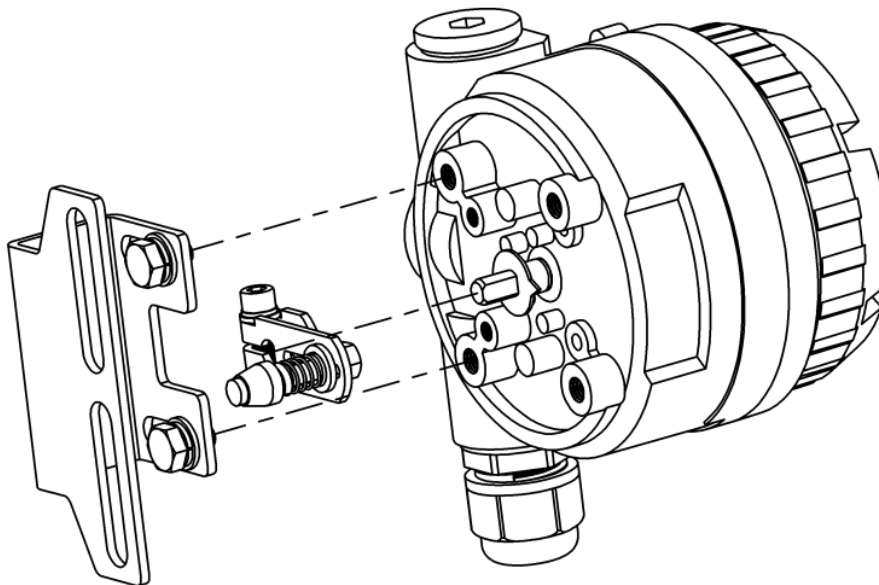

Figure 17. Feedback lever A and mounting bracket installation (remote type)

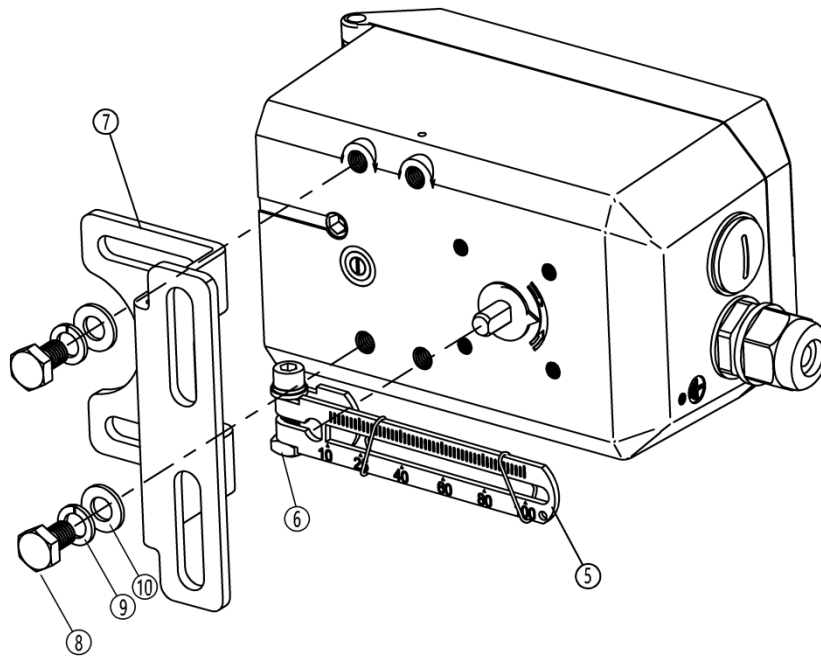

Figure 18. Feedback lever B and mounting bracket installation (normal type)

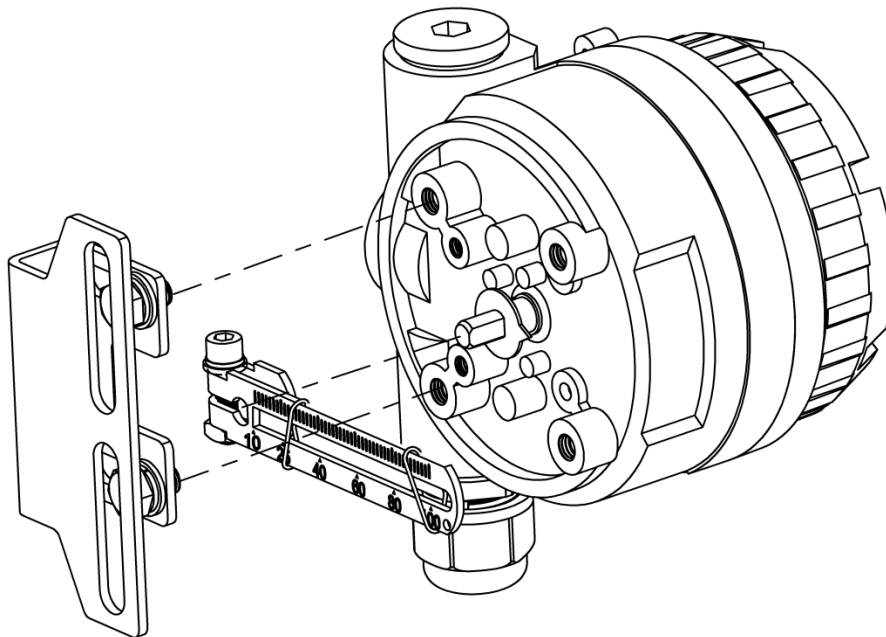

Figure 19. Feedback lever B and mounting bracket installation (remote type)

- Mount the feedback lever A or B (5) to the feedback axis on the rear of the positioner or the remote sensor.
- Check whether the NUMAR lever stroke is within the operational range regarding to the arrow mark.
- Fix the hexagon socket bolt (6) with hexagon socket wrench.
- Pre-fasten the mounting bracket (7) to the positioner or the remote sensor with hexagon head bolts (8), spring washer (9) and flat washer (10).

5. Fix linear mounting bracket to the actuator.

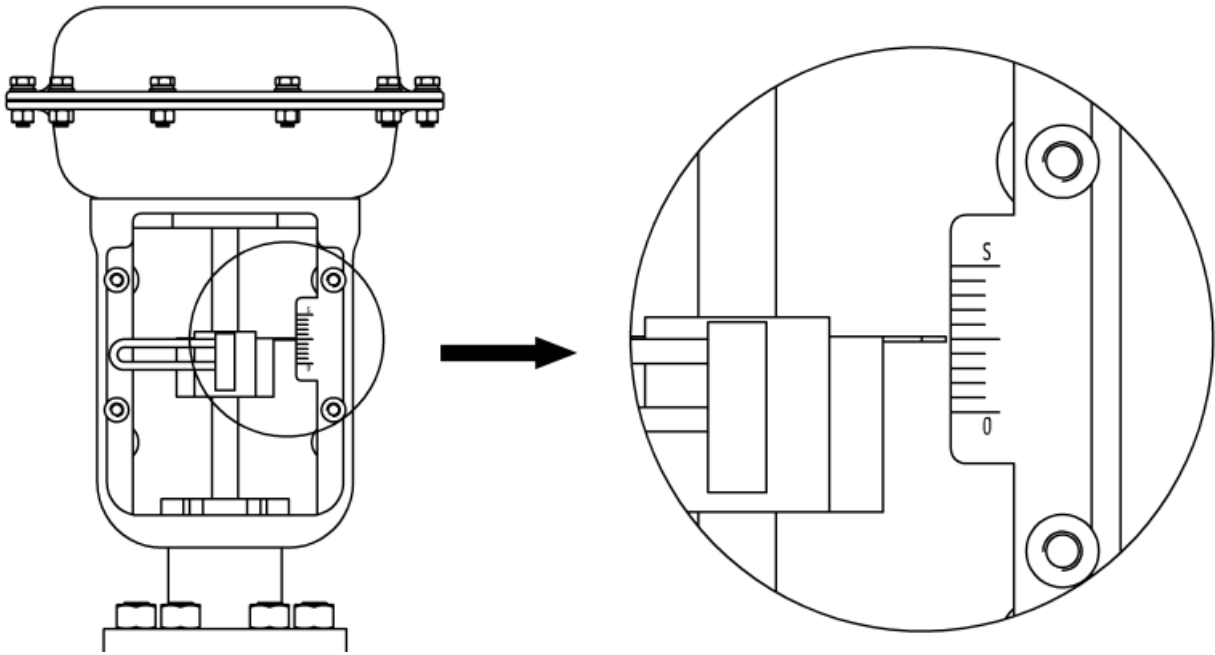

Figure 20. Valve mid-stroke point

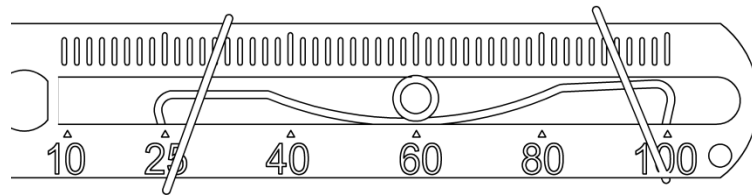

Figure 21. Feedback lever B and driving pin connection

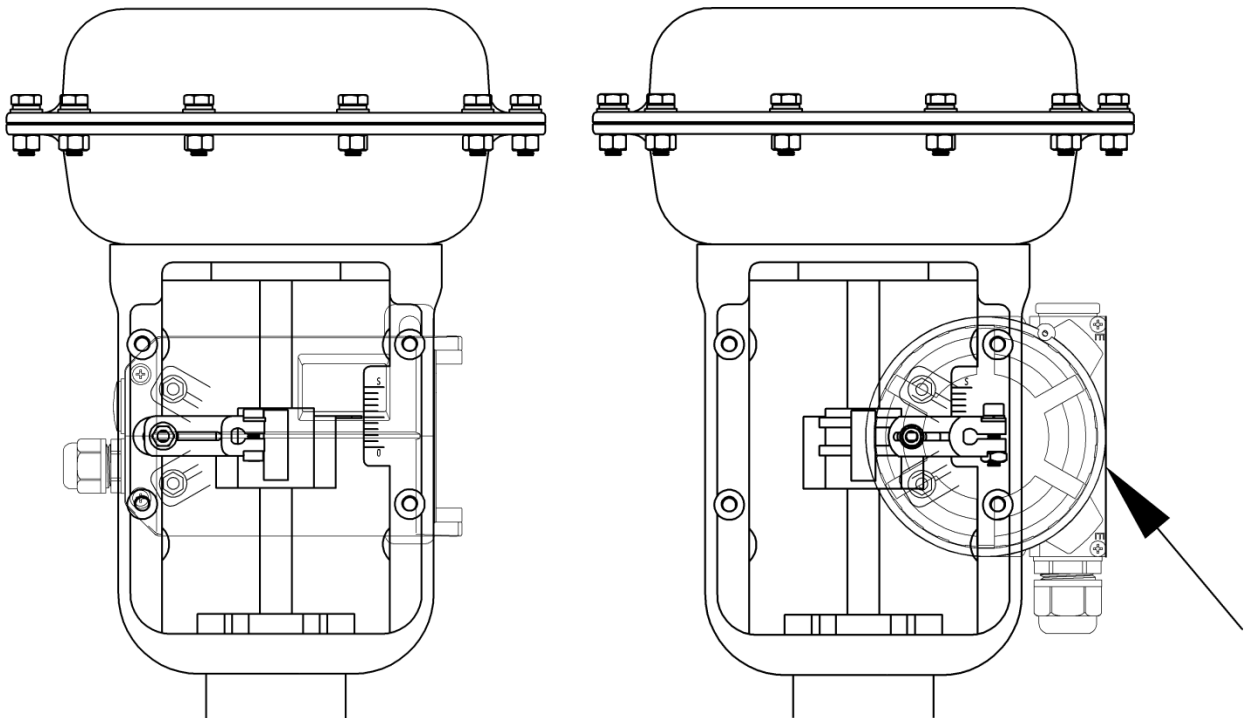

Figure 22. Installation with actuator (Feedback lever A)

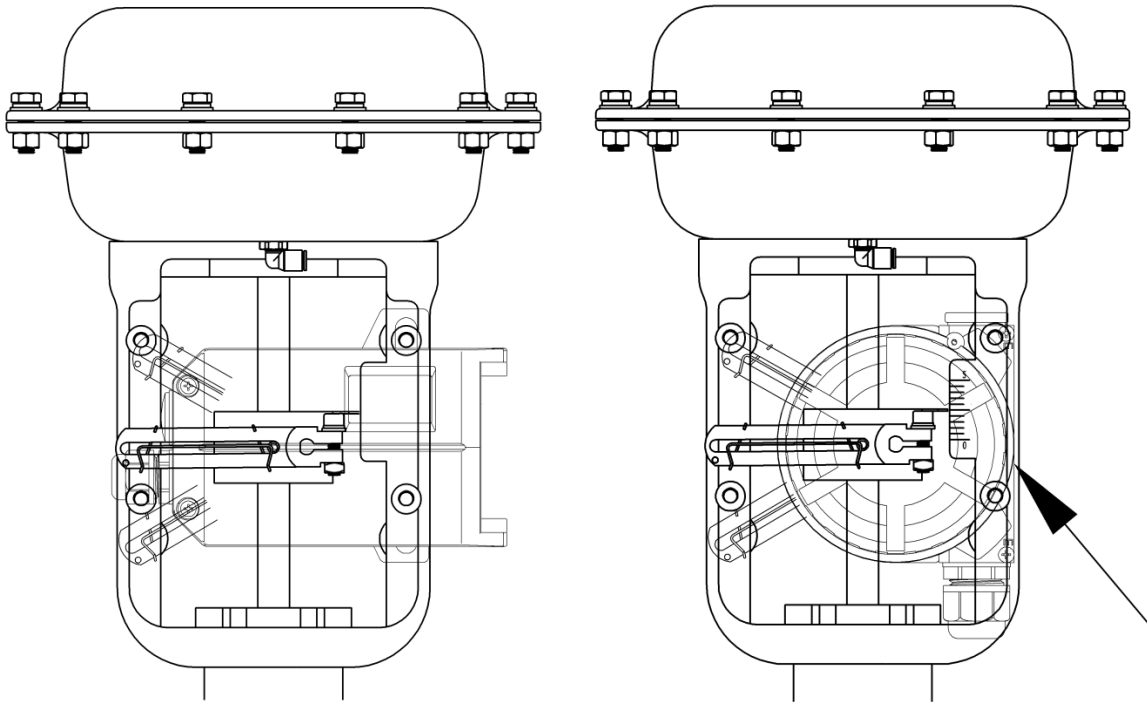

Figure 23. Installation with actuator (Feedback lever B)

- Input air to the valve cylinder, adjust the valve position to the mid-stroke point according to the stroke ruler on the valve, as shown in Figure 20.
- For feedback lever A, hold the linear stroke mounting bracket⑦ against the actuator. Plug the head of feedback lever⑤ into the U-shaped rod①. For feedback lever B, insert the driving pin⑩ into the fixed spring in the slot of the feedback lever B, as shown in Figure 21. Make the valve main stem and feedback lever are at right angle. If it cannot be at right angle, install according to the actual situation.
- The whole rotary angle is recommended to be between 40°~90°. User can adjust the distance (Angle rotation radius) between the driving pin and the rotation shaft of the positioner or the remote sensor to change the angle.
- For the positioner of normal linear type, make the upper plane of the positioner housing at a right angle to the main stem of the valve. For the positioner of remote linear type, make the plane indicated by the arrow (on the right side of Figure 22 and Figure 23) on the sensor housing and the main stem of the valve are parallel to each other. Otherwise it will affect the control accuracy. Finally, tighten the bracket with bolts.

6. Overall schematic diagram.

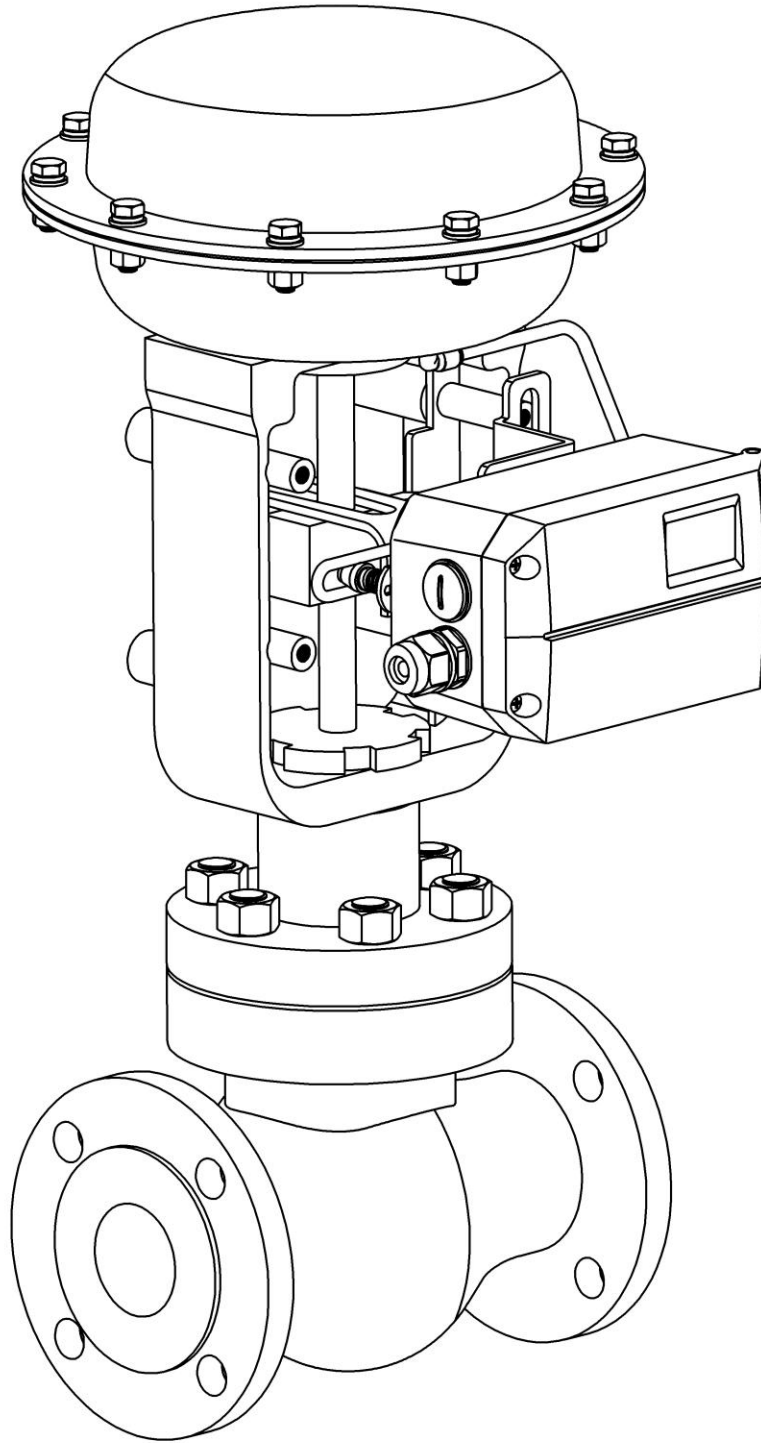

Figure 24. Linear stroke for normal type (Feedback lever A)

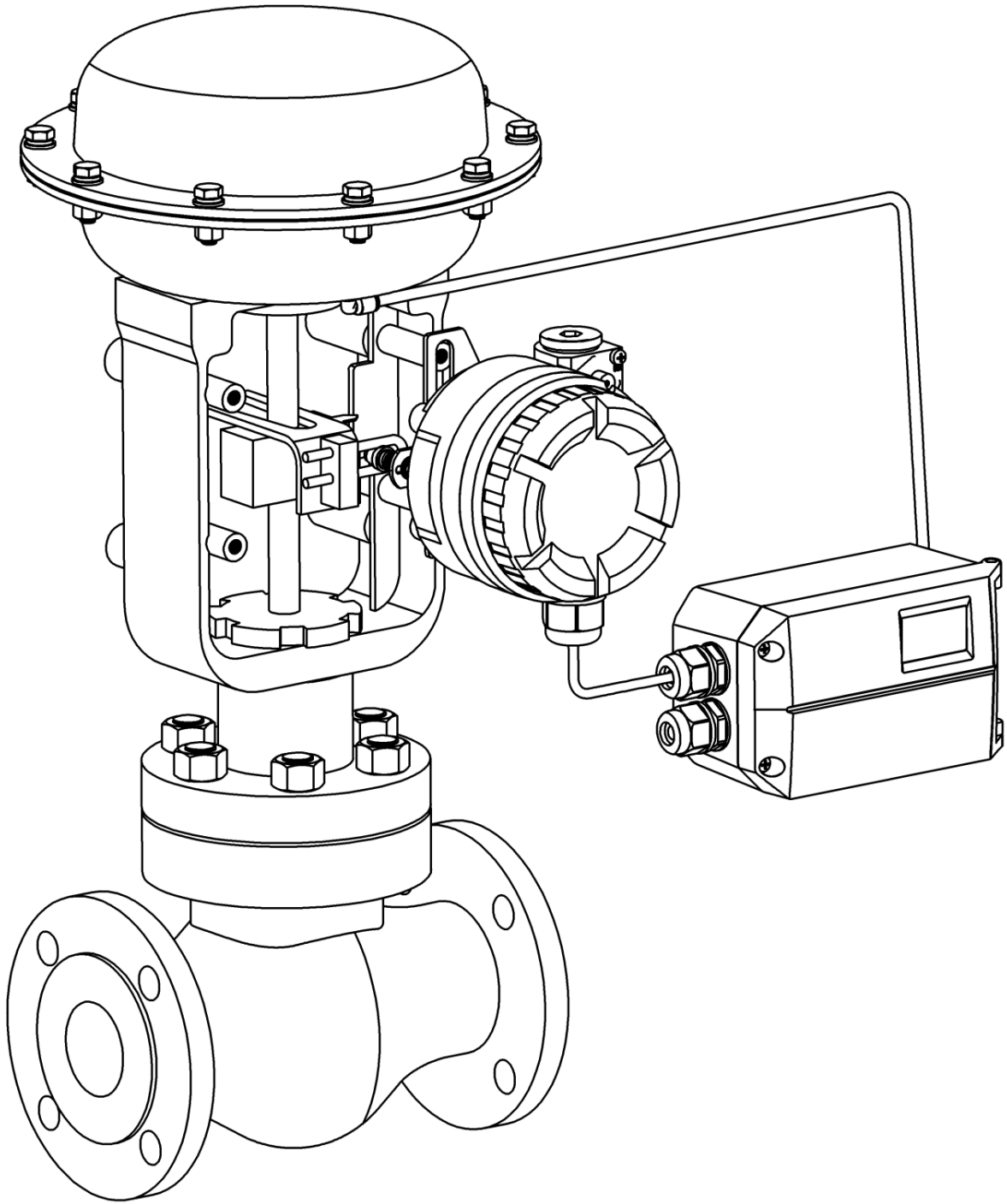

Figure 25. Linear stroke for remote type (Feedback lever A)

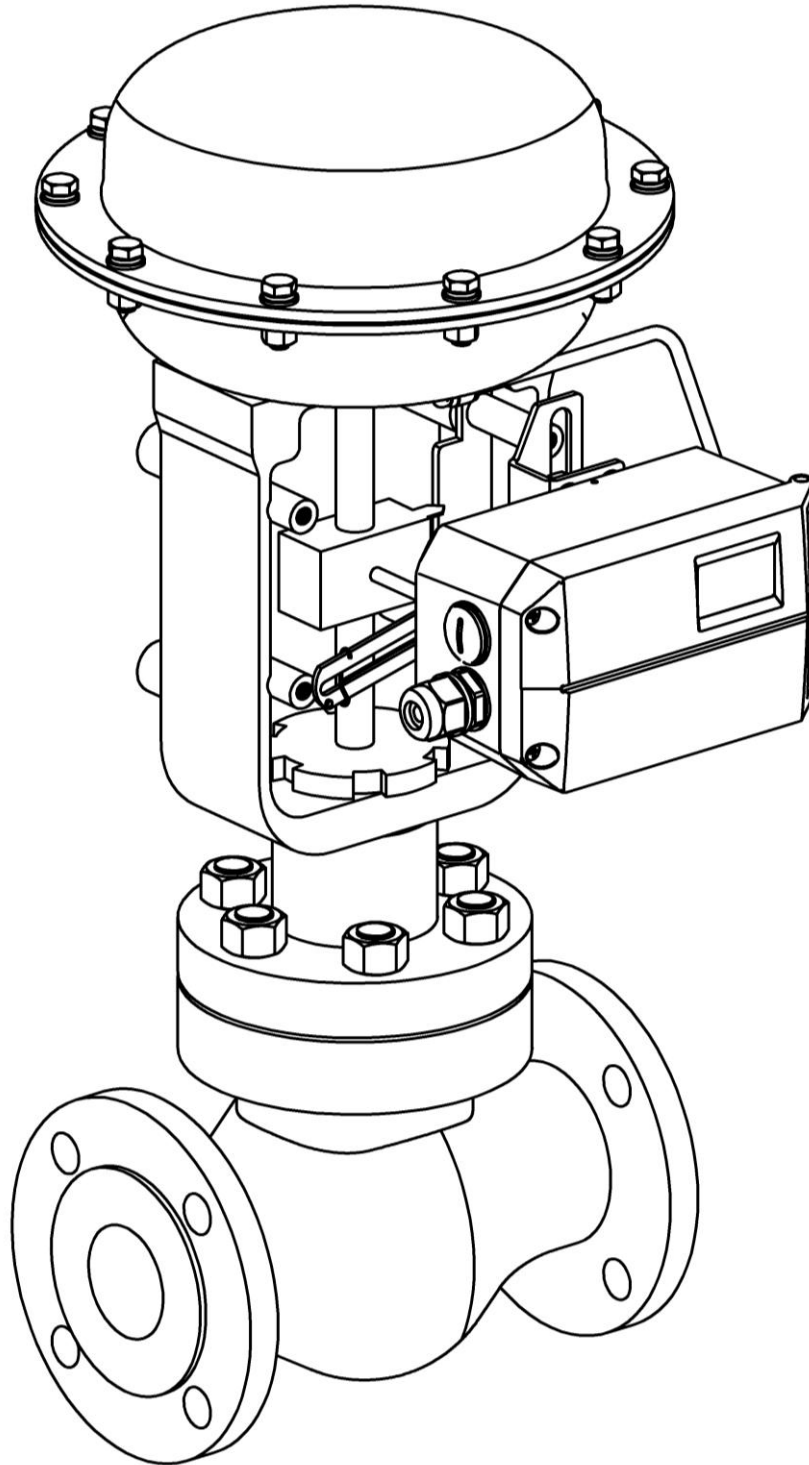

Figure 26. Linear stroke for normal type (Feedback lever B)

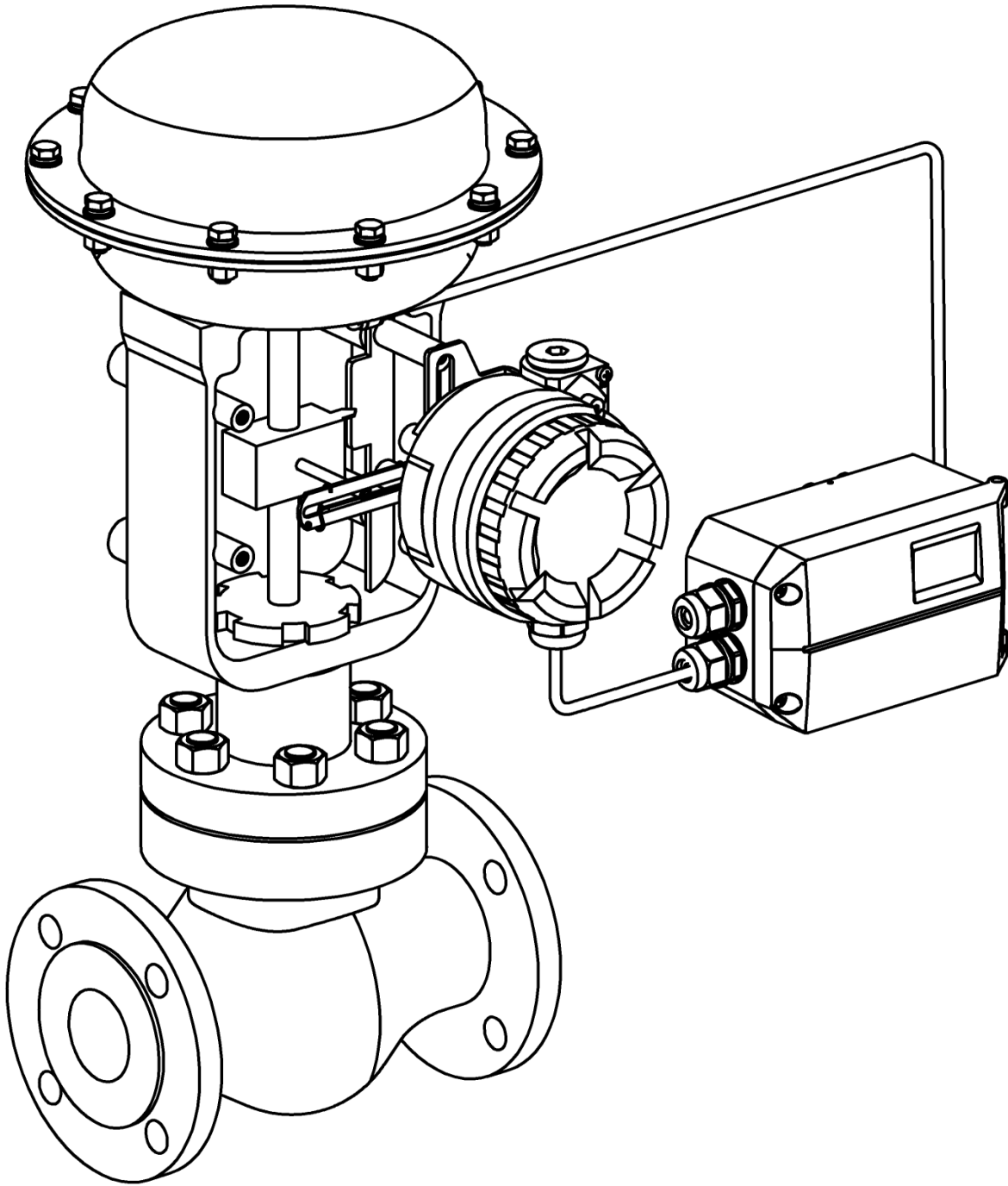

Figure 27. Linear stroke for remote type (Feedback lever B)

7.1.2. Installation of no piping connections

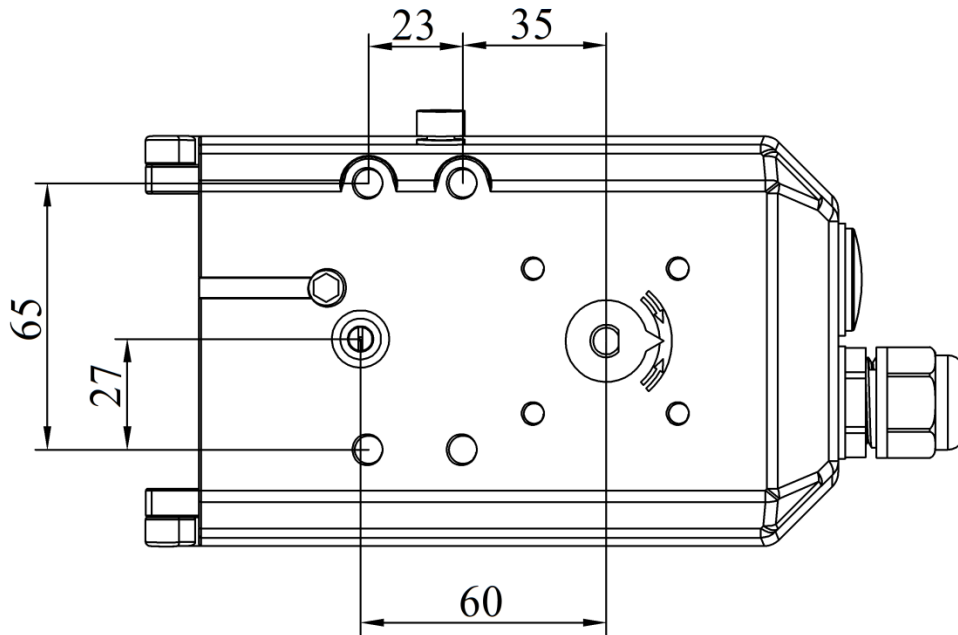

Figure 28. Relative position of no tubing connection holes and mounting holes

Refer to the installation of general piping connection, and pay attention to the following differences:

- Use a flathead screwdriver to remove the plug for no tubing connection on the back of the housing and block the air outlets OUT1 and OUT2 with a 1/4" plug. As shown in Figure 29.

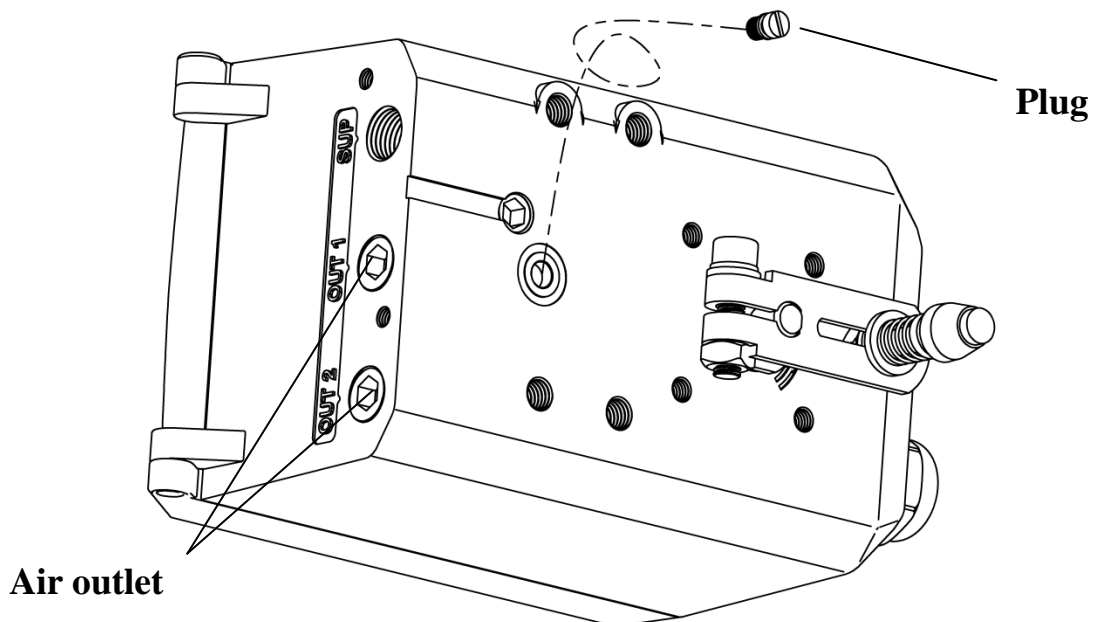

Figure 29. Schematic diagram of plug and air outlet

- No mounting bracket is required. Two M8 long screws are used to fix the positioner to the actuator without piping connections. Confirm that the sealing ring for no piping connection port is in good condition, and confirm that the feedback rod is correctly connected to the actuator

shaft.

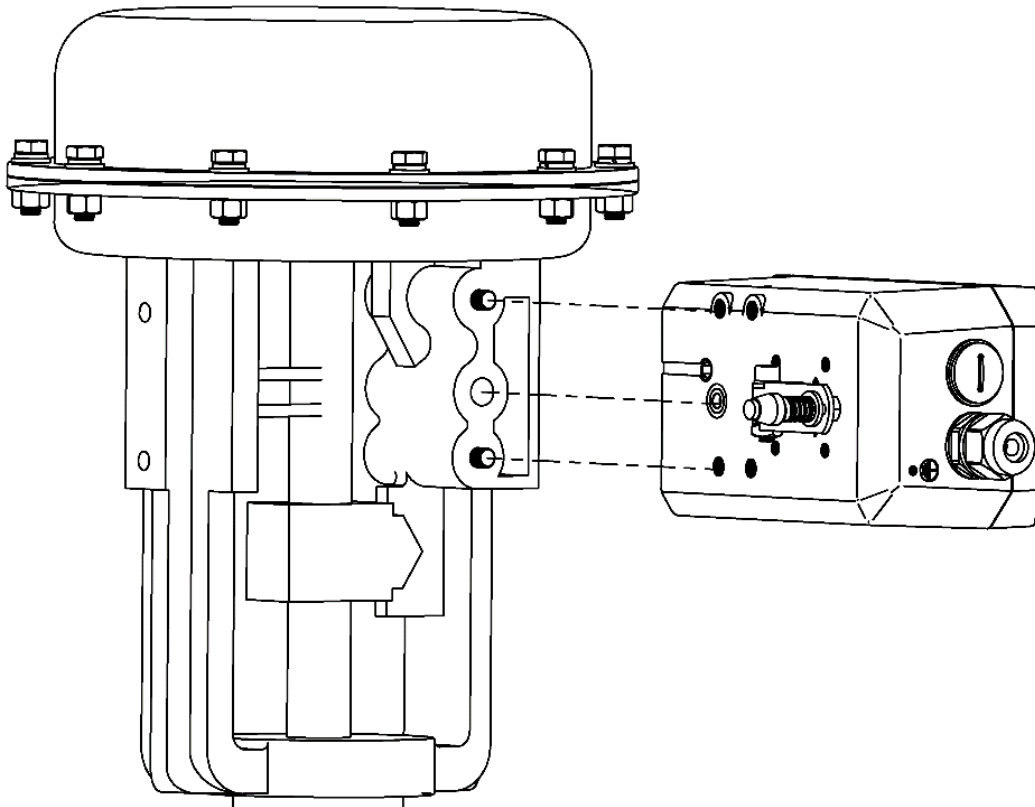

Figure 30. Mount to the actuator without piping connections

7.2. Rotary stroke (normal type or remote type)

Rotary actuator mounting components			
No.	Name	Amount	Note
①	Adapter	1	Mounted on the positioner main stem.
②	Hexagon socket set screw	2	M4×8 , fix adapter to the positioner main stem.
③	Rotary stroke mounting bracket	1	Compatible for actuators in different specifications.
④	M6 flat washer	4	Protect contact surface
⑤	M6 spring washer	4	Prevent screw loosening
⑥	M6 hexagon socket screw	4	M6×10
⑦	M5 hexagon socket screw	4	M5×8
⑧	M5 spring washer	4	Prevent screw loosening
⑨	M5 flat washer	4	Protect contact surface

Note before installation:

Please make the following preparations. In the installation steps, the first situation shown in Figure

31 is taken as an example. Figure 31 shows the slot direction and rotation direction of the actuator rotation axis at the initial position. ↓ indicates the position of the actuator pneumatic interface.

- Adjust the actuator rotation axis to the initial position. For single-acting actuators, exhaust the air from the actuator cylinder fully. For double-acting actuators, exhaust the air from one cylinder and fill the air into the other cylinder fully. Pay attention to the slot direction of the rotation axis at the initial position.
- Confirm the direction of rotation of the actuator axis. For single-acting actuators, fill air into the actuator cylinder at the initial position. For double-acting actuators, at the initial position, fill air into the cylinder which the air inside is fully exhausted, and exhaust air from the other cylinder which is filled with air. In this way, the direction of rotation of the rotating axis is judged.
- Rotate the pointer of the positioner feedback axis to the corresponding position shown in the following picture, and be sure to rotate the feedback axis within the range of the rotation mark.
- Place the adapter in the direction corresponding to the following picture.

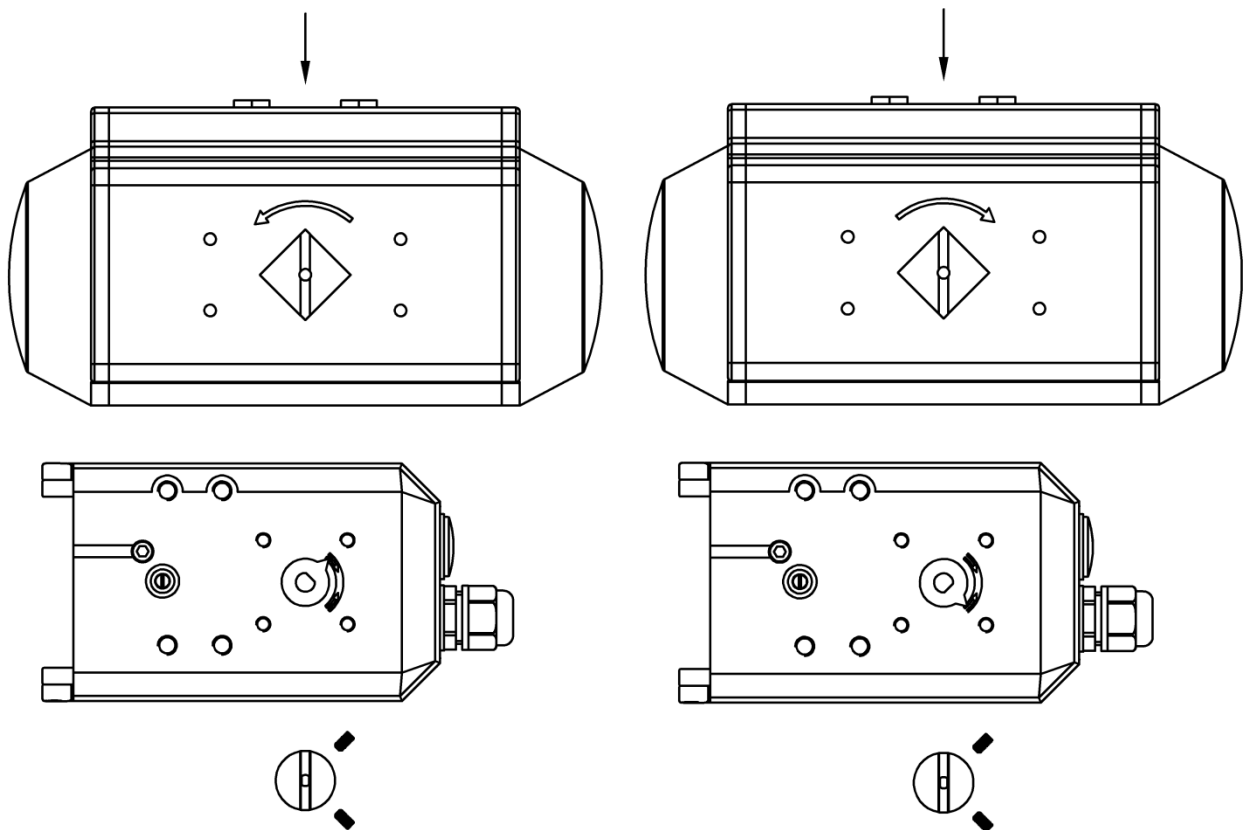

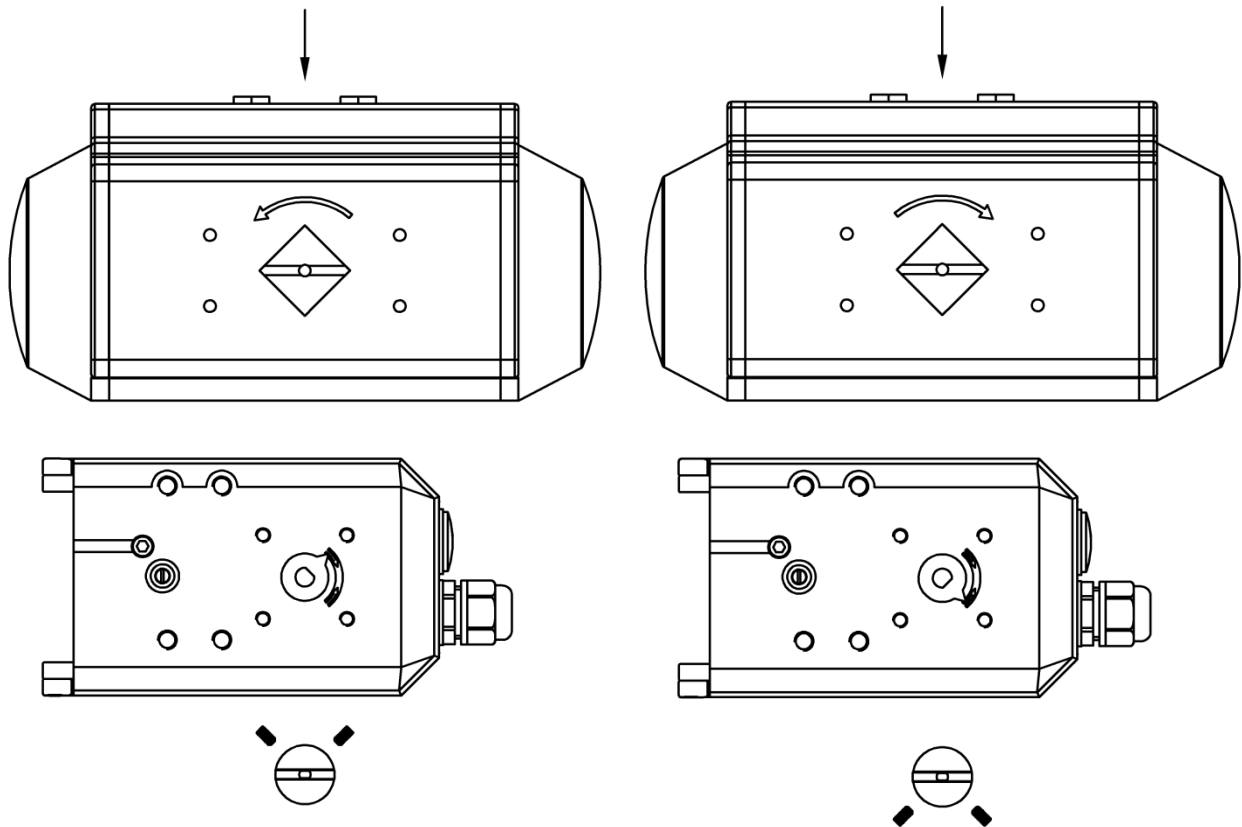

Figure 31. Four cases of installation matching

- Pay attention to the difference between the remote type and the normal type. For the installation of the remote type, please refer to the installation of the normal type.

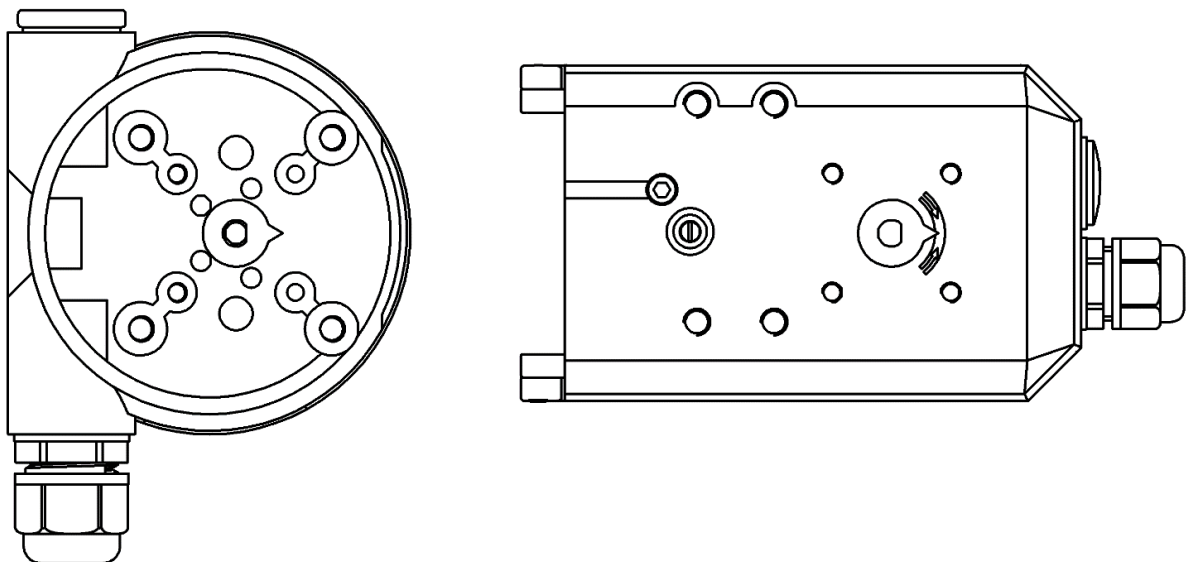

Figure 32. Comparison of the feedback axis pointers (remote type and normal type)

1. Confirm the initial position of the feedback axis of the positioner or the remote sensor (The operation is the same as the linear stroke installation in chapter 7.1).
2. Mount the adapter to the feedback axis of the positioner or the remote sensor.

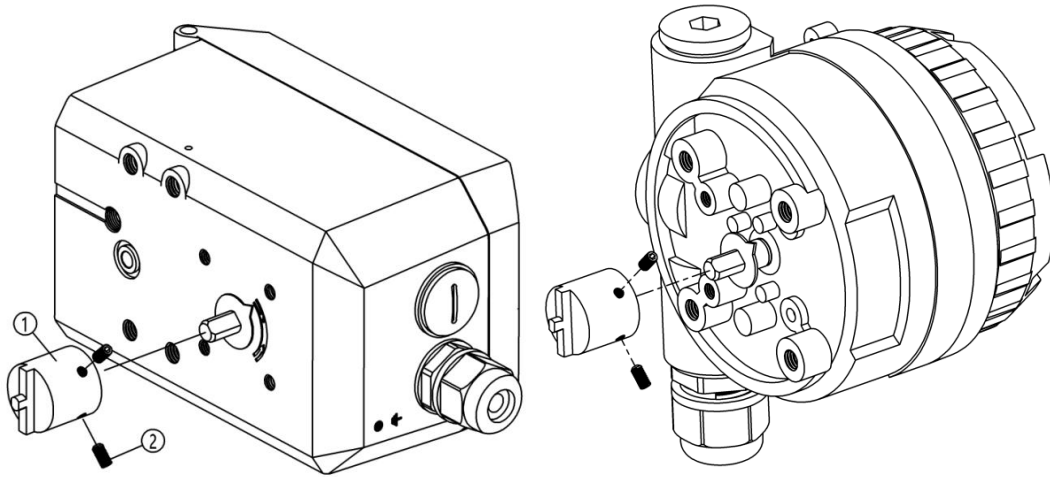

Figure 33. Adapter installation

Attach the adapter to the feedback axis in the direction in which it was prepared, and fix it with set screws②. Make sure one of the set screws is locked on the flat side of the feedback axis.

3. Mount rotary stroke mounting bracket to the bottom of the positioner.

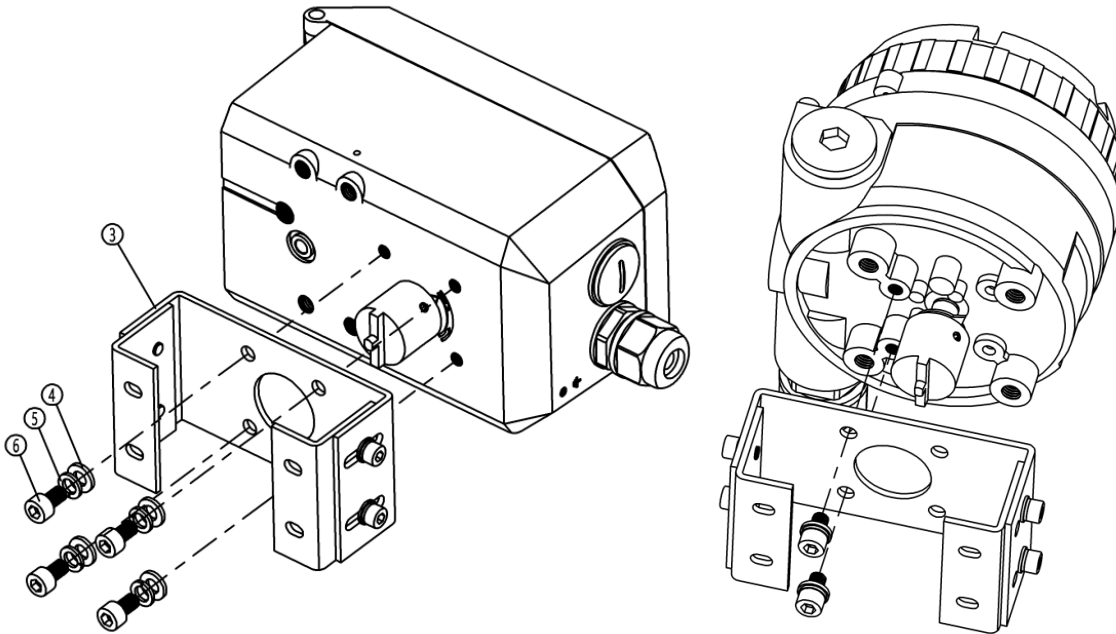

Figure 34. Rotary stroke mounting bracket installation

4. Mount the rotary stroke mounting bracket to the actuator.

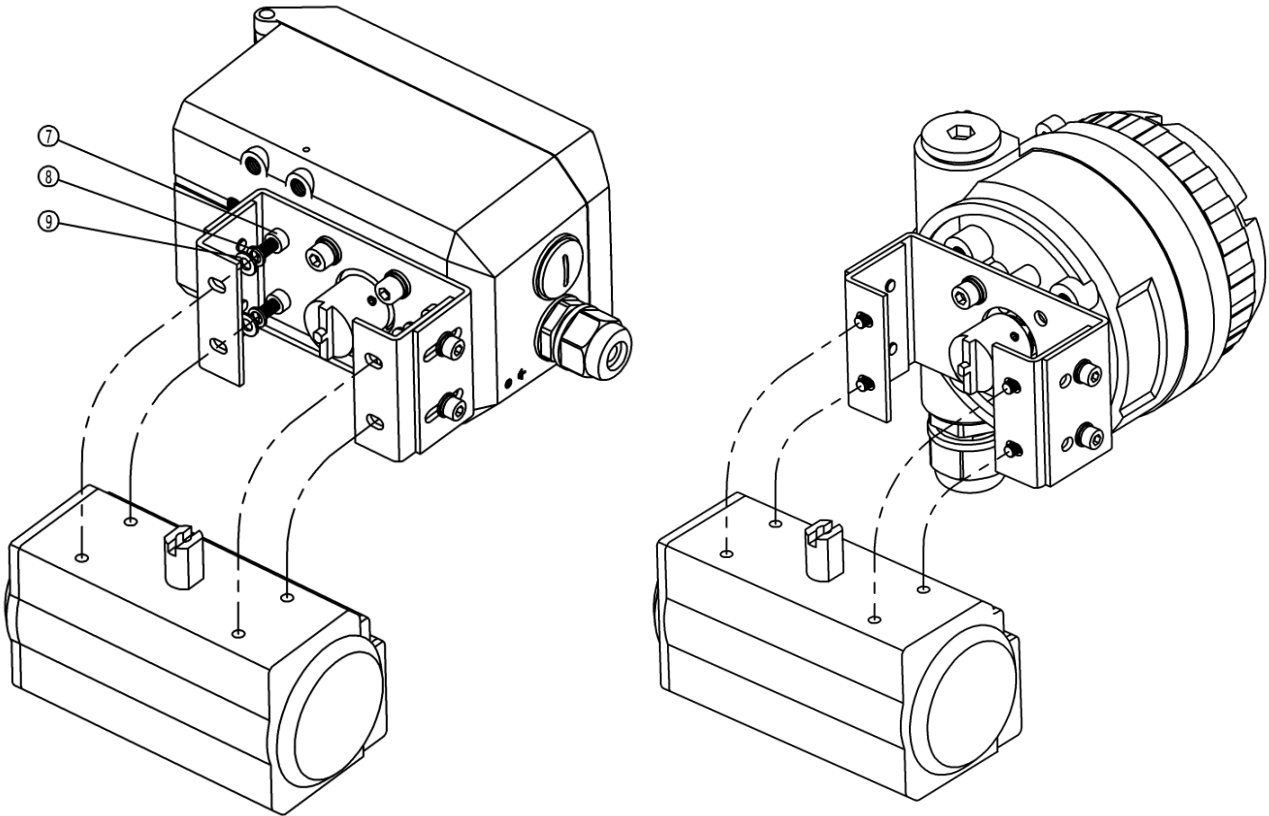

Figure 35. Installation with actuator

5. Overall schematic diagram.

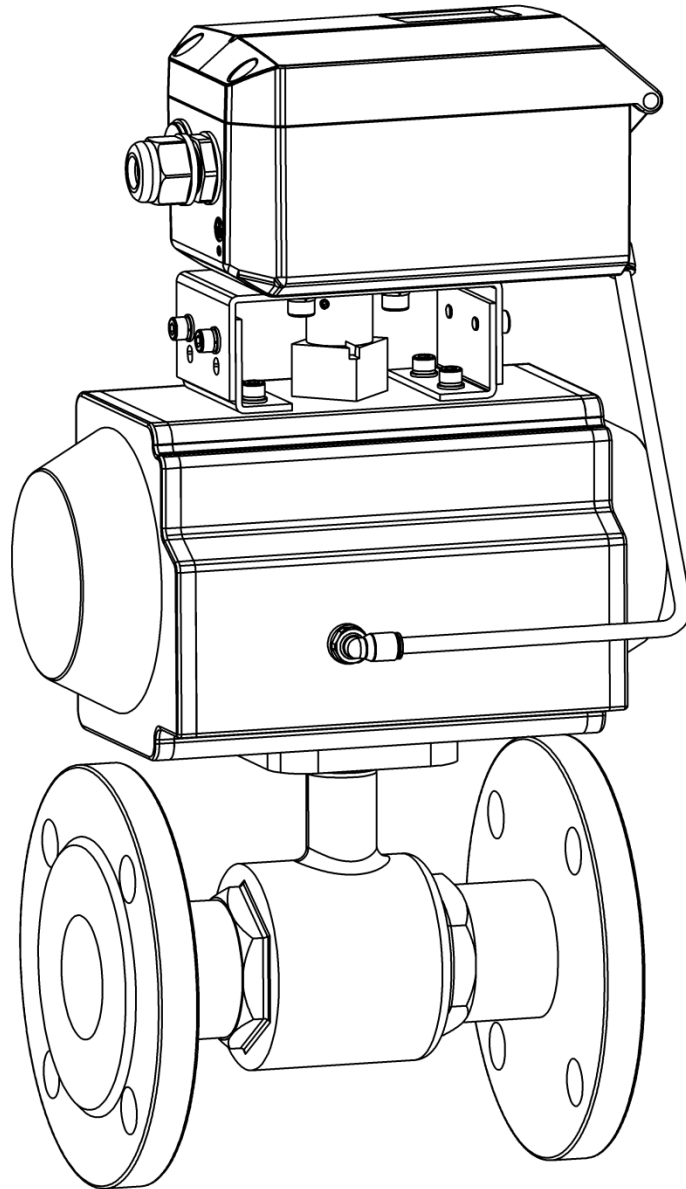

Figure 36. Rotary stroke for normal type

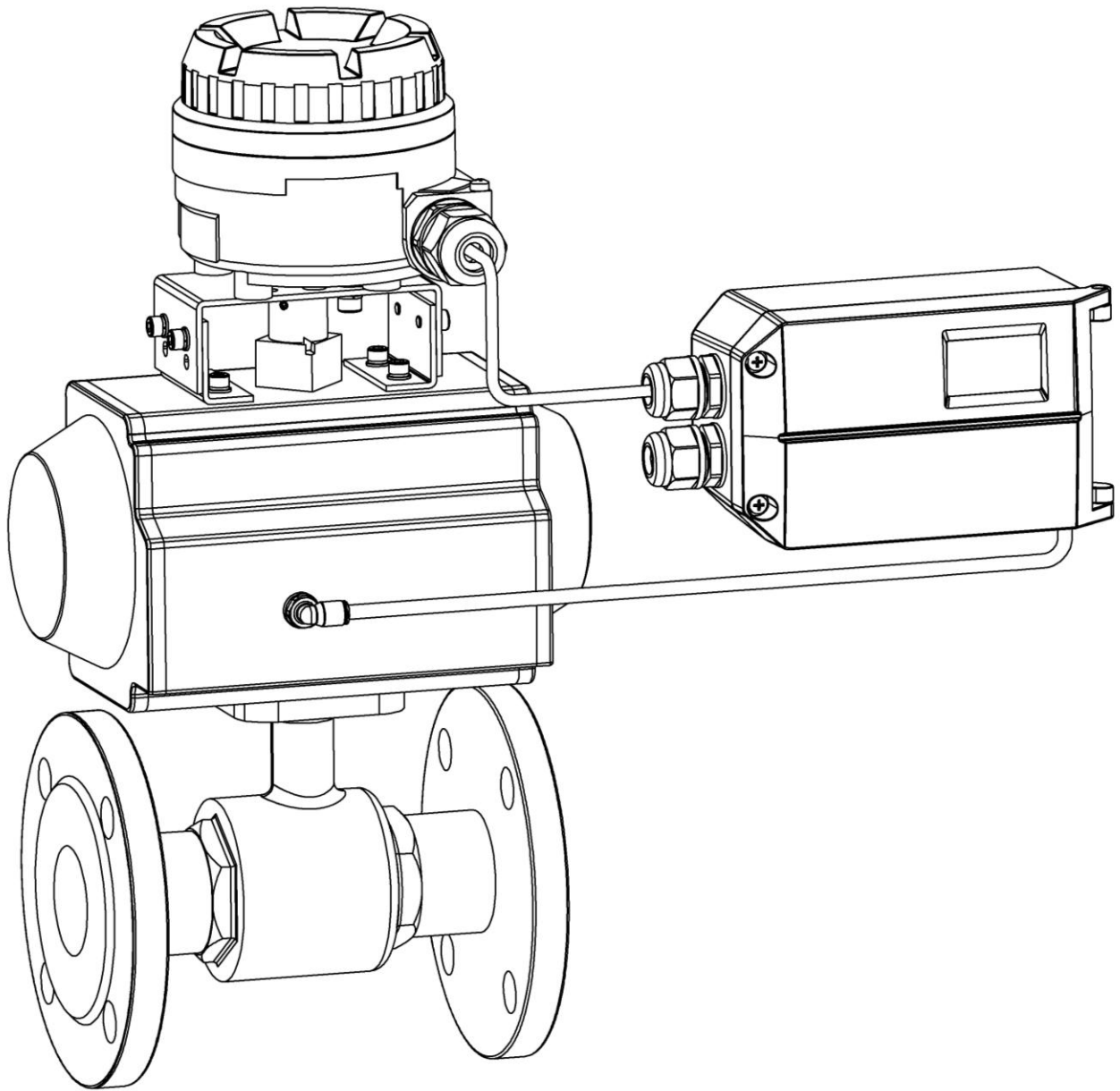

Figure 37. Rotary stroke for remote type

7.3. Separate type

Separate type mounting components			
No.	Name	Amount	Note
①	Sensor	1	Feedback the valve opening position
②	Mounting plate	1	Connect the positioner and the actuator
③	O-ring	2	Φ20×2
④	Fastener	2	Fix the mounting plate, G1/4 Thread
⑤	M8 hexagon head bolts	4	M8×16
⑥	Sensor connector	1	Connect the sensor to the positioner

1. Assembly of the sensor and the actuator.

- Make sure that the stroke range and the screw thread size of the actuator which needs to combine meet the requirements.
- Separately measure the C1 value when the valve is fully closed and C2 value when the valve is fully open by **the depth ruler**. The values are the distance between the stem top and the datum clamp face of the actuator. As shown in Figure 38.

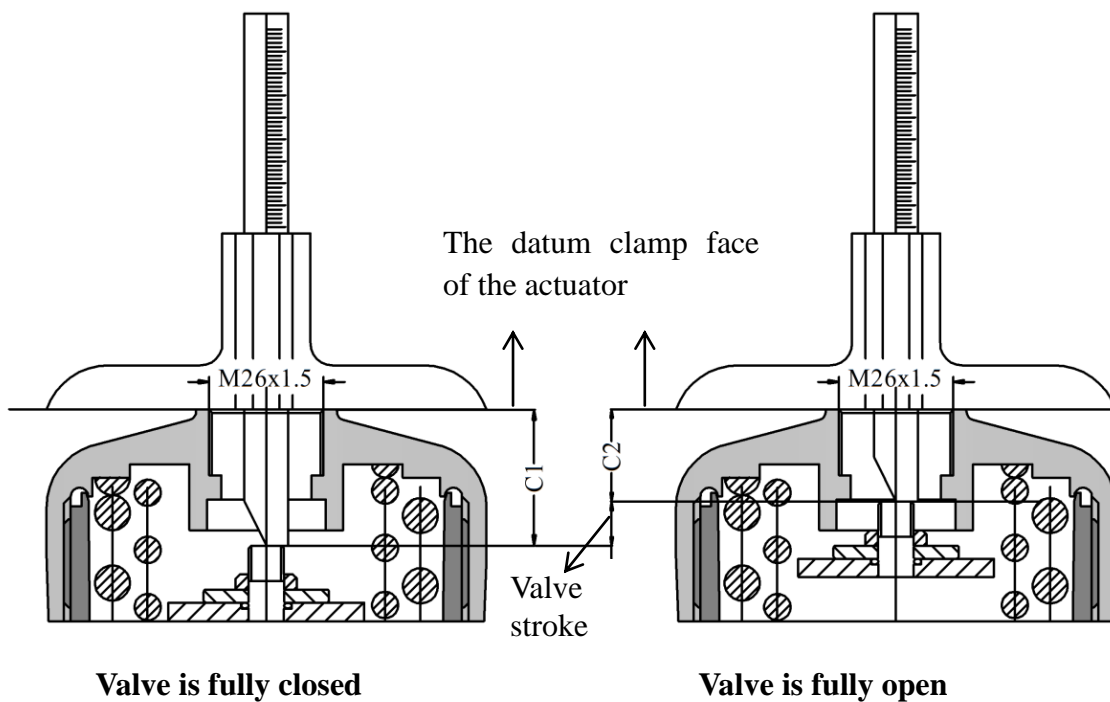

Figure 38. C1 value and C2 value measurement

- Adjust the adjusting nut of the displacement sensor. Then measure the D value (as shown in Figure 39) by **the depth ruler** in the state of the displacement sensor being completely loosened. Calculate the compression value $L1 = D - C1$, $L2 = D - C2$. It is recommended that the compression value L1 and L2 are both in the reference range which is showed in Table below. If L1 value or L2 value is unable to meet the reference range, adjust the D value according to the actual situation.

NOTE: The adjusted D value must ensure that $L1 > 0$, $L2 <$ the maximum compression

value of the displacement sensor. Otherwise, the positioner cannot match the actuator.

Maximum valve stroke	D range	L1, L2 reference range
5~25 mm	45~51 mm	3~28 mm
25~50 mm	65~71 mm	3.5~53.5 mm

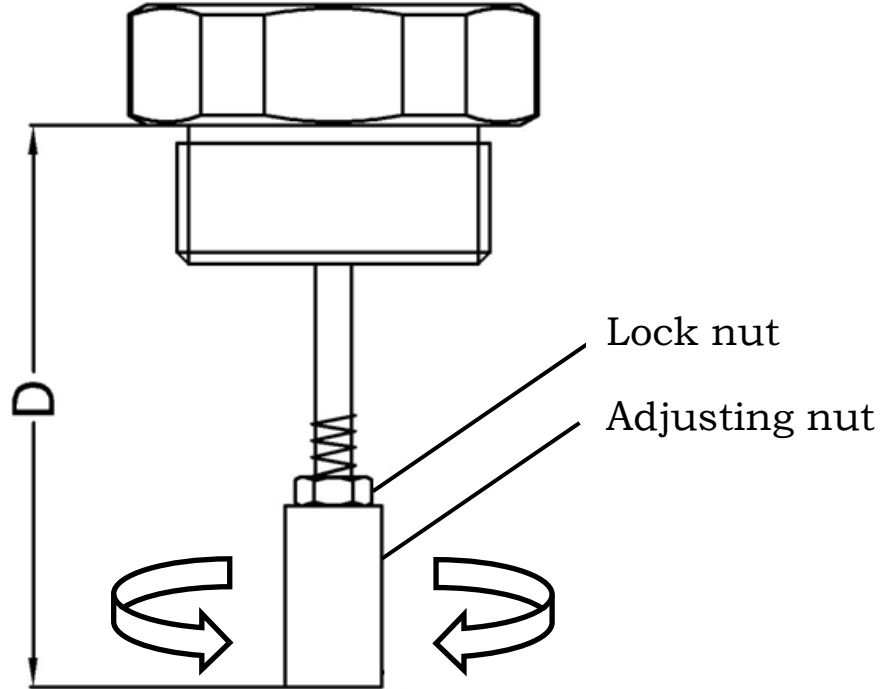

Figure 39. D value adjustment

- Raise the internal valve stem of the actuator to the highest position. Make the actuator connection of the sensor entering into the thread connection of the actuator by **NO.32 wrench**.

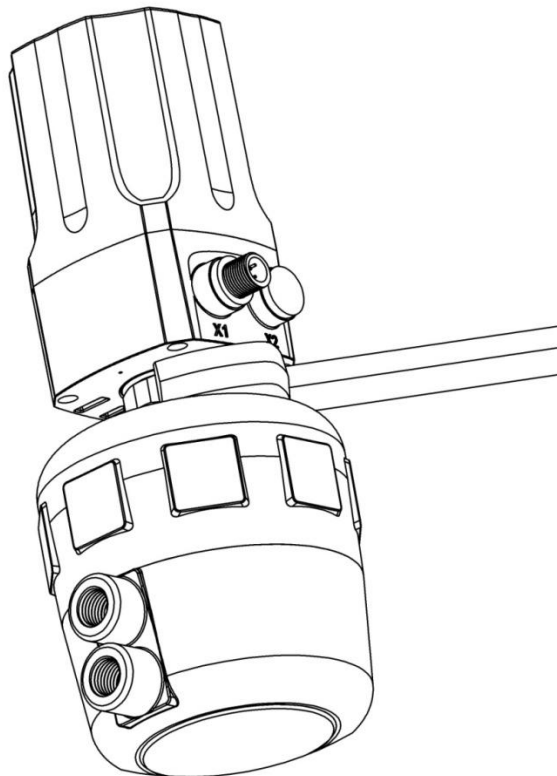

Figure 40. Sensor installation

2. Fix the mounting plate.

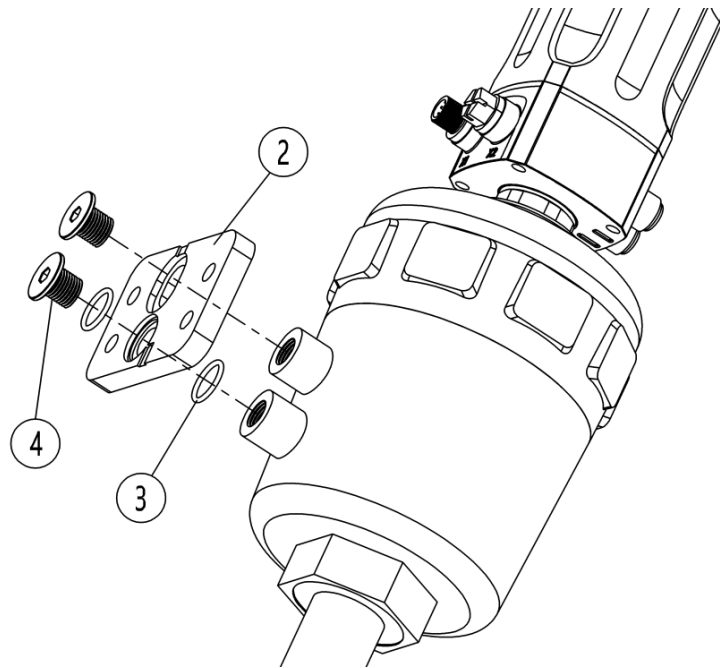

Figure 41. Fix the mounting plate

Put the O-ring③ into the corresponding sealing groove of the mounting plate②, fix the mounting plate② to the corresponding position of the actuator with the fastener④, and tighten it with an Allen wrench. (The contact surface between the O-ring and the actuator should be smooth and flat and it can completely cover the O-ring. The thread specification of the fastener ④ is G1/4, and the corresponding thread specification on the actuator is also G1/4 to install.)

3. Fix the positioner on the mounting plate.

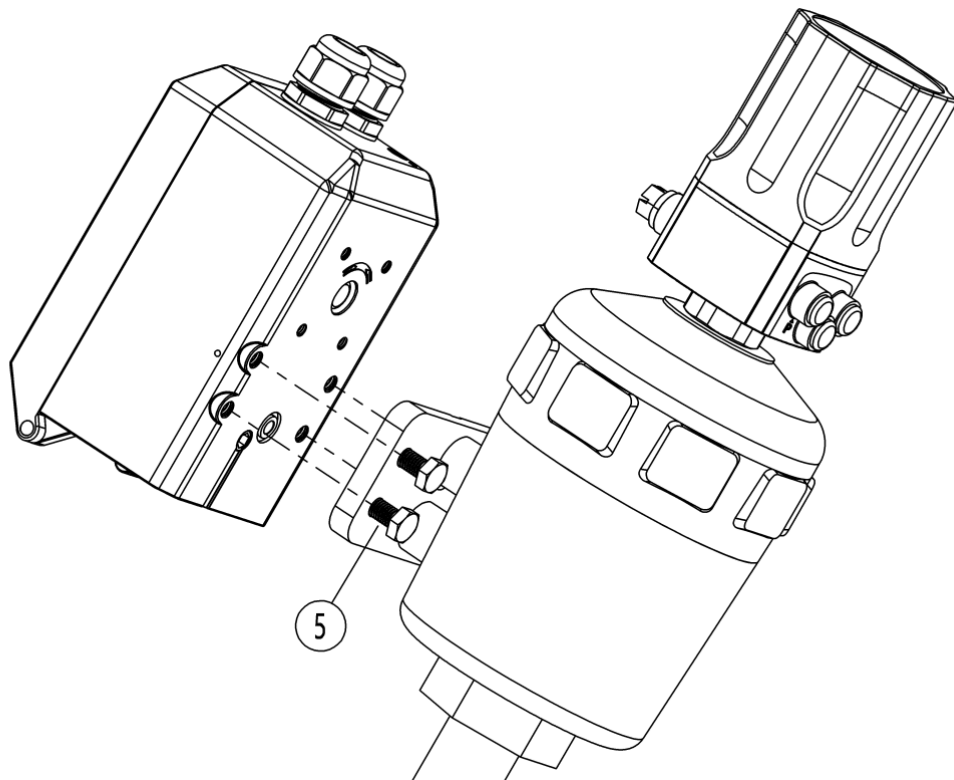

Figure 42. Fix the positioner

Fix the positioner on the mounting plate with hexagon head bolts⑤ and tighten with a wrench.

4. Connect the sensor.

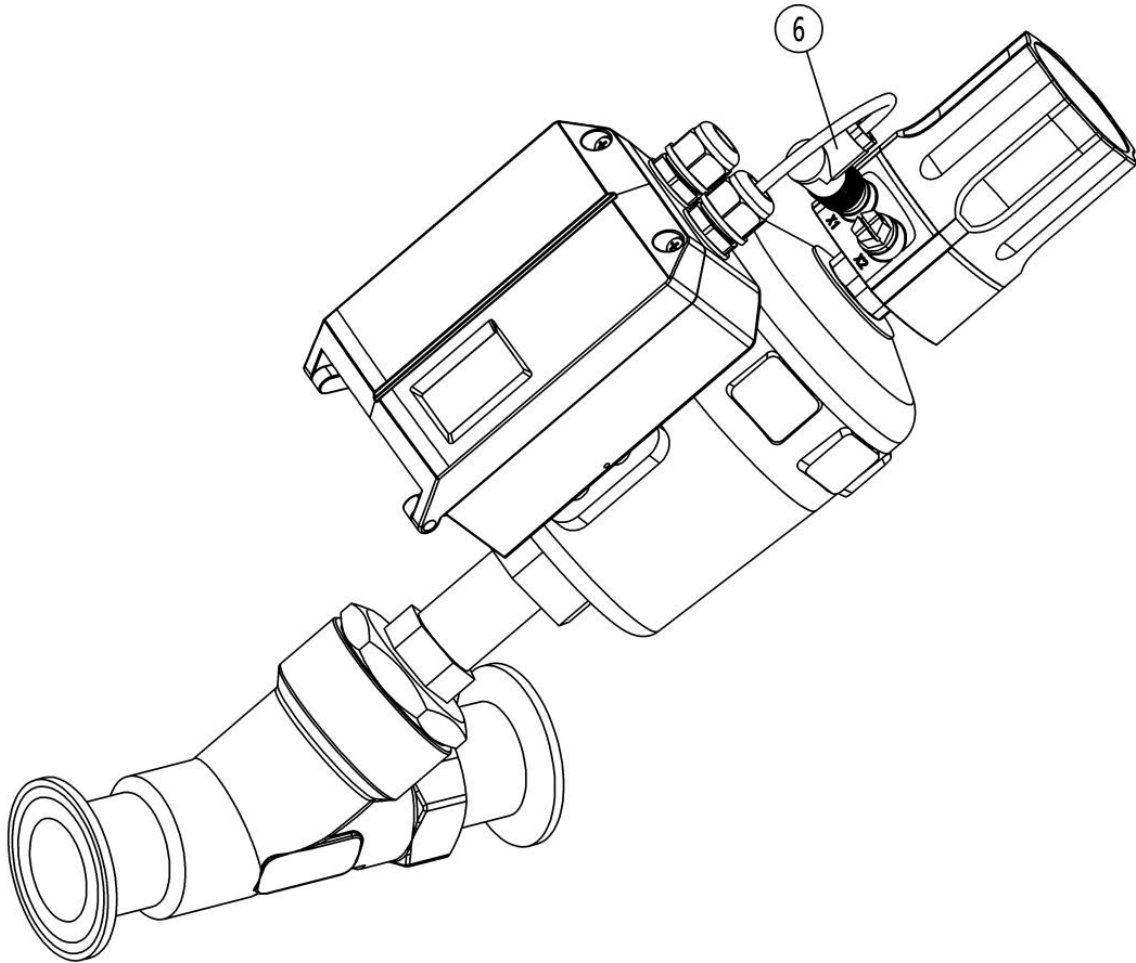

Figure 43. Connect the sensor

Insert the sensor connector⑥ into the corresponding position of the sensor and tighten. (Note: When installing, pay attention to insert the sensor connector into the corresponding limit position in the following figure and tighten it to prevent the sensor connector from being damaged)

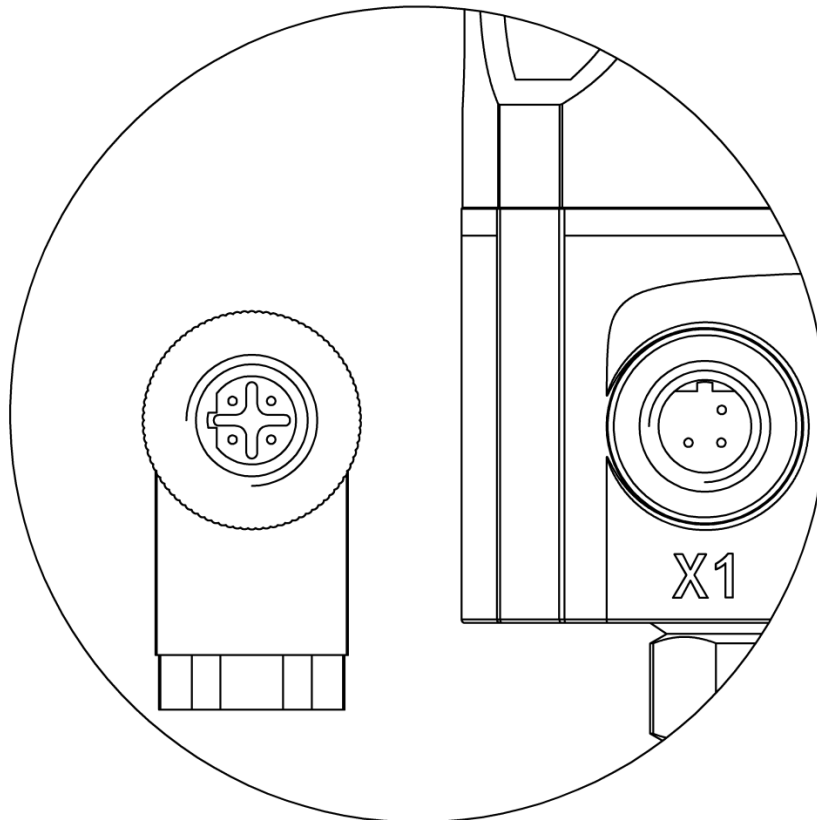

Figure 44. Sensor connector

8. Operation







8.1. Interface description

User's operating interface includes one LCD screen and 4 buttons.

LCD display description

Position	Description
Top line	<ul style="list-style-type: none"> ● Display the percentage value of angle sensor in the initial interface (NOINI) or when running the initialization function. ● Display valve position percentage value in operating mode. ● Display parameter values in menu mode.
Bottom line	<ul style="list-style-type: none"> ● Display indication signs in uninitialized state. ● Display automatic or manual mode in operating mode. ● Display setpoint percentage value in operating mode. ● Display function options in menu mode. ● Display initialization step and error sign in initialization process.

Button operation description

Button	Description
	<ul style="list-style-type: none"> ● Enter the system menu. ● Switch automatic and manual mode in operating mode. ● Exit from the system menu to main interface ● Exit from submenu to previous menu.
	<ul style="list-style-type: none"> ● Open or close valve in the initial interface (NOINI). ● Decrease the valve position value in manual mode. If press and hold this button first, then press and hold  button, the valve position value will be reduced quickly. ● Select function options or parameters down and decrease parameter values in menu mode.
	<ul style="list-style-type: none"> ● Open or close valve in the initial interface (NOINI). ● Increase the valve position value in manual mode. If press and hold this button first, then press and hold  button, the valve position value will be increased quickly. ● Select function options or parameters up and increase parameter values in menu mode.
	<ul style="list-style-type: none"> ● Enter submenu, enable or confirm parameter modification in menu mode. ● Run initialization or reset to factory settings. ● Run initialization in initial interface (NOINI) or in operating mode.

8.2. Display and operation of main interface

Positioner is in the uninitialized state before initialization. When LCD displays the sign **NOINI**, interface displays percentage value of sensor in the top line. As shown in Figure 45.

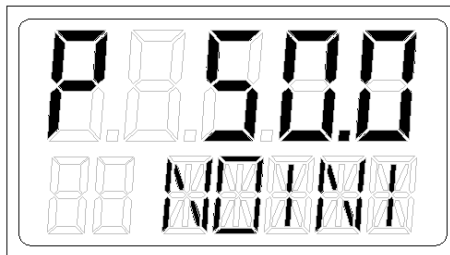



Figure 45. Uninitialized state interface

In this state, pressing  buttons can open and close valve. Open and close valve fully, and observe the percentage value of sensor displayed on the interface. For non-separate type, ensure that within the entire valve stroke range, the minimum sensor percentage value $\geq 5\%$, and the maximum sensor percentage value $\leq 95\%$. Otherwise, it is necessary to re-adjust the installation position to make the linear stroke feedback lever or the angle stroke adapter move within the effective range. For separate type, ensure that within the valve stroke range of 5-25mm, the

minimum sensor percentage value $\geq 12\%$, and the maximum sensor percentage value $\leq 92\%$; within the valve stroke range of 25-50mm, the minimum sensor percentage value $\geq 2\%$, and the maximum sensor percentage value $\leq 97\%$. Otherwise, the D value of the sensor needs to be adjusted. In addition, the minimum and maximum percentage difference of the sensor is required to be greater than 16% (non-separate type) or 8% (separate type).

If you want to take a shortcut of running automatic initialization (INITA), press and hold \square button for approx. 3s to run it in the initial interface (NOINI) or in the operating mode. In the initialization process, pressing \square button will exit. After exiting, if the initialization is completed before, system enters manual mode interface. Otherwise, system enters initial interface (NOINI). After the initialization is completed, press \square button to exit. After exiting, the system enters the manual mode interface.

Operating mode includes automatic mode and manual mode.

In automatic mode, system adjusts the valve position automatically by receiving the effective SP value sent by the master station.

In manual mode, valve position can be adjusted by pressing \square \square buttons manually.

In the main interface, the top line shows the valve position percentage value, and the bottom line shows the set-point percentage value. The last digit of the set-point percentage value is one decimal place. Sign **A** means automatic mode and sign **M** means manual mode. They can be switched by pressing \square button. If the release time after pressing the \square button is less than the operation time of entering the menu, operating mode can be switched. Otherwise, it will enter the menu. As shown in Figure 46.

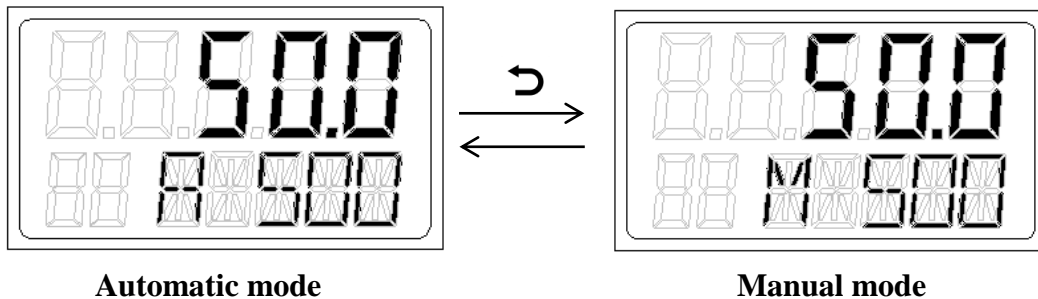

Figure 46. Operating mode interface

In automatic mode, when the safe position function is enabled, the sign **F** is displayed on the interface. If the parameter of the option SAFE is ACT, the set-point value is displayed----. As shown in Figure 47.

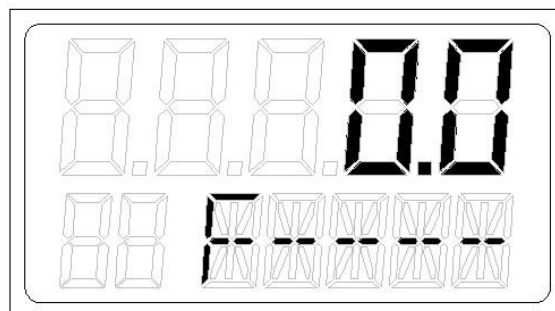



Figure 47. Automatic mode interface for enabling the safe position function

8.3. Menu and functions

8.3.1. Display and operation of menu

Press and hold  button for approx. 3s to enter the menu. The menu interface will display as Figure 48. Press  button, it will exit from menu interface to manual mode interface. The positioner with HART function cannot modify parameters or perform initialization operation through HART communication in the menu interface.

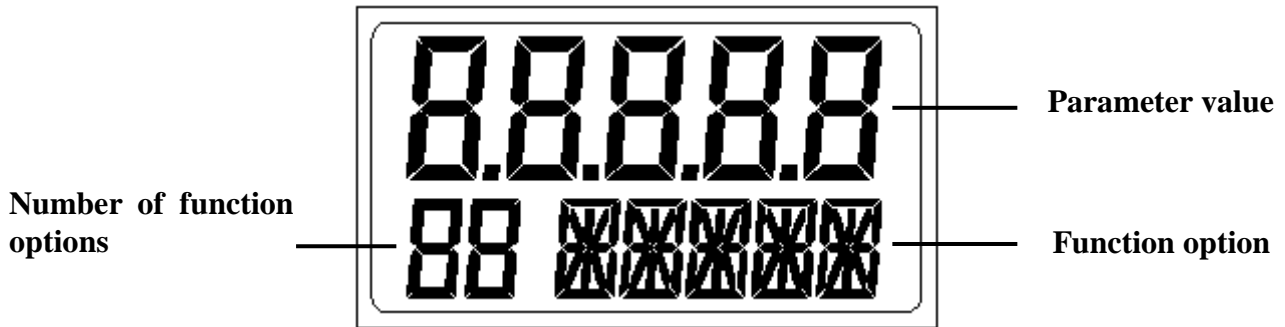

Figure 48. Menu interface





8.3.2. Functions description and operation

8.3.2.1. TYPE

TYPE is for setting the actuator type.

Options for setting parameter

Option	Description
Lin	Linear actuator with feedback lever A installed.
Turn	Rotary actuator.
FLin	Linear actuator with feedback lever B installed.
ELin1	Separate type actuator. Stroke range: 5-25mm.
ELin2	Separate type actuator. Stroke range: 25-50mm.

Select this function in the menu interface, press  button to start setting parameters, and the parameter will flash. Press   buttons to set parameter and press  button to confirm.

8.3.2.2. INITA

The function is auto initialization. It will automatically detect action direction, actual physical stroke of valve and control parameters.

Select this function in the menu interface, press and hold  button for approx. 3s to run, a scroll sign will appear in the lower left corner of LCD. Top line shows the percentage value of sensor and the step is showed in the bottom line. Sign **FINSH** will display on LCD after the auto initialization

is completed.

For some reasons, the system will display an error message in the function option line during the auto initialization process and the auto initialization will be interrupted. Descriptions of error messages and solutions are showed in chapter 8.3.3.

8.3.2.3. INITM

The function is manual initialization. It is suitable for the user to confirm the valve stroke manually. The function requires the user to calibrate the valve stroke manually. Then it will automatically detect action direction and control parameters. The operation flow is as follows:

- 1) Select this function in the menu interface, press and hold button for approx. 3s to run, a scroll sign will appear in the lower left corner of LCD. Top line shows the percentage value of sensor and bottom line shows **END 1**.
- 2) When LCD displays **END 1**, press buttons to let the valve position move to the endpoint 1 of the manual calibrating stroke, and press button to confirm, then LCD will display **END 2**. Next, press buttons again to let the valve position move to the endpoint 2 of the manual calibrating stroke, and press button to confirm.
- 3) If there isn't error message after confirmation of **END 2**, the system will run the step 1 of initialization automatically and skip step 2 for stroke detection.

LCD will display **FINSH** when manual initialization is completed.

For some reasons, the system will display an error message in the function option line during the manual initialization process and the manual initialization will be interrupted. Descriptions of error messages and solutions are showed in chapter 8.3.3.

8.3.2.4. SDIR

This function is used to set the set-point value direction.

Select this function in the menu interface, press button to start setting, and the parameter will flash. Press buttons to set parameter and press button to confirm.

Options for setting parameter

Option	Description
riSE	The larger the SP value sent by the master, the greater the valve opening.
FALL	The larger the SP value sent by the master, the smaller the valve opening.

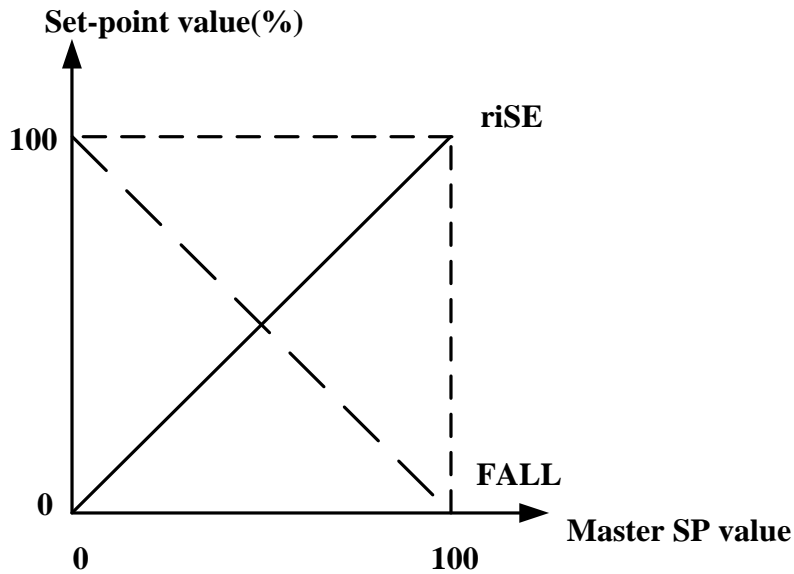

Figure 49. SDIR

8.3.2.5. CHAR

The characteristic curve is the relationship between set-point value and valve stroke.

In the actual control system, it is usually required to make the controlled variable have specific control characteristics (such as linearity). The user can choose and set the corresponding characteristic curve to achieve the control requirements.

The function is to determine the relationship between position set-point value and valve stroke.

Select this function in the menu interface, press button to start setting, and the parameter will flash. Press buttons to set parameter and press button to confirm.

Option for CHAR

Option	Description
Lin	1:1 linear transfer relationship between position set-point value and valve stroke.
1-25	1:25 equal percentage transfer relationship between position set-point value and valve stroke.
1-33	1:33 equal percentage transfer relationship between position set-point value and valve stroke.
1-50	1:50 equal percentage transfer relationship between position set-point value and valve stroke.
n1-25	1:25 inverse equal percentage transfer relationship between position set-point value and valve stroke.
n1-33	1:33 inverse equal percentage transfer relationship between position set-point value and valve stroke.
n1-50	1:50 inverse equal percentage transfer relationship between position set-point value and valve stroke.
FrEE	Freely programmable transfer relationship between position set-point value and valve stroke for user. The position set-point value scale ranging from 0-100% is divided

uniformly into 21 nodes. A freely programmable valve stroke ranging from 0-100% is assigned to each node. User can set value by selecting option **FR 0**, **FR 5**, ..., **FR 100**.

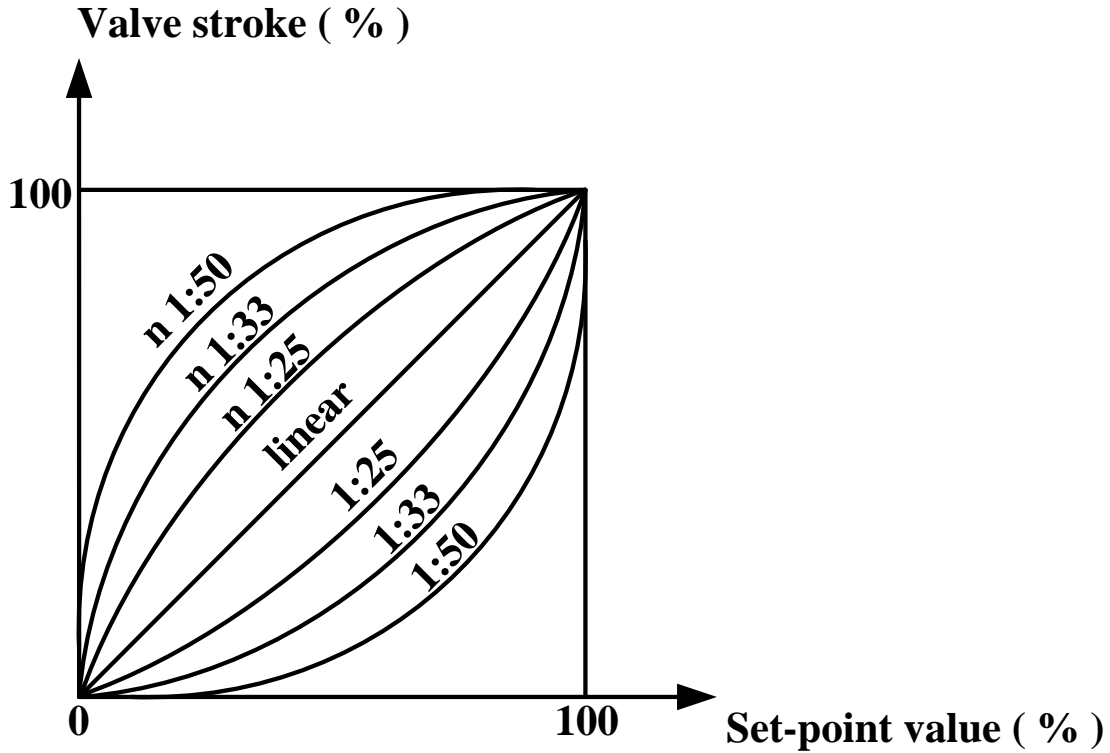

Figure 50. CHAR

8.3.2.6. FREE

Set value of **FrEE** characteristic curve in **CHAR** function option.

Sub-function options of **FREE** are **FR 0**, **FR 5**, ... , **FR 100**, 21 set points in total.

Select this function in the menu interface, press button to enter sub-function option, and select set point by pressing buttons, then press button to start setting parameter, and the parameter will flash. Press buttons to set parameter, it can be modified quickly by pressing or button continuously, finally press button to confirm.

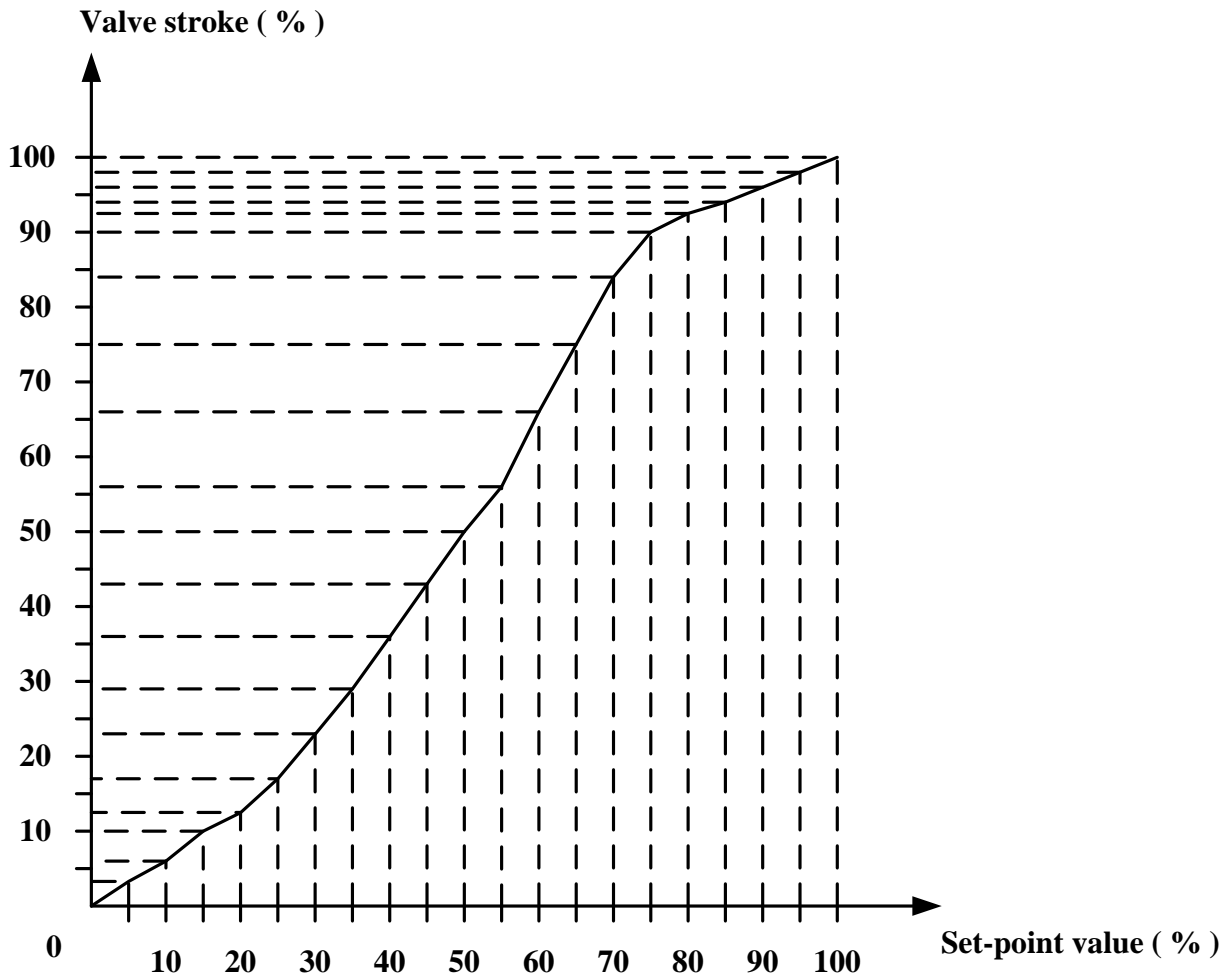

Figure 51. FREE

8.3.2.7. DB

Set Dead band zone of positioner.

The system does not adjust the valve stroke when the gap between the stroke value and the position set-point value is not bigger than the dead band value.

For example, positioner will not do adjustment if the actual valve position is not in the range of $50 \pm 1\%$ when the position set-point value is 50% and dead band value is 1%. If it's not in the range of $50 \pm 1\%$, the piezoelectric module will be driven to adjust valve position until it's in the range of $50 \pm 1\%$.

It's recommended to increase the dead band value if the valve position oscillates. The smaller the dead band sets, the higher control accuracy gets.

Select this function in the menu interface, press button to start setting, and the parameter will flash. Press buttons to set parameter, it can be modified quickly by pressing or button continuously, finally press button to confirm.

8.3.2.8. LIM

This function limits the automatic adjustment range in the whole valve physical stroke.

The LIM sub-function options L MIN and L MAX of set the minimum and maximum limits of the stroke respectively.

Select this function in the menu interface, press button to enter sub-function option, press buttons to select option L MIN or L MAX, press button to start setting, and the parameter will flash. Press buttons to set parameter, it can be modified quickly by pressing or button continuously, finally press button to confirm.

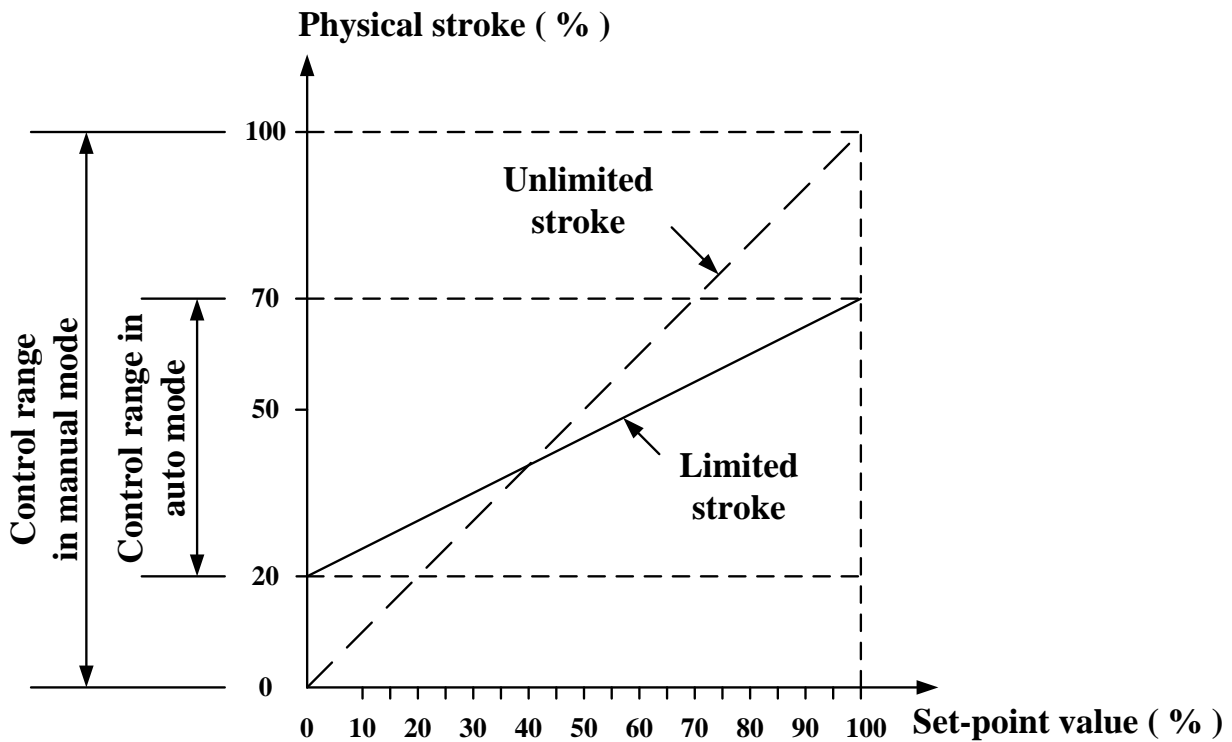

Figure 52. LIM

8.3.2.9. YDIR

This function is used to set the acting direction of the set-point value display and the position value display.

Select this function in the menu interface, press button to start setting, and the parameter will flash. Press buttons to set parameter and press button to confirm.

Options for setting parameter

Option	Description
riSE	The position value and the set-point value are displayed as an uptrend.
FALL	The position value and the set-point value are displayed as a downward trend.

8.3.2.10.CUT

This function is used for the positioner to fully close or open the valve in automatic mode. When the function is enabled, sign **CU** displays in the left bottom in main interface.

The **CUT** sub-function options **C MIN** and **C MAX** respectively set the minimum and maximum values.

Select this function in the menu interface, press \odot button to enter sub-function option, press ∇ \blacktriangle buttons to select option **C MIN** or **C MAX**, press \odot button to start setting, and the parameter will flash. Press ∇ / \blacktriangle buttons to set parameter, it can be modified quickly by pressing ∇ or \blacktriangle button continuously, finally press \odot button to confirm.

When **C MIN** value is 0, full closing is disabled. When **C MAX** value is 100, full opening is disabled.

When valve is in the positioning state, if the set point value \leq **C MIN**, the valve will be fully close; if set point value \geq **C MAX**, it will be fully open.

When the set point value $>$ **C MIN** + 1%, valve will disengage from the full closing state.

When the set point value $<$ **C MAX** - 1%, valve will disengage from the full opening state.

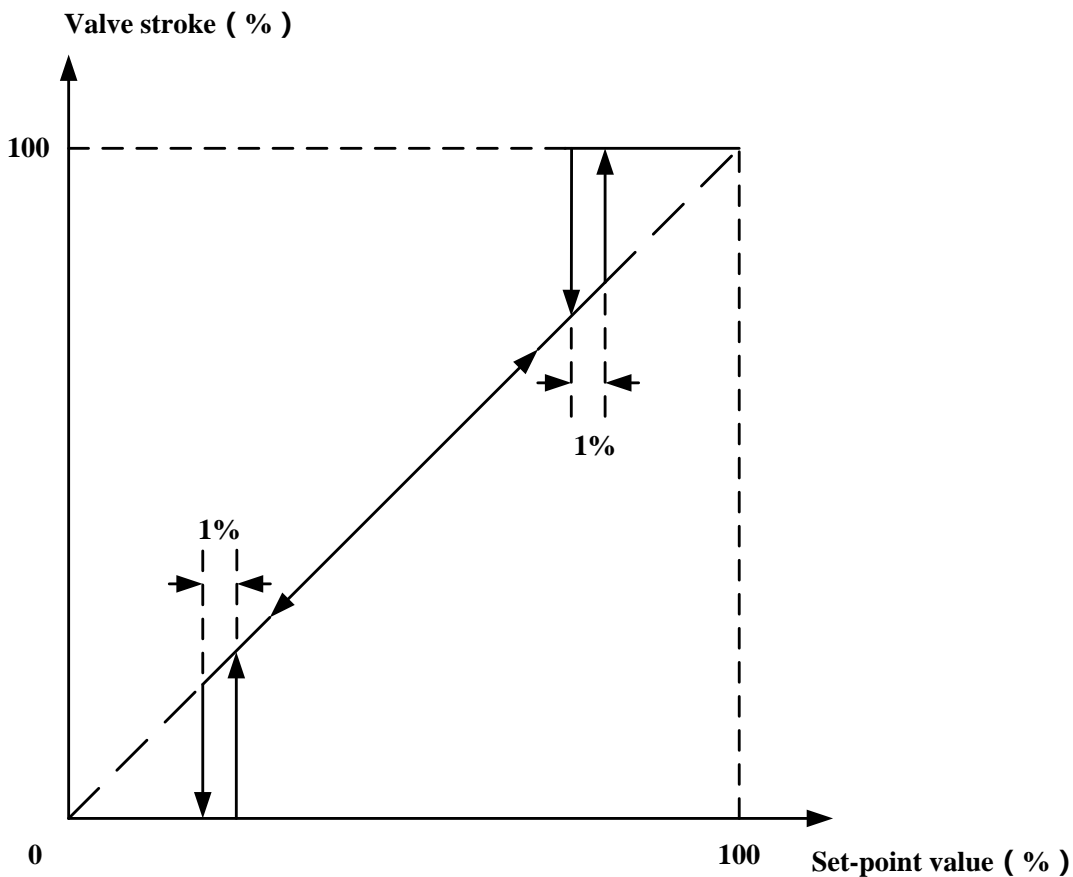

Figure 53. CUT

8.3.2.11.POS

This function is used to set the standard of position display.

Select this function in the menu interface, press \odot button to start setting, and the parameter will

flash. Press buttons to set parameter and press button to confirm.

Options for setting parameter

Option	Description
FS	The position display corresponds to 0-100% of mechanical stroke. The set-point value is displayed as the actual valve position set value. Not affected by the L MIN and L MAX parameters.
LS	The position display takes the form of 0-100% to represent the range between the L MIN and L MAX parameters. The set-point value is displayed with this standard.

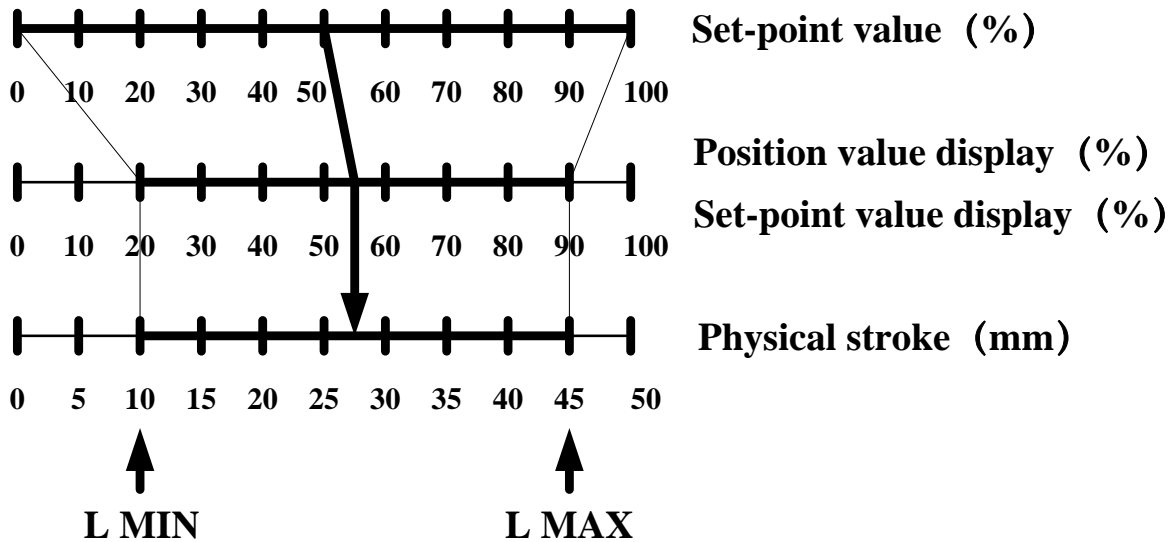

Figure 54. Example: POS = FS, L MIN = 20%, L MAX = 90%

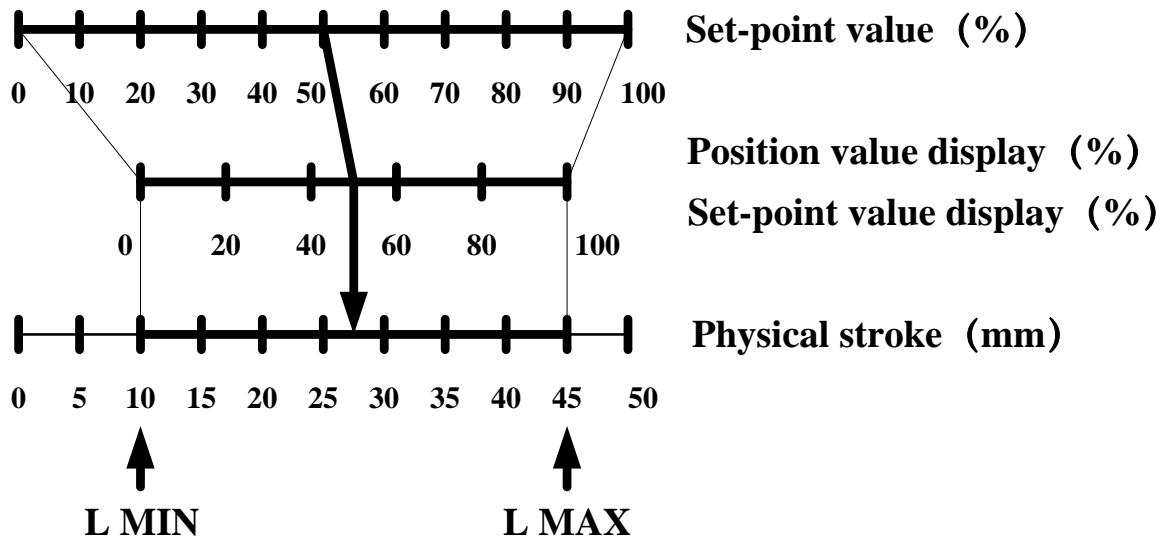

Figure 55. Example: POS = LS, L MIN = 20%, L MAX = 90%

8.3.2.12.SAFE

This function is used in automatic mode to move the valve position to a defined safe position when communication fails or the master sends an error SP status value.

Select this function in the menu interface, press button to start setting, and the parameter will

flash. Press buttons to set parameter and press button to confirm.

Options for setting parameter

Option	Description
ACT	Put the valve position in the position when the positioner is powered off.
LPOS	Use the last valid set-point value to control the valve position.
SPOS	Use the configured safety set-point value to control the valve position.

8.3.2.13.STIM

This function is used to set the waiting time for the valve position to switch to a safe position. The unit is seconds. When the system determines the condition to switch to a safe position, the timer reaches the set waiting time and enables the safe position.

Select this function in the menu interface, press button to start setting, and the parameter will flash. Press buttons to set parameter and press button to confirm.

8.3.2.14.SPOS

This function is used to set the value of the parameter SPOS in the SAFE option.

Select this function in the menu interface, press button to start setting, and the parameter will flash. Press buttons to set parameter and press button to confirm.

8.3.2.15.FACT

Most of the parameters in the menu reset to factory default values.

Select this function in the menu interface, press and hold button for approx. 3s to reset to factory setting. Then the system is in an uninitialized state and the LCD displays **FINSH**.

8.3.2.16.SADDR

This function is used to set the slave address.

Select this function in the menu interface, press button to start setting, and the parameter will flash. Press buttons to set parameter and press button to confirm.

This parameter cannot be changed while the device is conducting normal periodic data communication. This parameter does not reset to the default value after operating the FACT function.

8.3.2.17.WP

This function is a parameter write protection function. The parameter **oFF** is write protection disabled, and the parameter **on** is write protection enabled.

Select this function in the menu interface, press button to start setting, and the parameter will flash. Press buttons to set parameter and press button to confirm.

When the write protection is enabled, menu options 1-16, S/W in option 20, and one-key automatic

initialization are not operational.

8.3.2.18.ACT

This function is used to set acting mode. It is used for the manufacturer. It is not recommended for users to operate this option without special circumstances.

8.3.2.19.REF

Calibrate the reference point of the linear feedback lever. It is used for the manufacturer. It is not recommended for users to operate this option without special circumstances.



8.3.2.20.REC

Record the running data of the positioner.

Options for data recording

Option	Description
HOURS	Running hours count. Start recording after the positioner are powered on.
P CNT	Positive deviation count. In automatic mode, when the positioner is in position control, the position value corresponding to the initialized mechanical stroke is compared with the position set-point value. If the set-point value is greater than the position value, and the deviation between the two exceeds the dead zone value + 10% and lasts for more than 1 minute, the cumulative count is carried out once.
N CNT	Negative deviation count. In automatic mode, when the positioner is in position control, the position value corresponding to the initialized mechanical stroke is compared with the position set-point value. If the position value is greater than the set-point value, and the deviation between the two exceeds the dead zone value + 10% and lasts for more than 1 minute, the cumulative count is carried out once.
CLR	Clear the HOURS, P CNT, N CNT records. Select this option in the submenu of REC, press and hold  button for approx. 3s to run the function. Then the records are cleared and the LCD displays FINSH .
S/W	Enable or disable the data recording. The parameter oFF is disabled, and the parameter on is enabled.

8.3.3. Error message during initialization

Sign	Meaning	Possible reasons	Solutions
ERR 1	Actuator action error	<ul style="list-style-type: none"> No air pressure or insufficient air pressure There is a leakage from actuator or positioner. 	<ul style="list-style-type: none"> Check air source and its pressure to make sure that it meets the requirement Eliminate air leakage
ERR 2	<p>For non-separate type positioner, rotation angle of actuator feedback lever or rotating shaft is error.</p> <p>For separate type positioner, valve stroke does not meet requirements.</p>	<ul style="list-style-type: none"> The non-separate type positioner is not installed correctly. As a result, the rotation angle of actuator feedback lever or rotating shaft doesn't meet the installation requirements. When running the manual initialization, the difference from END 1 to END 2 doesn't meet the installation requirements. 	<ul style="list-style-type: none"> For the non-separate type positioner, in the initial interface (NOINI), adjust the installation position by the angle sensor percentage value displayed on LCD, make sure the minimum and maximum percentage difference of the angle sensor rotation is greater than 16%. If it's in the manual initialization operation process, press   buttons to re-calibrate END 1 and END 2, make sure that difference percentage value between two endpoints of sensor is bigger than 16% (non-separate type) or 8% (separate type).
ERR 3	error minimum stroke value of sensor	The positioner is not installed correctly.	For the non-separate type positioner, in the initial interface (NOINI), adjust the installation position by the sensor percentage value displayed on LCD. Make sure that minimum percentage value of sensor $\geq 5\%$. For the separate type positioner, readjust the D value. Make sure that minimum percentage value of sensor $\geq 12\%$ (ELin1) or 2% (ELin2).
ERR 4	Error maximum stroke value of sensor	The positioner is not installed correctly.	For the non-separate type positioner, In the initial interface (NOINI), adjust the installation position by the sensor

			percentage value displayed on LCD. Make sure that maximum percentage value of sensor \leq 95%. For the separate type positioner, readjust the D value. Make sure that maximum percentage value of sensor \leq 92%(ELin1) or 97%(ELin2).
--	--	--	---

8.3.4. Tips of menu option or function cannot access

When setting menu option parameters or running initialization, the following signs may appear to indicate that they cannot be accessed. See the table below for specific instructions.

Sign	Meaning
P1	Write protection is enabled.
P2	The reference point of the linear feedback lever is not calibrated, and the initialization operation of the linear actuator cannot be performed.

8.3.5. Menu function options summary description

Options	Functions	Parameter value	Factory settings
1 TYPE	Actuator type setting	Lin Turn FLin ELin1 ELin2	Lin
2 INITA	Auto initialization		
3 INITM	Manual initialization		
4 SDIR	Set the direction of set-point value	riSE FALL	riSE
5 CHAR	Select characteristic curve	Lin 1:25 1:33 1:50 n1:25 n1:33 n1:50 FrEE	Lin
6 FREE→FR 0, FR 5...FR 100	Custom parameters settings	0.0% – 100.0%	0.0% 5.0% etc. to 100.0%
7 DB	Set dead band	0.2 – 10.0%	1.0%
8 LIM→L MIN	Set minimum value for stroke range limit function	0.0% – 100.0%	0.0%
8 LIM→L MAX	Set maximum value for	0.0% – 100.0%	100.0%

	stroke range limit function		
9 YDIR	Set the acting direction of position display and set-point display	riSE FALL	riSE
10 CUT→C MIN	Set minimum value for tight cut function	0.0% – 100.0%	1.0%
10 CUT→C MAX	Set maximum value for tight cut function	0.0% – 100.0%	100.0%
11 POS	Set position display standard	FS LS	FS
12 SAFE	Safe position setting	ACT LPOS SPOS	ACT
13 STIM	Waiting time setting for safe position	0-100s	0s
14 SPOS	Safe position set-point value	0.0% – 100.0%	0.0%
15 FACT	Reset to factory setting		
16 SADDR	Slave address setting	0-126	126
17 WP	Write protection	oFF on	oFF
18 ACT	Acting mode selection		
19 REF	Calibrate the reference point of the linear feedback lever		
20 REC→HOURS	Running hours count	0-876000	0
20 REC→P CNT	Positive deviation count	0-99999	0
20 REC→N CNT	Negative deviation count	0-99999	0
20 REC→CLR	Clear data recording		
20 REC→S/W	Enable or disable the data recording	oFF on	on

8.4. PROFIBUS PA functions and operation

8.4.1. Slave address setting

In order to implement periodic data transmission and non-periodic data transmission between the control system(master) and the positioner (slave), the slave address of the positioner needs to be set first. The slave address can be set in the device menu option or via the bus using SIMATIC PDM V6.0 software. The slave address is factory set to 126.

8.4.2. Periodic data transmission

Periodic data transmission is used to transfer parameters related to process automation between the Type 1 master and the positioner.

8.4.2.1. Configuration

Import the GSD file provided by the vendor into the Siemens STEP7 software. Create a project on STEP7 and use the configuration tool **HW config** to configure the device.

8.4.2.2. Data definition

Name	Transmission direction (for positioner)	Number of bytes	Description
SP	Input	5 (value/status)	The set-point value, which consists of a 4-byte floating point value and a 1-byte status.
READBACK	Output	5 (value/status)	The feedback value, which consists of a 4-byte floating point value and a 1-byte status. The value corresponds to the valve position value or sensor value displayed on the positioner screen.
POS_D	Output	2 (value/status)	Discrete valve position value , which consists of a 1-byte value and a 1-byte status.
CHECKBACK	Output	3 (value)	Indicates some of the operating status of the positioner in a bit-encoded format.

POS_D

Value	Meaning
0	Not initialized.
1	The valve is closed. Position value $\leq 1\%$.
2	The valve is open. Position value $\geq 99\%$.
3	The valve is in the middle position. $1\% < \text{Position value} < 99\%$.

CHECKBACK

Byte	Bit	Definition of "1"
------	-----	-------------------

0	0	The positioner is in the fail-safe position.
	1	Reserved.
	2	Configure the parameters in the menu or run one-key automatic initialization.
	3	In the manual mode or uninitialized interface (NOINI).
	4~7	Reserved.
1	0	The positioner is performing the action of opening the valve.
	1	The positioner is performing the action of closing the valve.
	2	If modify the parameters in function options 1, 4~14 or run function option 15 in the menu, it will be temporarily set after exiting from the menu.
	3~7	Reserved.
2	0~7	Reserved.

8.4.2.3. Data combination

The periodic data transmission between the master and the positioner includes the following four data combinations, and user can choose the appropriate data combination form according to the actual needs.

Combination 1: SP

Output (master)		
Start address	0	SP floating-point
	1	
	2	
	3	
	4	SP status

Combination 2: READBACK + POS_D, SP

Input (master)		
Start address	0	READBACK floating-point
	1	
	2	
	3	
	4	READBACK status
	5	POS_D
	6	POS_D status

Output (master)		
Start address	0	SP floating-point
	1	
	2	

	3	
	4	SP status

Combination 3: CHECKBACK, SP

Input (master)		
Start address	0	CHECKBACK
	1	
	2	

Output (master)		
Start address	0	SP floating-point
	1	
	2	
	3	
	4	SP status

Combination 4: READBACK + POS_D + CHECKBACK, SP (default)

Input (master)		
Start address	0	READBACK floating-point
	1	
	2	
	3	
	4	
	5	POS_D
	6	POS_D status
	7	CHECKBACK
	8	
	9	

Output (master)		
Start address	0	SP floating-point
	1	
	2	
	3	
	4	SP status

8.4.3. Non-periodic data transmission

The non-periodic data transmission is mainly used for data transmission between the Type 2 master and the positioner during field test and maintenance. The master and the positioner carry out non-periodic data transmission via SIMATIC PDM V6.0.

8.4.3.1. SIMATIC PDM V6.0 operation steps

1. Use the **Manage device catalog** tool in SIMATIC PDM V6.0 to import the EDD file of the device.
2. Open the **LifeList** tool in SIMATIC PDM V6.0. When the device is scanned, double-click the device in the device bar and the following interface is displayed:

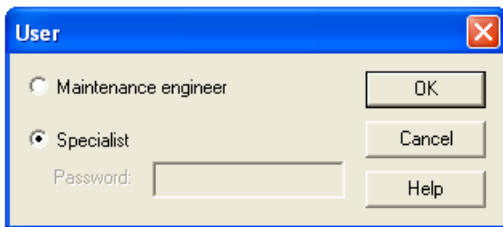

Select the option **Specialist**, and click **OK**.

3. The PDM operation interface is opened. As shown below.

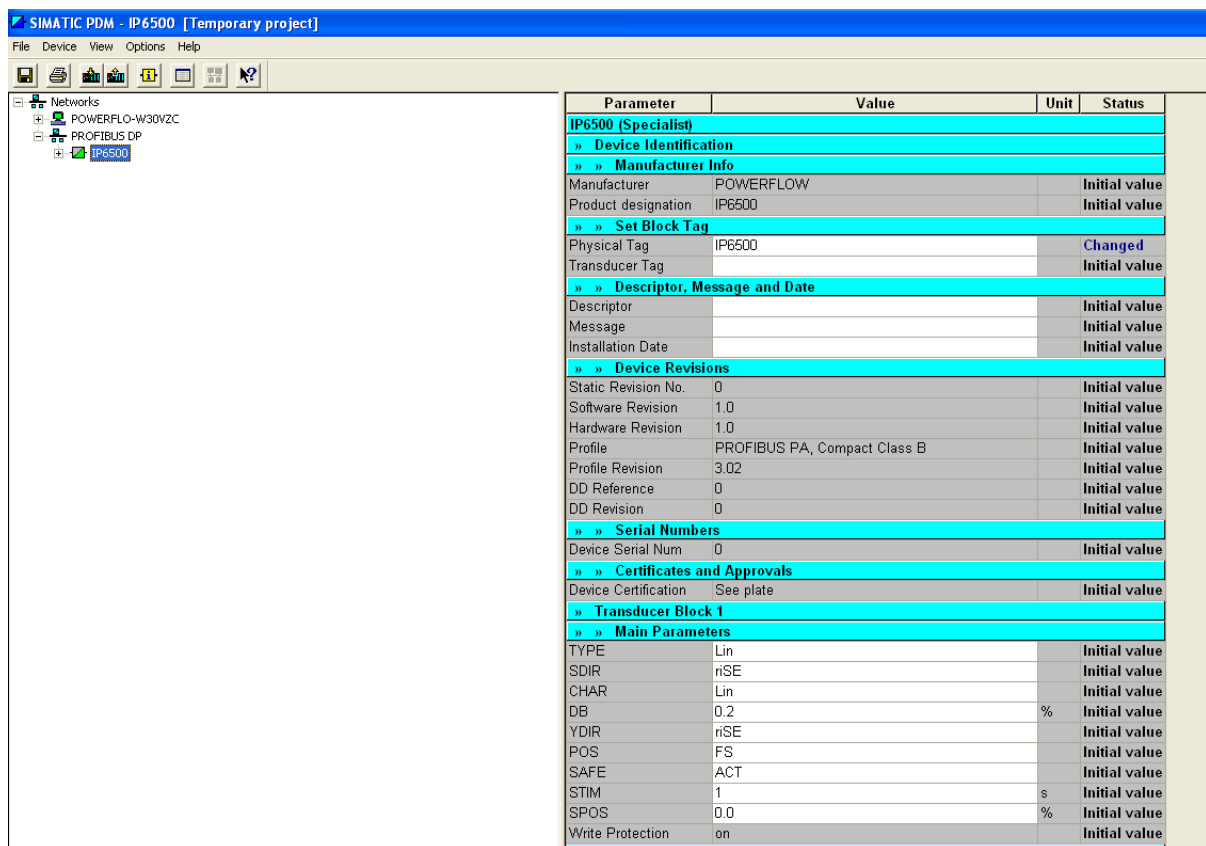

4. Click  button to upload the data. The parameter bar on the right side of the interface displays the read device-related parameters. The displayed parameters correspond to most of

the device menu parameters.

5. Modify the parameters in the parameter bar on the right side of the interface. After the modification, click  button to download the modified data to the device.

NOTE:

- **When using SIMATIC PDM V6.0 for data transmission, please don't operate the positioner locally, and the display interface of the positioner should not stay in the menu interface. If the parameters are downloaded during running the initialization function or in the menu interface, the positioner will not update the download parameters until exiting initialization function or exiting from the menu interface for a period of time.**
- **Must finishing data upload operation before modifying and downloading parameters.**

8.4.3.2. Slave address setting via SIMATIC PDM V6.0

Select the option **Set Address** to set the slave address in the PDM "Device" menu. If the slave address is modified, it is need to close the PDM operation interface and use LifeList to scan the connected device again.

8.4.3.3. FACT and CLR functions via SIMATIC PDM V6.0

The FACT and CLR options in PDM "Device" menu correspond to the FACT and CLR options in the positioner menu. They are used separately to reset the positioner to factory settings and clear data records of option REC. If necessary, select the relevant option to perform the corresponding function.

8.5. Adjust air flow

1. Remove the circuit board protective cover.

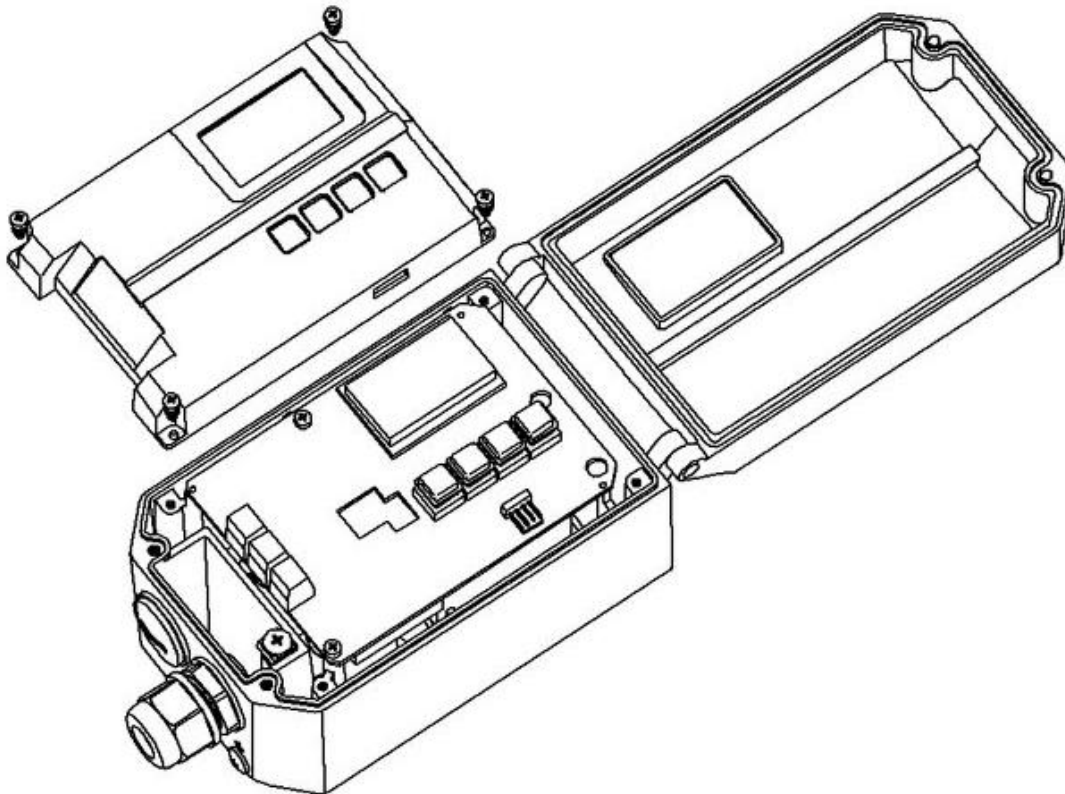

Figure 56. Remove the circuit board protective cover

NOTE : Must install or remove the circuit board protective cover when the device is powered off.

2. Adjust restrictors

- Restrictors Y1① and Y2② can reduce air output to increase the stability of positioning for small volume actuators.
- Turning the Restrictors in clockwise direction with a flat blade screwdriver can reduce the air flow until it is cut off.
- When adjusting restrictors, it is recommended to close them first and then open them again slowly.
- Make sure two restrictors are turned to the similar position for the double-acting actuator.

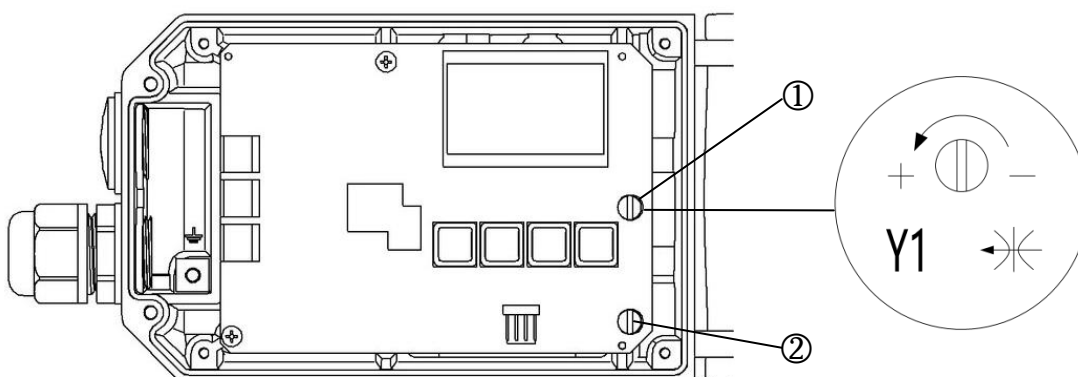

Figure 57. Air flow adjustment

- ① Restrictors Y1
- ② Restrictors Y2 , only for double-acting actuator.

9. Trouble shooting

Contents	Possible reasons	Solutions
LCD has no display.	Error electrical connections.	Check the electrical connections.
	Power failure.	Check whether the power supply is normal.
	Use a power supply that is out of specification.	Use a power supply that meets the specification range.
	Others.	Consult with manufacturer.
LCD displays the sign F .	Communication failure.	Check whether the slave address is correct.
	The master sends an incorrect SP status value.	Set the SP status value to 0x80.
There is no air output in OUT1 or OUT2 (Without any action) .	The air supply pressure is abnormal.	Check the setting of the air pressure reducing valve.
	Accessory pipe leakage.	Check the pipe and connection to make sure that there isn't any leakage.
	Others.	Consult with manufacturer.
Bad accuracy (Linear and hysteresis phenomena).	The air supply pressure changes.	Check whether there is any abnormality of the air supply pressure reducing valve.
	The mounting bolts loose.	Make sure the mounting bolts are tightened.
	The connection place between the positioner and the actuator has gap.	Check the connection.
	Others.	Consult with manufacturer.

10. Warranty terms

1. If the product is found to have quality problems which are confirmed by our company staff, customers have after-sale services for product maintenance or free replacement in the warranty period. Service response time is 24 hours (excluding non-working days).

2. The warranty period of the product is based on the company's latest warranty policy, which is no less than 12 months after the sale.
3. The following situations for repaired product do not belong to the warranty range:
 - (1) The date is not in the warranty period.
 - (2) The product is disassembled without authorization and permit by the product company.
 - (3) The damage causes from the operation which is not according to the product instruction manual or other human factors. Including but not limited to:
 - 1> The product surface has collision scars.
 - 2> Error wiring or error power supply makes the product damaged.
 - 3> Parts and accessories are lost.
 - 4> The product is damaged due to the oil entering the product without oil separator or filter pressure reducer being installed.
 - 5> Error using the waterproof electrical connectors makes the product damaged.
 - (4) Force majeure (natural disasters) causes product failure or damage.
4. According to the actual situation, the product company offers the free or fee-based maintenance services outside the warranty range.
5. The terms become effective since the two sides signed a supply contract.

V250314

本说明书内容变更，恕不另行通知。

相关技术更新本公司保留最终解释权。

The changed contents of this manual are not noticed.

The Company reserves the final interpretation for related technical updating

附件

智能阀门定位器气源要求

全系列产品

按照技术要求，全系列的智能阀门定位器气源要求为 3 级，提供符合气源要求的压缩空气，可以确保定位器的正常使用。

露点 3 级：露点为 -20°C 。（若定位器实际工作环境温度低于 -20°C ，则使用的压缩空气露点需相应低于定位器实际工作环境温度 -10°C ）

固体颗粒大小和密度 3 级： $5.0\text{mg}/\text{m}^3$ （对应粒径为 $5.0\mu\text{m}$ ），不允许有粒径大于 $5.0\mu\text{m}$ 的颗粒进入。

含油量 3 级： $1.0\text{mg}/\text{m}^3$ ，每单位立方米的空气累积油含量不超过 1.0mg 。

流程示例



图1. 流程图

①在主管路中配备压缩空气干燥机，过滤掉压缩空气中产生的大部分水分，过滤后的压力露点可达到 -20°C ；

②选择任意与图 2 一致的调压过滤器组合安装在定位器管路的前端，安装时需过滤减压阀（空气过滤器）在前，油雾分离器在后，要求过滤器过滤粒径在 $5.0\mu\text{m}$ 以上的颗粒，最高残余油含量 $\leq 1.0\text{mg}/\text{m}^3$ 。

过滤减压阀 + 油雾分离器

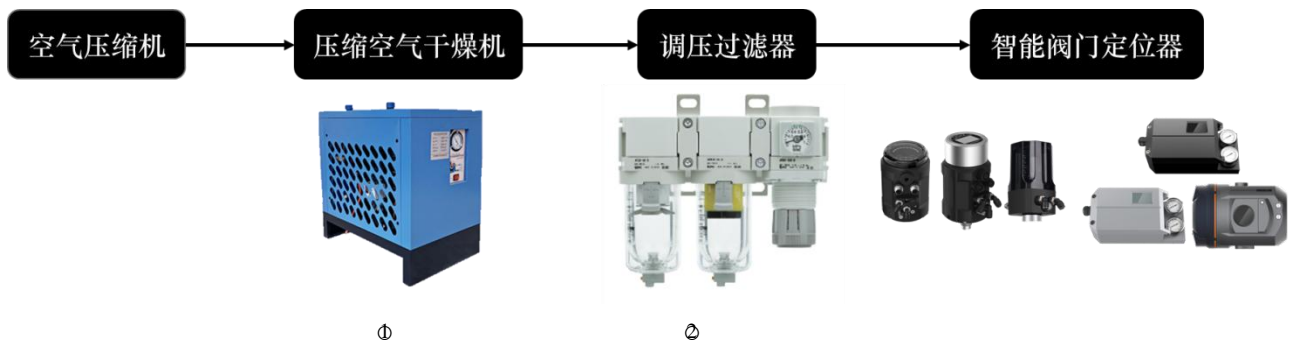
AW

AFM



AC20D-A~AC40D-A 系列

空气过滤器 + 油雾分离器 + 减压阀

AF

AFM

AR



AC20C-A~AC40C-A 系列

图2. 调压过滤器组合

过滤器选型推荐

选型组合	<p>空气过滤器 + 油雾分离器 + 减压阀</p> <p>AF AFM AR</p>	<p>过滤减压阀 + 油雾分离器</p> <p>AW AFM</p>
	<p>AC 30 C- 03 DG- - -A</p> <p style="text-align: center;"> 1 2 3 4 5 6 </p>	<p>AC 30 D- 03 DG- - -A</p> <p style="text-align: center;"> 1 2 3 4 5 6 </p>
选型编号	SMC AC20C-02G-A	SMC AC20D-02G-A
	入口侧压缩空气质量略低于定位器使用要求时	入口侧压缩空气质量符合定位器使用要求时
基础参数	流体：空气	

	环境温度及使用温度：-5~60℃（未冻结） 耐压：1.5MPa 使用压力范围：0.05~1.0MPa 设定压力范围：0.05~0.7MPa 过滤精度：AW:5um、AFM: 0.3um（捕集效率 99.9%） 杯体材质：聚碳酸酯 结构：溢流型		
选型参数	①主体尺寸：20 额定流量：200L/min 杯体保护罩：标准（钢带） 质量：0.39kg ②螺纹种类（无记号）：Rc ③接口管径 O2：1/4 ④无记号：手动排水器 压力表 G：圆形压力表（带限位指示器） ⑤无记号：无附件 ⑥无记号：无特殊选择	①主体尺寸：20 额定流量： 150L/min 杯体保护罩：标准 （钢带） 质量：0.33kg	①主体尺寸：30 额定流量： 330L/min 杯体保护罩：标准 装备（聚碳酸酯） 质量：0.66kg
		②螺纹种类（无记号）：Rc ③接口管径 O2：1/4 ④无记号：手动排水器 压力表 G：圆形压力表（带限位指示器） ⑤无记号：无附件 ⑥无记号：无特殊选择	
1 系列定位器*	●	●	/
IP 系列定位器*	●	/	●

*●为推荐的选择

注：过滤器处理空气额定流量需大于定位器的最大工作流量，在同一串联管路上存在多台定位器时则最大工作流量需相加计算（1 系列最大流量 1500、1600：Q1-17L/min；Q2-95L/min；1880S: 17L/min IP 系列最大流量 IP5500: 155 L/min；IP6000/IP6500:187 L/min；IP6000d: 150 L/min 以上数据均为 0.6MPa 下测量所得）。

注意事项

1. 应视工况要求选择不同性能的调压过滤器，避免因工作环境的高温、低温、高压、腐蚀等原因导致调压过滤器失效,详见末尾附录选型表。
2. 定期巡查过滤器的使用情况，若使用频繁的工况应提高巡查次数，避免因过滤器滤芯堵塞导致的故障问题（故障举例：①过滤失效，导致定位器进入异物，致使定位器故障；②滤芯堵塞，导致气源供应异常，定位器无法正常工作等）。
3. 采用自动排水功能的调压过滤器需要避免排水孔的堵塞，定期巡查可避免过滤器故障导致滤杯内大量积水。手动排水的应视工况下过滤器的积水速率，定时人工排水。
4. 按照调压过滤器的使用说明，定期维护或更换不合格的产品，可避免不必要的故障出现。